

# CHAMPION

GLOBAL POWER EQUIPMENT™

OWNER'S MANUAL & OPERATING INSTRUCTIONS



4000 Starting Watts / 3500 Rated Watts  
Recoil Start

# PORTABLE GENERATOR



MODEL NUMBER  
**46597**

**SAVE THESE INSTRUCTIONS**  
Important Safety Instructions  
are included in this manual.

MADE IN CHINA  
REV 46597-20120606

10006 Santa Fe Springs Road  
Santa Fe Springs CA 90670  
USA / 1-877-338-0999  
[www.championpowerequipment.com](http://www.championpowerequipment.com)

**Have questions or need assistance?**

*Do not return this product to the store!*

**WE ARE HERE TO HELP!**

Visit our website:

**[www.championpowerequipment.com](http://www.championpowerequipment.com)**

for more info:

- Product Info & Updates
- Tech Bulletins
- Frequently Asked Questions
- Product Registration

– or –

Call our Customer Care Team Toll-Free at:

**1-877-338-0999**

**WARNING:**

The Engine Exhaust from this product contains chemicals known to the State of California to cause cancer, birth defects or other reproductive harm.

\*We are always working to improve our products. Therefore, the enclosed product may differ slightly from the image on the cover.

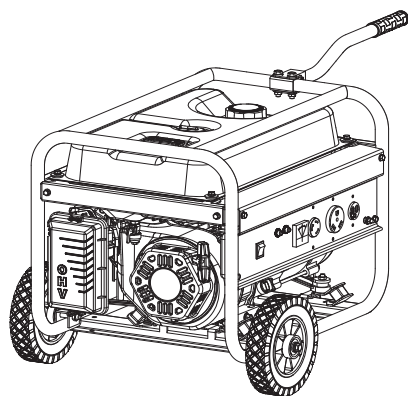

4000 Starting Watts / 3500 Rated Watts  
Recoil Start

# PORTABLE GENERATOR

## TABLE OF CONTENTS

<b>Introduction</b> . . . . .	<b>1</b>	Spark Arrester . . . . .	15
Introduction . . . . .	1	In-line Fuel Filter . . . . .	15
Portable Power Generator . . . . .	1	Cleaning . . . . .	15
Accessories . . . . .	1	Adjustments . . . . .	15
This Booklet . . . . .	1	Maintenance Schedule . . . . .	15
<b>Manual Conventions</b> . . . . .	<b>2</b>	Generator Maintenance . . . . .	16
<b>Safety Rules</b> . . . . .	<b>3</b>	Storage . . . . .	16
<b>Controls and Features</b> . . . . .	<b>5</b>	Generator Storage . . . . .	16
Generator . . . . .	5	<b>Specifications</b> . . . . .	<b>17</b>
Power Panel . . . . .	6	Engine Specifications . . . . .	17
Parts Included . . . . .	7	Generator Specifications . . . . .	17
Wheel Kit . . . . .	7	Fuel . . . . .	17
Spark Arrester Kit . . . . .	7	Oil . . . . .	17
Other . . . . .	7	Spark Plugs . . . . .	17
<b>Assembly</b> . . . . .	<b>8</b>	Valve Clearance . . . . .	17
Remove the Generator from the Shipping Carton . . . . .	8	Wiring Diagram . . . . .	18
Install the Wheel Kit . . . . .	8	Parts Diagram . . . . .	19
Install the Support Leg . . . . .	8	Parts List . . . . .	20
Install the Handle . . . . .	8	Engine Parts Diagram . . . . .	21
Install the Spark Arrester . . . . .	9	Engine Parts List . . . . .	22
Add Engine Oil . . . . .	9	<b>Troubleshooting</b> . . . . .	<b>23</b>
Add Fuel . . . . .	10	<b>Warranty</b> . . . . .	<b>24</b>
Grounding . . . . .	10	Warranty Qualifications . . . . .	24
<b>Operation</b> . . . . .	<b>11</b>	Repair/Replacement Warranty . . . . .	24
Generator Location . . . . .	11	Do Not Return The Unit To	
Grounding . . . . .	11	The Place Of Purchase . . . . .	24
Surge Protection . . . . .	11	Warranty Exclusions . . . . .	24
Starting the Engine . . . . .	11	Normal Wear . . . . .	24
Connecting Electrical Loads . . . . .	12	Installation, Use and Maintenance . . . . .	24
Stopping the Engine . . . . .	12	Other Exclusions . . . . .	24
Do Not Overload Generator . . . . .	12	Limits of Implied Warranty	
Capacity . . . . .	12	and Consequential Damage . . . . .	24
Power Management . . . . .	12	Contact Information . . . . .	24
Operation at High Altitude . . . . .	13	Address . . . . .	24
<b>Maintenance and Storage</b> . . . . .	<b>14</b>	Customer Service . . . . .	24
Engine Maintenance . . . . .	14	Technical Service . . . . .	24
Oil . . . . .	14		
Spark Plugs . . . . .	14		
Air Filter . . . . .	14		

# INTRODUCTION

## Introduction

Congratulations on your purchase of a Champion Power Equipment generator. CPE designs and builds generators to strict specifications. With proper use and maintenance, this generator will bring years of satisfying service.

## Portable Power Generator

This unit is a gasoline engine driven, alternating current (AC) generator. It is designed to supply electrical power for lighting, appliances, tools and similar equipment.

## Accessories

Champion Power Equipment manufactures and sells accessories designed to help you get the most from your purchase. To find out more about our covers, power cables and storm kits, please visit our web site at:  
→ [www.championpowerequipment.com](http://www.championpowerequipment.com)

## This Booklet

Every effort has been made to ensure the accuracy and completeness of the information in this manual. We reserve the right to change, alter and/or improve the product and this document at any time without prior notice.

Record the model and serial numbers as well as date and place of purchase for future reference. Have this information available when ordering parts and when making technical or warranty inquiries.

Champion Power Equipment Support	
1-877-338-0999	
Model Number	
46597	
Serial Number	
Date of Purchase	
Purchase Location	
For <b>Oil Type</b> see 'Add Engine Oil' section. For <b>Fuel Type</b> see 'Add Fuel' section.	

This manual uses the following symbols to help differentiate between different kinds of information. The safety symbol is used with a key word to alert you to potential hazards in operating and owning power equipment.

Follow all safety messages to avoid or reduce the risk of serious injury or death.

 **DANGER**

DANGER indicates an imminently hazardous situation which, if not avoided, **will** result in death or serious injury.

 **WARNING**

WARNING indicates a potentially hazardous situation which, if not avoided, **could** result in death or serious injury.

 **CAUTION**

CAUTION indicates a potentially hazardous situation which, if not avoided, **may** result in minor or moderate injury.

**CAUTION**

CAUTION used without the safety alert symbol indicates a potentially hazardous situation which, if not avoided, **may** result in property damage.

 **NOTE**

If you have questions regarding your generator, we can help. Please call our help line at **1-877-338-0999**.

# SAFETY RULES

## WARNING

Read this manual thoroughly before operating your generator. Failure to follow instructions could result in serious injury or death.

## WARNING

The engine exhaust from this product contains chemicals known to the state of California to cause cancer, birth defects, or other reproductive harm.

## DANGER

Generator exhaust contains carbon monoxide, a colorless, odorless, poison gas. Breathing carbon monoxide will cause nausea, dizziness, fainting or death. If you start to feel dizzy or weak, get to fresh air immediately.

Operate generator outdoors only in a well ventilated area.

DO NOT operate the generator inside any building, including garages, basements, crawlspaces and sheds, enclosure or compartment, including the generator compartment of a recreational vehicle. DO NOT allow exhaust fumes to enter a confined area through windows, doors, vents or other openings.

**DANGER CARBON MONOXIDE:** using a generator indoors **CAN KILL YOU IN MINUTES.**

## DANGER

Rotating parts can entangle hands, feet, hair, clothing and/or accessories.  
Traumatic amputation or severe laceration can result.

Keep hands and feet away from rotating parts.  
Tie up long hair and remove jewelry.  
Operate equipment with guards in place.  
DO NOT wear loose-fitting clothing, dangling drawstrings or items that could become caught.

## DANGER

Generator produces powerful voltage.

DO NOT touch bare wires or receptacles.  
DO NOT use electrical cords that are worn, damaged or frayed.  
DO NOT operate generator in wet weather.  
DO NOT allow children or unqualified persons to operate or service the generator  
Use a ground fault circuit interrupter (GFCI) in damp areas and areas containing conductive material such as metal decking.  
Use approved transfer equipment to isolate generator from your electric utility and Notify your utility company before connecting your generator to your power system.

## WARNING

Sparks can result in fire or electrical shock.

### When servicing the generator:

Disconnect the spark plug wire and place it where it cannot contact the plug.  
DO NOT check for spark with the plug removed.  
Use only approved spark plug testers.

## WARNING

Running engines produce heat. Severe burns can occur on contact.  
Combustible material can catch fire on contact.

DO NOT touch hot surfaces.  
Avoid contact with hot exhaust gases.  
Allow equipment to cool before touching.  
Maintain at least three feet of clearance on all sides to ensure adequate cooling.  
Maintain at least five feet of clearance from combustible materials.

## WARNING

Medical and Life Support Uses.

In case of emergency, call 911 immediately.  
NEVER use this product to power life support devices or life support appliances.  
NEVER use this product to power medical devices or medical appliances.  
Inform your electricity provider immediately if you or anyone in your household depends on electrical equipment to live.  
Inform your electrical provider immediately if a loss of power would cause you or anyone in your household to experience a medical emergency.

**⚠ DANGER**

Fuel and fuel vapors are highly flammable and extremely explosive.  
Fire or explosion can cause severe burns or death.  
Unintentional startup can result in entanglement, traumatic amputation or laceration.

**When adding or removing fuel:**

Turn the generator off and let it cool for at least two minutes before removing the fuel cap. Loosen the cap slowly to relieve pressure in the tank.  
Only fill or drain fuel outdoors in a well-ventilated area. DO NOT pump gas directly into the generator at the gas station. Use an approved container to transfer the fuel to the generator.  
DO NOT overfill the fuel tank.  
Always keep fuel away from sparks, open flames, pilot lights, heat and other sources of ignition.  
DO NOT light or smoke cigarettes.

**When starting the generator:**

DO NOT attempt to start a damaged generator.  
Make certain that the gas cap, air filter, spark plug, fuel lines and exhaust system are properly in place.  
Allow spilled fuel to evaporate fully before attempting to start the engine.  
Make certain that the generator is resting firmly on level ground.

**When operating the generator:**

DO NOT move or tip the generator during operation.  
DO NOT tip the generator or allow fuel or oil to spill.

**When transporting or servicing the generator:**

Make certain that the fuel shutoff valve is in the off position and the fuel tank is empty.  
Disconnect the spark plug wire.  
When storing the generator:  
Store away from sparks, open flames, pilot lights, heat and other sources of ignition.

**⚠ WARNING**

Operation of this equipment may create sparks that can start fires around dry vegetation.

A spark arrestor may be required. The operator should contact local fire agencies for laws or regulations relating to fire prevention requirements.

**⚠ WARNING**

Rapid retraction of the starter cord will pull hand and arm towards the engine faster than you can let go.  
Unintentional startup can result in entanglement, traumatic amputation or laceration.  
Broken bones, fractures, bruises or sprains could result.

When starting engine, pull the starter cord slowly until resistance is felt and then pull rapidly to avoid kickback.  
DO NOT start or stop the engine with electrical devices plugged in.

**⚠ CAUTION**

Exceeding the generator's running capacity can damage the generator and/or electrical devices connected to it.

DO NOT overload the generator.  
Start the generator and allow the engine to stabilize before connecting electrical loads.  
Connect electrical equipment in the off position, and then turn them on for operation.  
Turn electrical equipment off and disconnect before stopping the generator.  
DO NOT tamper with the governed speed.  
DO NOT modify the generator in any way.

**⚠ CAUTION**

Improper treatment or use of the generator can damage it, shorten its life and void your warranty.

Use the generator only for intended uses.  
Operate only on level surfaces.  
DO NOT expose generator to excessive moisture, dust, or dirt.  
DO NOT allow any material to block the cooling slots.  
If connected devices overheat, turn them off and disconnect them from the generator.  
DO NOT use the generator if:

- Electrical output is lost
- Equipment sparks, smokes or emits flames
- Equipment vibrates excessively

# CONTROLS AND FEATURES

Read this owner's manual before operating your generator. Familiarize yourself with the location and function of the controls and features. Save this manual for future reference.

## Generator

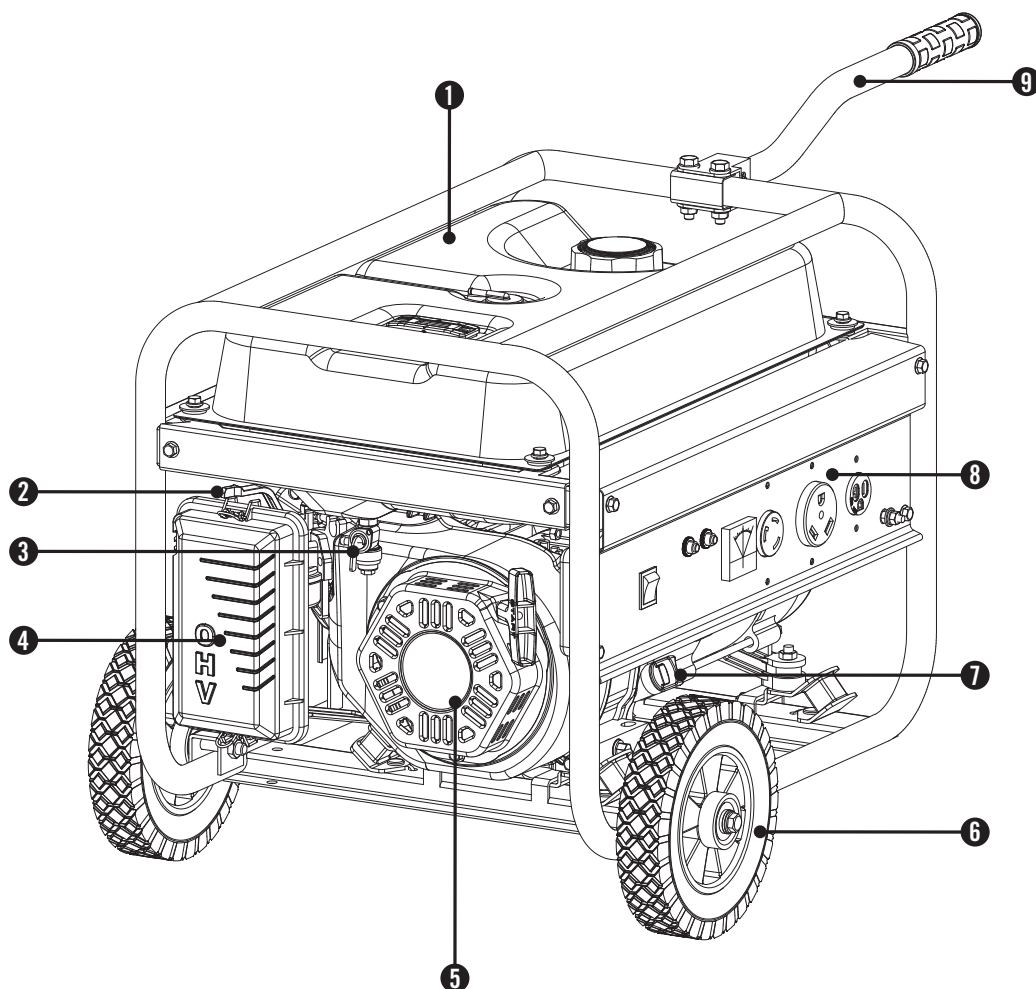

- |   |  |
|---|--|
| (1) <b>Fuel Tank</b> – 3.8 gal. (14.4 L) capacity fuel tank.                                  | (6) <b>Never Flat Tires</b>                                  |
| (2) <b>Choke</b> – Used to start the engine.  | (7) <b>Oil Filler Cap</b> – Check and fill engine oil level. |
| (3) <b>Fuel Valve</b> – Used to turn fuel supply on and off to engine.                        | (8) <b>Power Panel</b> – See “Power Panel” section.          |
| (4) <b>Air Filter</b> – Protects the engine by filtering dust and debris from the intake air. | (9) <b>Handle</b>  |
| (5) <b>Recoil Starter</b> – Used to manually start the engine.                                |  |



## Power Panel

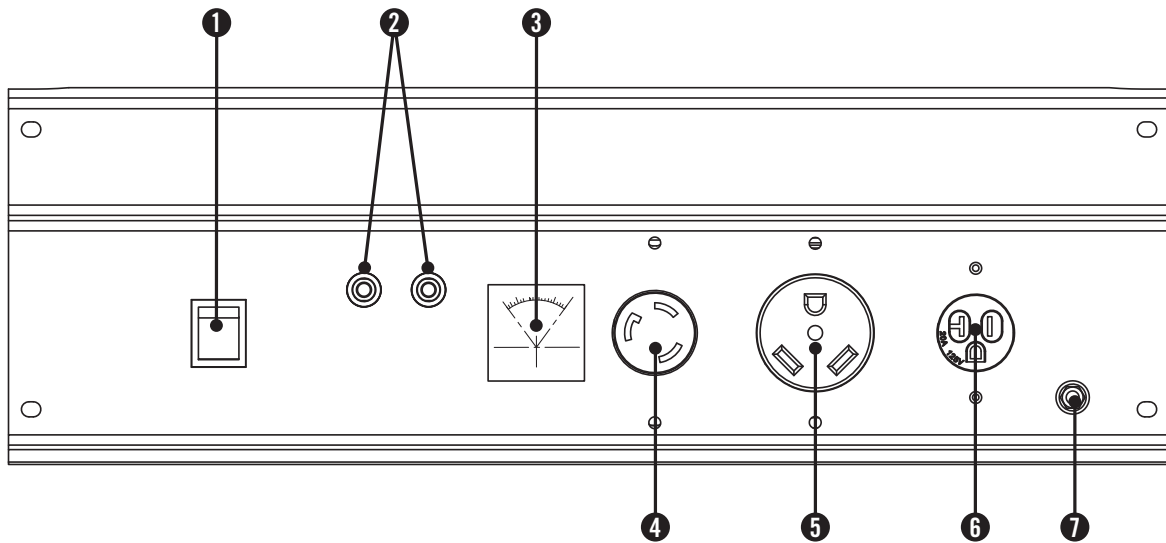

- (1) **Engine Switch** – Used to start or stop the generator.
- (2) **Circuit Breakers** – Protects the generator against electrical overloads.
- (3) **Voltmeter** – Used to display alternator output voltage.
- (4) **120 Volt AC, 30 Amp Twist-Lock Receptacle (NEMA L5-30R)** – May be used to supply electrical power for the operation of 120 Volt AC, 30 Amp, single phase 60 Hz electrical loads.
- (5) **120 Volt AC, 30 Amp Receptacle (TT-30R)** – May be used to supply electrical power for the operation of 120 Volt AC, 30 Amp, single phase 60 Hz electrical loads.
- (6) **120 Volt AC, 20 Amp Receptacle (NEMA 5-20R)** – May be used to supply electrical power for the operation of 120 Volt AC, 20 Amp, single phase 60 Hz electrical loads.
- (7) **Ground Terminal** – Consult an electrician for local grounding regulations.

# CONTROLS AND FEATURES

## Parts Included

Your 46597 Gasoline Powered Generator ships with the following parts:

### Wheel Kit

- 8" Wheel . . . . . 2
- Flange Bolt (M10x105 for Wheel) . . . . . 2
- Bushing . . . . . 2
- Flat Washer 10mm . . . . . 2
- Nut (M10) . . . . . 2
- Flange Bolt (M8x25 for Vibration Mounts) . . . . . 2
- Flange Bolt (M8x16 for Support Leg) . . . . . 2
- Handle . . . . . 1
- Flange Bolt (M8x45 for Handle) . . . . . 2
- Nut (M8) . . . . . 6

### Spark Arrester Kit

- Spark Arrester . . . . . 1
- Cover Plate . . . . . 1
- Screw with Lock Washer . . . . . 2

### Other

- Oil Funnel . . . . . 1
- Spark Plug Socket . . . . . 1

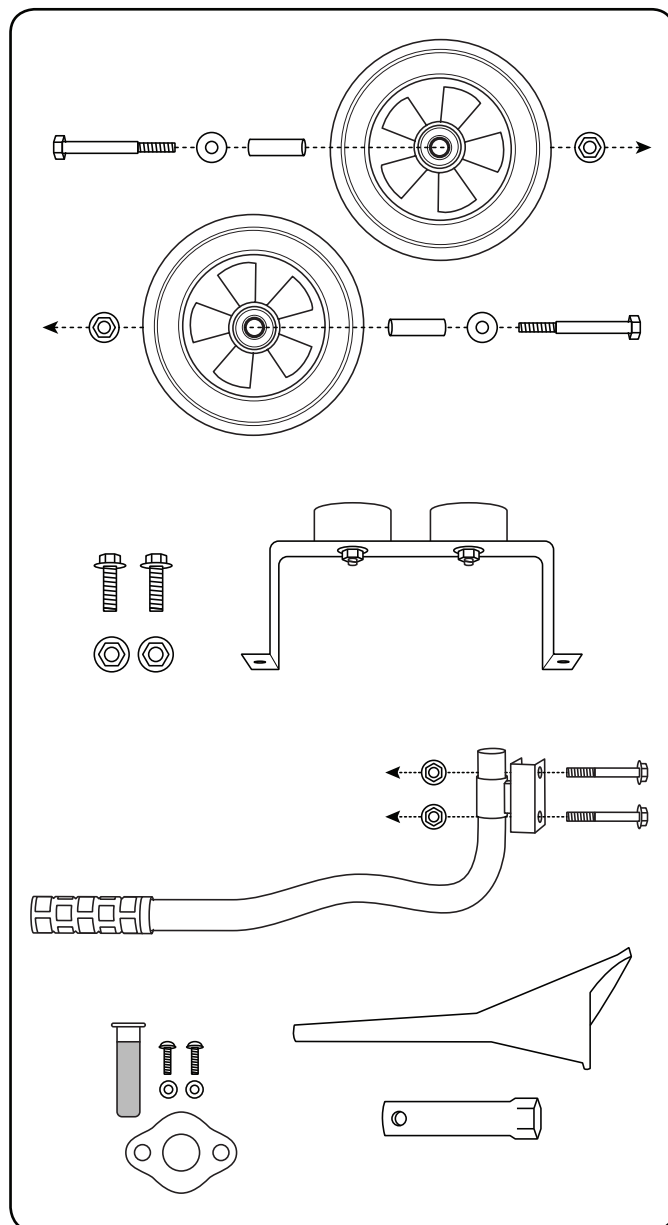

Your generator requires some assembly. This unit ships from our factory without oil. It must be properly serviced with fuel and oil before operation.

If you have any questions regarding the assembly of your generator, call our help line at 1-877-338-0999. Please have your serial number and model number available.

### Remove the Generator from the Shipping Carton

1. Set the shipping carton on a solid, flat surface.
2. Remove everything from the carton except the generator.
3. Carefully cut each corner of the box from top to bottom. Fold each side flat on the ground to provide a surface area to install the wheel kit and support leg.

### Install the Wheel Kit

#### ! CAUTION

The wheel kit is not intended for over-the-road use.

You will need the following tools to install the wheels:

- 17 mm wrench OR adjustable wrench (not included)
- Socket wrench with a 16 mm socket (not included)
- Pliers (not included)

1. Before adding fuel and oil, tip the generator on it's side.
2. Slide the M10x105 wheel bolt through the washer, sleeve and wheel.
3. Slide the bolt through the mount point on the frame.
4. Fasten securely with the M10 nut.
5. Repeat steps 2-4 to attach the second wheel.

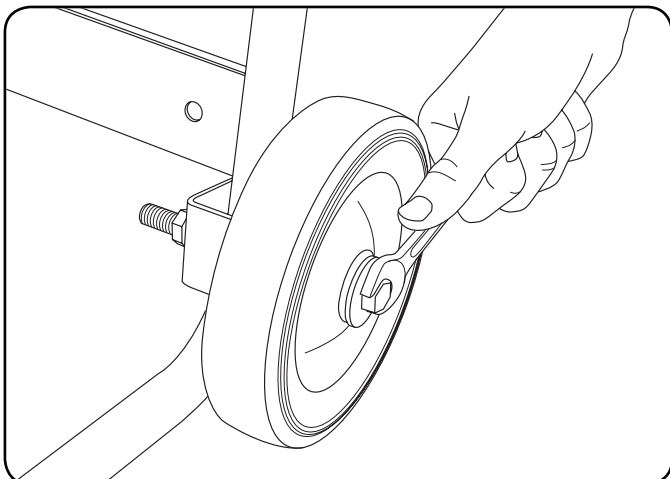

### Install the Support Leg

1. Attach the support leg to the generator frame with cap screws (M8x16) and nuts (M8).
2. Tip the generator slowly so that it rests on the wheels and support leg.

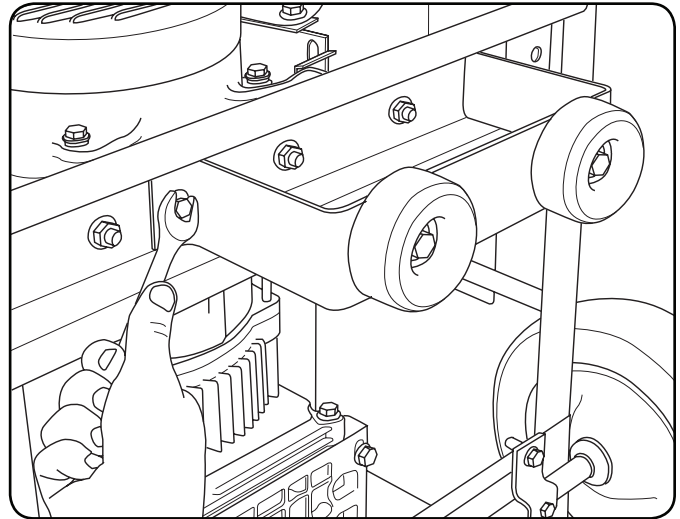

### Install the Handle

1. Place the handle over the mounting channel on the frame.
2. Secure the handle to the frame using the two handle bolts (M8x45).
3. Place a lock nut (M8) on the end of each bolt and fasten securely. DO NOT over tighten the lock nuts.

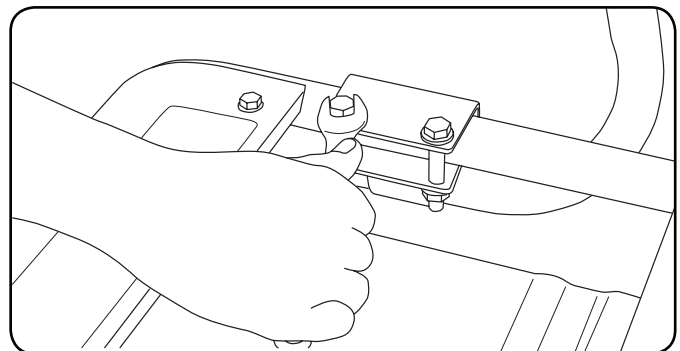

# ASSEMBLY

## Install the Spark Arrester

1. Insert the spark arrester screen into the muffler outlet.
2. Secure the spark arrester by placing the cover plate over the end of the screen, with the lettering facing outward.

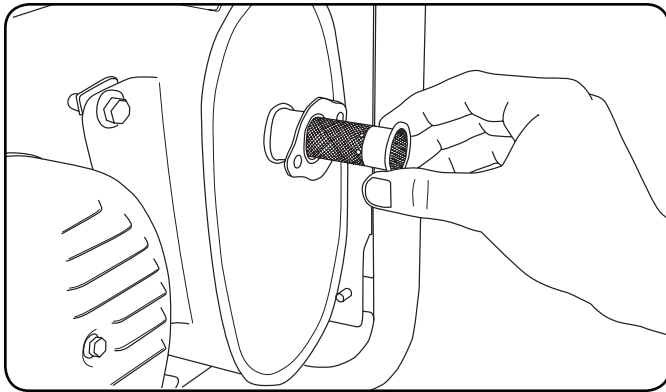

3. Secure the cover plate with the two screws and lock washers provided with the spark arrester kit.

### NOTE

Federal and local laws and administrative requirements indicate when and where spark arresters are required. When ordered, spark arresters are required for operation of this generator in National Forest lands. In California, this generator must not be used on any forest-covered land, brush-covered land, or grass-covered land unless the engine is equipped with a spark arrester.

### CAUTION

Failure to install the spark arrester may result in an increased risk of fire.

## Add Engine Oil

### CAUTION

DO NOT attempt to crank or start the engine before it has been properly filled with the recommended type and amount of oil. Damage to the generator as a result of failure to follow these instructions will void your warranty.

### NOTE

The recommended oil type is 10W-30 4-cycle automotive oil.

## Add Engine Oil Cont'd.

1. Place the generator on a flat, level surface.

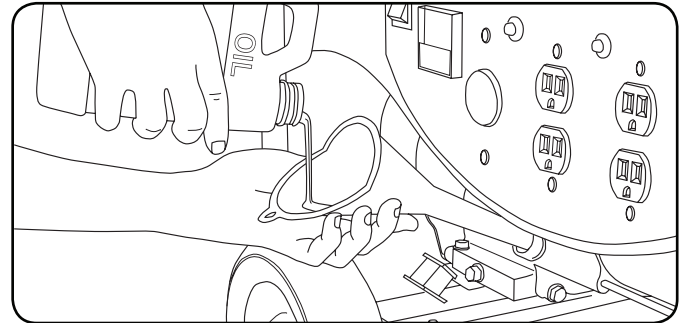

2. Remove oil fill cap/dipstick to add oil.
3. Add up to 0.63 qt. (0.6 L) of oil and replace oil fill cap/dipstick.

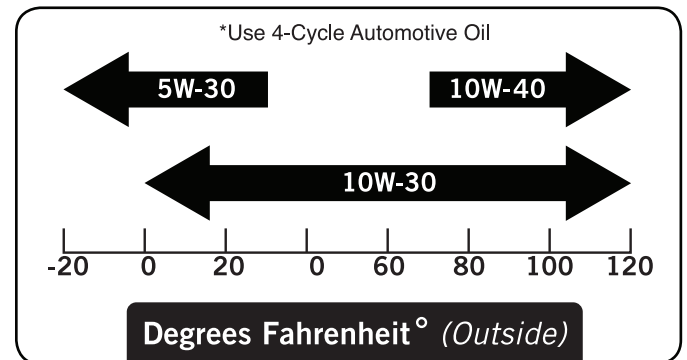

4. Check engine oil level daily and add as needed.

### CAUTION

The engine is equipped with a low-oil-shutoff and will stop when the oil level in the crankcase falls below the threshold level.

### NOTE

Check oil often during the break-in period. Refer to the Maintenance section for recommended service intervals.

### NOTE

The generator rotor has a sealed, pre-lubricated ball bearing that requires no additional lubrication for the life of the bearing.

## Add Fuel

1. Use clean, fresh, regular unleaded fuel with a minimum octane rating of 85 and an ethanol content of less than 10% by volume.
2. DO NOT mix oil with fuel.
3. Clean the area around the fuel cap.
4. Remove the fuel cap.
5. Slowly add fuel to the tank. DO NOT overfill. Allow approximately ¼ inch of space for fuel expansion.

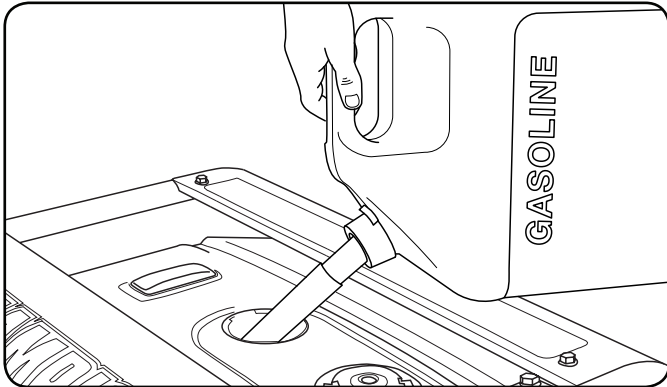

6. Screw on the fuel cap and wipe away any spilled fuel.

### ⚠ CAUTION

Use regular unleaded gasoline with a minimum octane rating of 85.

Do not mix oil and gasoline.  
 Fill tank to approximately ¼" below the top of the tank to allow for fuel expansion.  
 DO NOT pump gas directly into the generator at the gas station. Use an approved container to transfer the fuel to the generator.  
 DO NOT fill fuel tank indoors.  
 DO NOT fill fuel tank when the engine is running or hot.  
 DO NOT overfill the fuel tank.  
 DO NOT light cigarettes or smoke when filling the fuel tank.

### ⚠ WARNING

Pouring fuel too fast through the fuel screen may result in blow back of fuel at the operator while filling.

## Add Fuel Cont'd.

### NOTE

Our engines work well with 10% or less ethanol blend fuels. When using blended fuels there are some issues worth noting:

- Ethanol-gasoline blends can absorb more water than gasoline alone.
- These blends can eventually separate, leaving water or a watery goo in the tank, fuel valve and carburetor.
- With gravity-fed fuel supplies, this compromised fuel can be drawn into the carburetor and cause damage to the engine and/or potential hazards.
- There are only a few suppliers of fuel stabilizer that are formulated to work with ethanol blend fuels.
- Any damages or hazards caused by using improper fuel, improperly stored fuel, and/or improperly formulated stabilizers, are not covered by manufacture's warranty.

It is advisable to always shut off the fuel supply, run the engine to fuel starvation and drain the tank when the equipment is not in use for more than 30 days.

## Grounding

Your generator must be properly connected to an appropriate ground to help prevent electric shock.

### ⚠ WARNING

Failure to properly ground the generator can result in electric shock.

A ground terminal connected to the frame of the generator has been provided on the power panel. For remote grounding, connect a length of heavy gauge (12 AWG minimum) copper wire between the generator ground terminal and a copper rod driven into the ground. We strongly recommend that you consult with a qualified electrician to ensure compliance with local electrical codes.

# OPERATION

## Generator Location

Please consult your local authority. In some areas, generators must be registered with the local utility. Generators used at construction sites may be subject to additional rules and regulations.

This generator must have at least five feet of clearance from combustible material. Leave at least three feet of clearance on all sides of the generator to allow for adequate cooling, maintenance and servicing.

Place the generator in a well-ventilated area. DO NOT place the generator near vents or intakes where exhaust fumes could be drawn into occupied or confined spaces. Carefully consider wind and air currents when positioning generator.

### WARNING

Do not operate or store the generator in rain, snow, or wet weather.

Using a generator or electrical appliance in wet conditions, such as rain or snow, or near a pool or sprinkler system, or when your hands are wet, could result in electrocution.

## Grounding

The generator system ground connects the frame to the ground terminals on the power panel.

- The generator (stator winding) is isolated from the frame and from the AC receptacle ground pin.
- Electrical devices that require a grounded receptacle pin connection may not function properly.

## Surge Protection

### CAUTION

Voltage fluctuation may impair the proper functioning of sensitive electronic equipment.

Electronic devices, including computers and many programmable appliances use components that are designed to operate within a narrow voltage range and may be affected by momentary voltage fluctuations. While there is no way to prevent voltage fluctuations, you can take steps to protect sensitive electronic equipment.

1. *Install UL1449, CSA-listed, plug-in surge suppressors on the outlets feeding your sensitive equipment.*  
Surge suppressors come in single- or multi-outlet styles. They're designed to protect against virtually all short-duration voltage fluctuations.

## Starting the Engine

1. Make certain the generator is on a flat, level surface.
2. Disconnect all electrical loads from the generator.  
Never start or stop the generator with electrical devices plugged in or turned on.
3. Turn the Fuel Valve to the "ON" position.
4. Flip the ignition switch to the "ON" position.
5. Move the choke lever to the "CHOKE" position.
6. Pull the starter cord slowly until resistance is felt and then pull rapidly
7. Do not over-choke. As soon as engine starts, move the choke lever to the "RUN" position.

### NOTE

Keep choke lever in "Choke" position for only 1 pull of the recoil starter. After first pull, move choke lever to the "Run" position for up to the next 3 pulls of the recoil starter. Too much choke leads to spark plug fouling/engine flooding due to the lack of incoming air. This will cause the engine not to start.

### NOTE

If the engine starts but does not run make certain that the generator is on a flat, level surface. The engine is equipped with a low oil sensor that will prevent the engine from running when the oil level falls below a critical threshold.

## Connecting Electrical Loads

1. Let the engine stabilize and warm up for a few minutes after starting
2. Plug in and turn on the desired 120 Volt AC single phase, 60 Hz electrical loads.
  - DO NOT connect 3-phase loads to the generator.
  - DO NOT connect 50 Hz loads to the generator.
  - DO NOT overload the generator.

### NOTE

Connecting a generator to your electric utility company's power lines or to another power source may be against the law. In addition this action, if done incorrectly, could damage your generator and appliances and could cause serious injury or even death to you or a utility worker who may be working on nearby power lines. If you plan to run a portable electric generator during an outage, please notify your electric utility company immediately and remember to plug your appliances directly into the generator. Do not plug the generator into any electric outlet in your home. Doing so could create a connection to the utility company power lines. You are responsible for ensuring that your generator's electricity does not feed back into the electric utility power lines.

If the generator will be connected to a building electrical system, consult your local utility company or a qualified electrician. Connections must isolate generator power from utility power and must comply with all applicable laws and codes.

## Stopping the Engine

1. Turn off and unplug all electrical loads. Never start or stop the generator with electrical devices plugged in or turned on.
2. Let the generator run at no-load for several minutes to stabilize internal temperatures of the engine and generator.
3. Turn the Fuel Valve to the "OFF" position.
4. Let the engine run until fuel starvation has stopped the engine. This usually takes a few minutes.
5. Press the ignition switch to the "OFF" position.

**Important:** Always ensure that the Fuel Valve and the Engine Switch are in the "OFF" position when the engine is not in use.

### NOTE

If the engine will not be used for a period of two (2) weeks or longer, please see the Storage section for proper engine and fuel storage.

## Do Not Overload Generator

### Capacity

Follow these simple steps to calculate the running and starting watts necessary for your purposes.

1. Select the electrical devices you plan on running at the same time.
2. Total the running watts of these items. This is the amount of power you need to keep your items running.
3. Identify the highest starting wattage of all devices identified in step 1. Add this number to the number calculated in step 2. Surge wattage is the extra burst of power needed to start some electric driven equipment. Following the steps listed under "Power Management" will guarantee that only one device will be starting at a time.

### Power Management

Use the following formula to convert voltage and amperage to watts:

$$\text{Volts} \times \text{Amps} = \text{Watts}$$

To prolong the life of your generator and attached devices, follow these steps to add electrical load:

1. Start the generator with no electrical load attached
2. Allow the engine to run for several minutes to stabilize.
3. Plug in and turn on the first item. It is best to attach the item with the largest load first.
4. Allow the engine to stabilize.
5. Plug in and turn on the next item.
6. Allow the engine to stabilize.
7. Repeat steps 5-6 for each additional item.

### NOTE

Never exceed the specified capacity when adding loads to the generator.

# OPERATION

## Operation at High Altitude

The density of air at high altitude is lower than at sea level. Engine power is reduced as the air mass and air-fuel ratio decrease. Engine power and generator output will be reduced approximately 3½% for every 1000 feet of elevation above sea level. This is a natural trend and cannot be changed by adjusting the engine. At high altitudes increased exhaust emissions can also result due to the increased enrichment of the air fuel ratio. Other high altitude issues can include hard starting, increased fuel consumption and spark plug fouling. To alleviate high altitude issues other than the natural power loss, Champion Power Equipment can provide a high altitude carburetor main jet. The alternative main jet and installation instructions can be obtained by contacting Customer Support. Installation instructions are also available in the Technical Bulletin area of the Champion Power Equipment internet site. The part number and recommended minimum altitude for the application of the high altitude carburetor main jet is listed in the table below.

In order to select the correct high altitude main jet it is necessary to identify the carburetor model. For this purpose, a code is stamped on the side of the carburetor. Select the correct main jet part number corresponding to the carburetor code found on your particular carburetor.

Carburetor Code	Main Jet	Part Number	Altitude
P19-2-Z	Standard	ST168FD-2-1131000-17Z	<b>6000 Feet (1800 Meters)</b>
	Altitude	ST168F-2-1131000-17Z	
P19-2-H	Standard	ST168FD-2-1131000-17H	
	Altitude	ST168F-2-1131000-17H	

### WARNING

Operation using the alternative main jet at elevations lower than the recommended minimum altitude can damage the engine. For operation at lower elevations, the standard main jet must be used. Operating the engine with the wrong engine configuration at a given altitude may increase its emissions and decrease fuel efficiency and performance.



The owner/operator is responsible for all periodic maintenance.

### **WARNING**

Never operate a damaged or defective generator.

### **WARNING**

Tampering with the factory set governor will void your warranty.

### **WARNING**

Improper maintenance will void your warranty.

### **NOTE**

Maintenance, replacement, or repair of emission control devices and systems may be performed by any non-road engine repair establishment or individual.

Complete all scheduled maintenance in a timely manner. Correct any issue before operating the generator.

### **NOTE**

For service or parts assistance, contact our help line at **1-877-338-0999**

## Engine Maintenance

To prevent accidental starting, remove and ground spark plug wire before performing any service.

### Oil

Change oil when the engine is warm. Refer to the oil specification to select the proper grade of oil for your operating environment.

1. Remove the oil drain plug with a 12 mm socket and extension.
2. Allow the oil to drain completely.
3. Replace the drain plug.
4. Remove oil fill cap/dipstick to add oil.
5. Add up to 0.63 qt. (0.6 L) of oil and replace oil fill cap/dipstick.
6. Dispose of used oil at an approved waste management facility.

### Oil Cont'd.

#### **NOTE**

Once oil has been added, a visual check should show oil about 1-2 threads from running out of the fill hole. If using the dipstick to check oil level, **DO NOT** screw in the dipstick while checking.

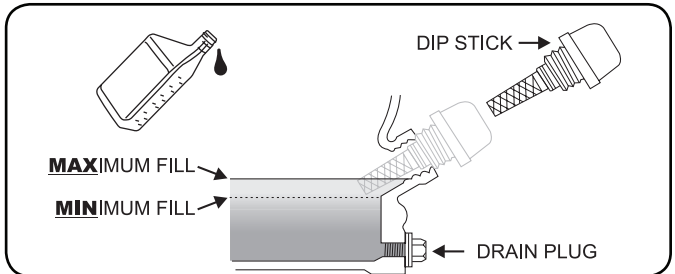

### Spark Plugs

1. Remove the spark plug cable from the spark plug.
2. Use a 13/16" or 21 mm socket to remove the plug.
3. Inspect the electrode on the plug. It must be clean and not worn to produce the spark required for ignition.
4. Make certain the spark plug gap is 0.7 - 0.8mm or (0.028 - 0.031 in.).

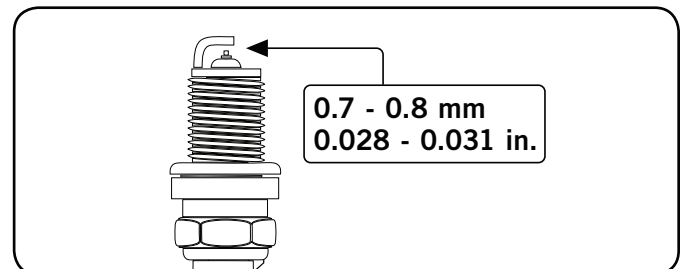

5. Refer to the spark plug recommendation chart when replacing the plug.
6. Carefully thread the plug into the engine.
7. Use the spark plug tool to firmly install the plug.
8. Attach the spark plug wire to the plug.

### Air Filter

1. Remove the snap-on cover holding the air filter to the assembly.
2. Remove the foam element.
3. Wash in liquid detergent and water. Squeeze thoroughly dry in a clean cloth.
4. Saturate in clean engine oil.
5. Squeeze in a clean, absorbent cloth to remove all excess oil.
6. Place the filter in the assembly.
7. Reattach the air filter cover and snap in place.

# MAINTENANCE AND STORAGE

## Spark Arrester

1. Allow the engine to cool completely before servicing the spark arrester.
2. Remove the two screws holding the cover plate which retains the end of the spark arrester to the muffler.
3. Remove the spark arrester screen.
4. Carefully remove the carbon deposits from the spark arrester screen with a wire brush.
5. Replace the spark arrester if it is damaged.
6. Position the spark arrester in the muffler and attach with the two screws.

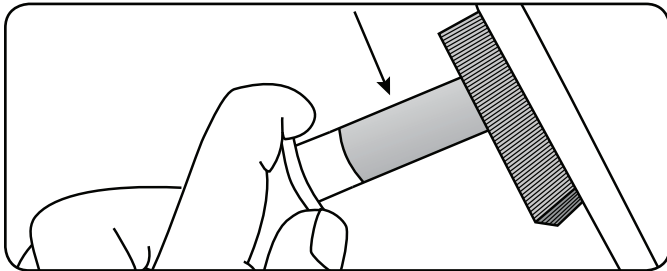

### ! CAUTION

Failure to clean the spark arrester will result in degraded engine performance.

### NOTE

Federal and local laws and administrative requirements indicate when and where spark arresters are required. When ordered, spark arresters are required for operation of this generator in National Forest lands. In California, this generator must not be used on any forest-covered land, brush-covered land, or grass-covered land unless the engine is equipped with a spark arrester.

## In-line Fuel Filter

1. Shut the fuel valve off.
2. Using needle nose pliers loosen the hose clamps on each side of the filter.
3. Remove old filter from fuel hoses.
4. Connect the new filter to the fuel hose on each side, making sure the flow arrow on the filter is pointing towards the carburetor. (A)
5. Using needle nose pliers work the hose clamps to a snug fit on each side of the fuel filter. (B)

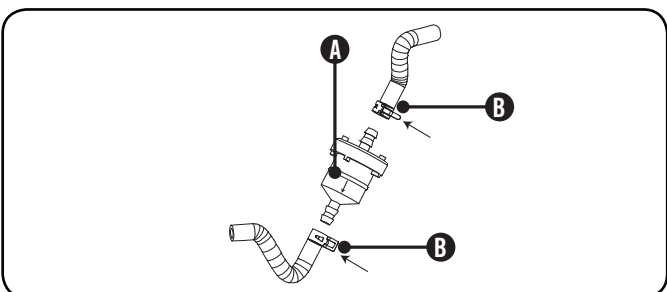

## Cleaning

### ! CAUTION

DO NOT spray engine with water.

Water can contaminate the fuel system.

Use a damp cloth to clean exterior surfaces of the engine. Use a soft bristle brush to remove dirt and oil. Use an air compressor (25 PSI) to clear dirt and debris from the engine.

## Adjustments

The air-fuel mixture is not adjustable. Tampering with the governor can damage your generator and your electrical devices and will void your warranty. CPE recommends that you contact our service line at **1-877-338-0999** for all other service and/or adjustment needs.

## Maintenance Schedule

Follow the service intervals indicated in the following maintenance schedule.

Service your generator more frequently when operating in adverse conditions.

Contact our helpline at **1-877-338-0999** to locate the nearest Champion Power Equipment certified service dealer for your generator or engine maintenance needs.

Every 8 hours or daily	
	Check oil level
	Clean around air intake and muffler
First 5 Hours	
	Change oil
Every 50 hours or every season	
	Clean air filter
	Change oil if operating under heavy load or in hot environments
Every 100 hours or every season	
	Change oil
	Clean/Adjust spark plug
	Check/Adjust valve clearance *
	Clean spark arrester
	Clean fuel tank and filter *
Every 250 hours	
	Clean combustion chamber*
Every 3 years	
	Replace fuel line

\*To be performed by knowledgeable, experienced owners or Champion Power Equipment certified dealers.

## Generator Maintenance

Make certain that the generator is kept clean and stored properly. Only operate the unit on a flat, level surface in a clean, dry operating environment. DO NOT expose the unit to extreme conditions, excessive dust, dirt, moisture or corrosive vapors.

### ⚠ CAUTION

DO NOT use a garden hose to clean the generator.

Water can enter the generator through the cooling slots and damage the generator windings.

Use a damp cloth to clean exterior surfaces of the generator. Use a soft bristle brush to remove dirt and oil. Use an air compressor (25 PSI) to clear dirt and debris from the generator. Inspect all air vents and cooling slots to ensure that they are clean and unobstructed.

## Storage

The generator should be started at least once every 14 days and allowed to run for at least 20 minutes. For longer term storage, please follow these guidelines.

### Generator Storage

1. Add a properly formulated fuel stabilizer to the tank.
2. Be sure all appliances are disconnected from the generator.
3. Run the generator for a few minutes so the treated fuel cycles through the fuel system and carburetor.
4. Turn the fuel valve to the "Off" position.
5. Let the generator run until fuel starvation has stopped the engine. This usually takes a few minutes.
6. The generator needs to cool completely before cleaning and storage.
7. Clean the generator according to the maintenance section.
8. Change the oil.
9. Remove the spark plug and pour about 1/2 ounce of oil into the cylinder. Crank the engine slowly to distribute the oil and lubricate the cylinder.
10. Reattach the spark plug.
11. Store the unit in a clean, dry place out of direct sunlight.

## Generator Storage Cont'd.

### NOTE

Our engines work well with 10% or less ethanol blend fuels. When using blended fuels there are some issues worth noting:

- Ethanol-gasoline blends can absorb more water than gasoline alone.
- These blends can eventually separate, leaving water or a watery goo in the tank, fuel valve and carburetor.
- With gravity-fed fuel supplies, this compromised fuel can be drawn into the carburetor and cause damage to the engine and/or potential hazards.
- There are only a few suppliers of fuel stabilizer that are formulated to work with ethanol blend fuels.
- Any damages or hazards caused by using improper fuel, improperly stored fuel, and/or improperly formulated stabilizers, are not covered by manufacture's warranty.

It is advisable to always shut off the fuel supply, run the engine to fuel starvation and drain the tank when the equipment is not in use for more than 30 days.

### ⚡ DANGER

Generator exhaust contains odorless and colorless carbon monoxide gas.

To avoid accidental or unintended ignition of your generator during periods of storage, the following precautions should be followed:

- When **storing the generator for short or extended periods of time** make sure that the Engine Switch and the Fuel Valve are set in the **OFF** position.

# SPECIFICATIONS

## Engine Specifications

- Model . . . . . 66534
- Displacement . . . . . 196cc
- Type . . . . . 4-Stroke OHV
- Start Type . . . . . Recoil

## Generator Specifications

- Model . . . . . 46597
- Running Wattage . . . . . 3500 Watts
- Starting Wattage . . . . . 4000 Watts
- AC Load . . . . . 120 V
- Phase . . . . . Single
- Frequency . . . . . 60 Hz
- Fuel Capacity . . . . . 3.8 gal. (14.4 L)
- Gross Weight . . . . . 113.5 lbs (51.5 kg)
- Net Weight . . . . . 105.8 lbs (48 kg)
- Height . . . . . 20.9 inches (53 cm)
- Width . . . . . 23.2 inches (59 cm)
- Length . . . . . 23.5 inches (59.6 cm)

## Fuel

Fuel capacity is 3.8 gal. (14.4 L). Use regular unleaded gasoline with a minimum octane rating of 85 and an ethanol content of less than 10% by volume.

## Oil

Use 4-Cycle automotive oil.

Oil capacity is up to 0.63 qt. (0.6 L).

Please reference the following chart for recommended oil types for use in the generator.

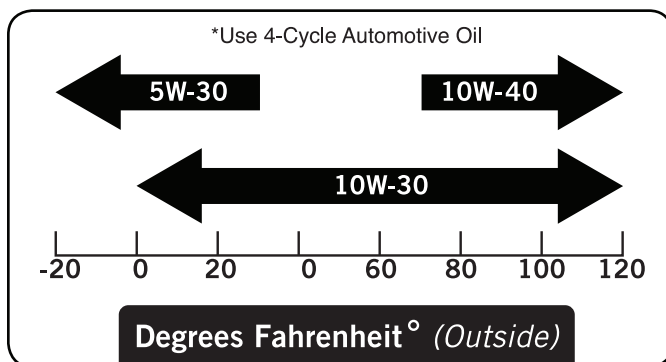

## Spark Plugs

**OEM spark plug:** NHSP F6RTC

**Replacement spark plug:** NGK BPR6ES or equivalent  
Make certain the spark plug gap is 0.7 - 0.8 mm or (0.028 - 0.031 in.).

## Maintenance Valve Clearance

- Intake: 0.13 – 0.17 mm (0.005 – 0.007 in.)
  - Exhaust: 0.18 – 0.22 mm (0.007 – 0.009 in.)
- Note: Tech bulletin regarding the valve adjustment procedure is on [www.championpowerequipment.com](http://www.championpowerequipment.com).

Wiring Diagram

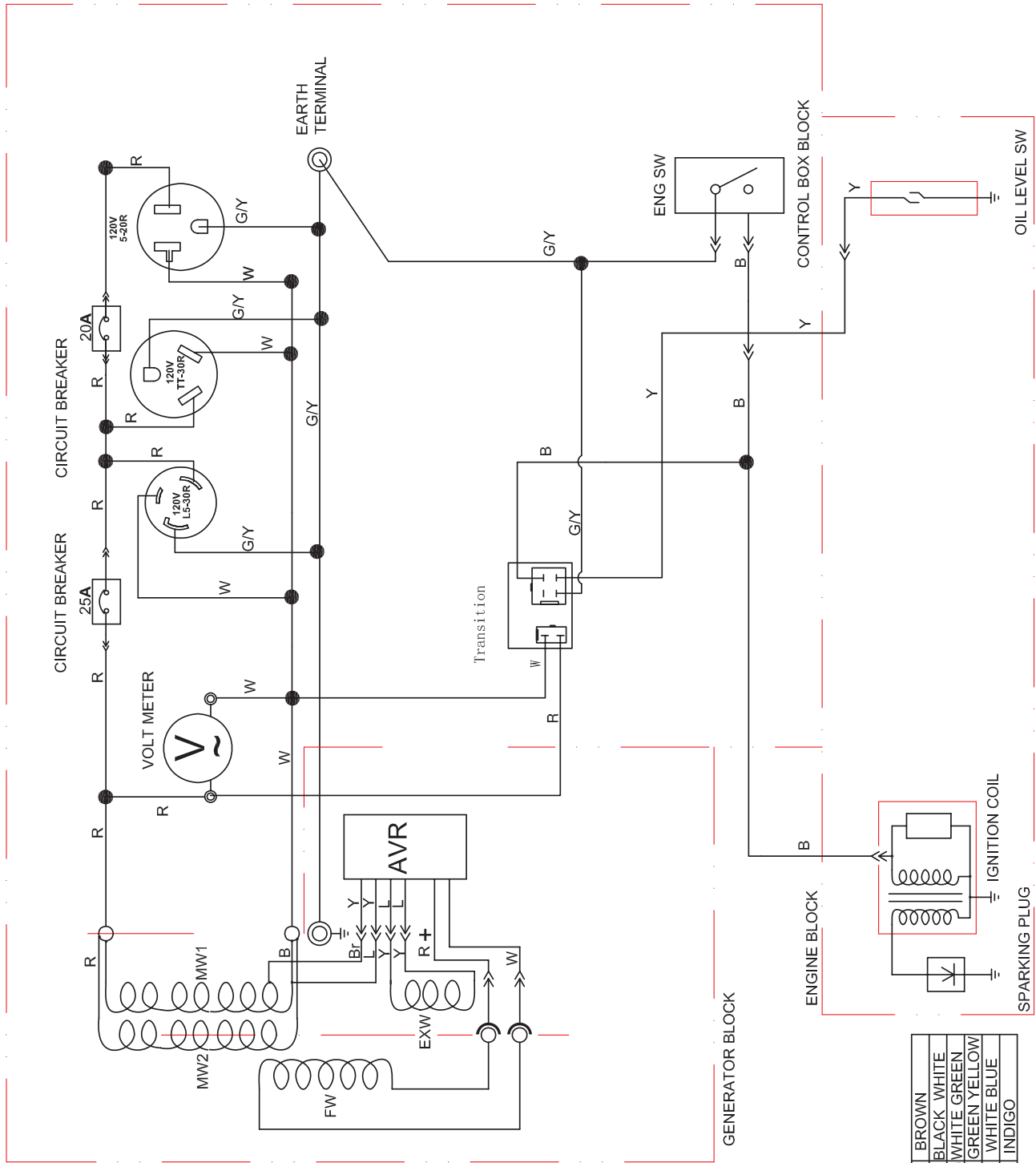

B	BLACK	Br	BROWN
Y	YELLOW	B/W	BLACK WHITE
L	BLUE	W/G	WHITE GREEN
G	GREEN	G/Y	GREEN YELLOW
R	RED	W/L	WHITE BLUE
W	WHITE	In	INDIGO

# SPECIFICATIONS

## Parts Diagram

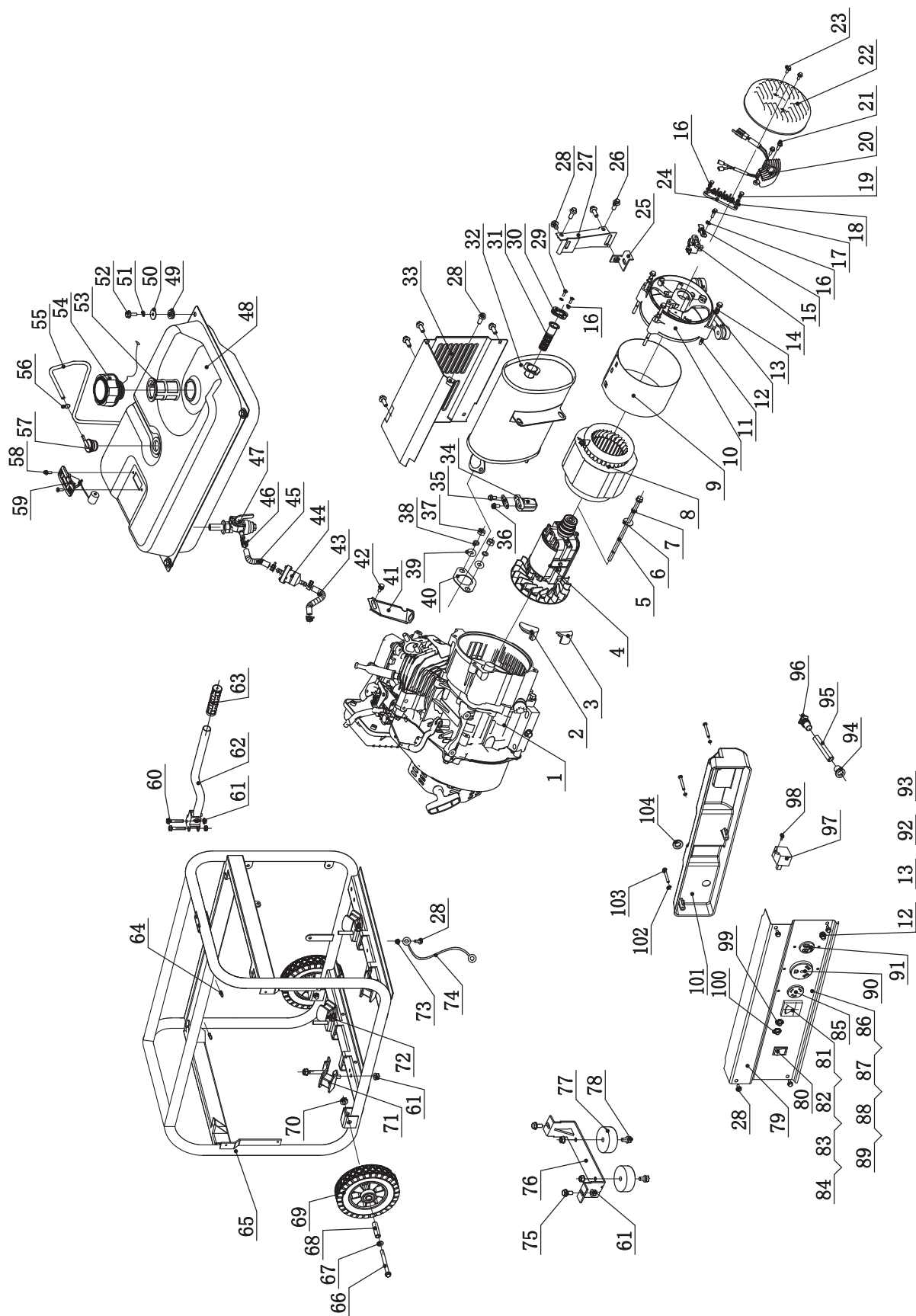

#	Part Number	Description	Qty
1	168FD-2-GC	Engine	1
2	ST02FD-02100011	Plug-B	1
3	ST02FD-02100012	Plug-A	1
4	504.191100.04	Rotor Assembly	1
5	ST02FD-02100005-2.5	Flange Bolt M8x233	1
6	GB90-W-8	Washer 8	1
7	GB93-LW-8	Lock Washer 8	1
8	504.191200.04	Stator Assembly	1
9	ST02FD-02100002	Stator Cover	1
10	ST02FD-02100003	End Housing	1
11	ST02FD-02100001-2.5	Flange Bolt M6x158	4
12	GB90-W-6	Washer 6	6
13	GB93-LW-6	Lock Washer 6	10
14	ST02FD-02100009	Carbon Brush Assembly	1
15	ST02FD-02100008	Brush Support Plate	1
16	GB93-LW-5	Lock Washer 5	5
17	GB5781-B5-16	Bolt M5x16	1
18	GB90-W-5	Washer 5	2
19	GB5781-B5-16	Bolt M5x16	2
20	ST02FD-02100007-CPE	AVR	1
21	GB5789-FB5-16	Flange Bolt M5x16	2
22	ST02FD-02100004-Y	Generator End Cover	1
23	GB5789-FB5-12	Flange Bolt M5x12	2
24	ST02FD-02100010	Terminal Block	1
25	ST02FD-1150200	Holder (I), Muffler	1
26	GB5789-FB8-20	Flange Bolt M8x20	3
27	ST02FD-1150100	Holder (II), Muffler	1
28	GB5789-FB6-12	Flange Bolt M6x12	10
29	GB1667-S5-14	Screw M5x15	2
30	ST188FD-1100010-88	Cover, Spark Arrester	1
31	ST188FD-1180121	Spark Arrester	1
32	ST168FD-1100000-GC	Muffler	1
33	ST02FD-03030400	Muffler Cover	1
34	ST168FD-1100300-CARB	SAI Valve	1
35	ST168FD-1100003-CARB	Gasket, SAI Valve	1
36	GB5789-FB6-16	Flange Bolt M6x16	2
37	GB41-N-8	Nut M8	2
38	GB93-LW-8	Lock Washer 8	2
39	GB90-W-8	Washer 8	2
40	ST168F-1100200-G	Muffler Gasket	1
41	ST168FD-1090006-A	Holder, Air Cleaner	1
42	GB5789-FB6-8	Flange Bolt M6x8	1
43	504.070011.01	Pipe, Fuel	1
44	504.070500.01	Fuel Cleaner	1
45	504.070011.00	Pipe, Fuel	1
46	ST188FD-1070006-A	Clip	4
47	ST02FD-04160000	Fuel Cock	1
48	504.071000.35-Y	Fuel Tank	1
49	ST02FD-04100010	Vibration Mount, Fuel Tank	4
50	ST02FD-04100014	Washer 6	4
51	GB93-LW-6	Lock Washer 6	4
52	GB5789-FB6-20	Flange Bolt M6x20	4
53	ST168F-1070006-A	Fuel Filter	1
54	168.070100.01	Fuel Tank Cap	1
55	168.070014.01	Pipe, Reversal Valve	1
56	ST160F-1070007	Clamp	1

#	Part Number	Description	Qty
57	ST168F-1070400-CARB	Reversal Valve	1
58	GB1667-S5-10	Screw M5x10	2
59	ST02FD-04120000-CARB	Fuel Meter Assembly	1
60	GB5789-FB8-45	Flange Bolt M8x45	2
61	GB41-N-8	Nut M8	14
62	ST182FD-1151110-B	Handle	1
63	ST188FD-1741002-C	Sheath, Handle	1
64	ST168FD-1070408-CARB	Clamp	2
65	504.201100.58-F	Frame	1
66	GB5781-B10-105	Bolt M10x105	2
67	GB90-W-10	Flat Washer 10	2
68	ST02FD-03621001	Bushing 10.5x58.5	2
69	ST177FD-1152300-Y	8" Wheel	2
70	GB41-N-10	Nut M10	2
71	504.201200.00	Motor Mount I	2
72	504.201200.01	Motor Mount II	2
73	GB41-N-6	Nut M6	1
74	ST02FD-02100013-2.5	Grounding Line	1
75	GB5789-FB8-16	Flange Bolt M8x16	2
76	ST05FD-03020301-60	Support Leg 2.36	1
77	ST188FD-1743002-C	Vibration Mount	2
78	GB5789-FB8-25	Flange Bolt M8x25	2
79	2A104	Control Panel	1
80	ST02FD-05702004	Ignition Switch	1
81	ST02FD-05602010-D	Voltage Meter	1
82	GB90-W-3	Washer 3	4
83	GB93-LW-3	Lock washer 3	4
84	GB41-N-3	Nut M3	4
85	ST02FD-05502020	L5-30R Receptacle	1
86	GB1667-S4-14	Screw M4x14	6
87	GB90-W-4	Washer 4	6
88	GB93-LW-4	Lock Washer 4	6
89	GB41-N-4	Nut M4	6
90	ST02FD-05502029	RV Receptacle	1
91	ST02FD-05502024	Receptacle 5-20R	1
92	GB5781-B6-22	Bolt M6x22	1
93	GB41-N-6	Nut M6	2
94	ST02FD-05212002	Plug	1
95	ST02FD-05202003	Sheath, Wire	1
96	ST02FD-05212001	Plug	1
97	OV01-00000000	Over Voltage Protector	1
98	GB1667-S5-14	Screw M5x14	1
99	ST02FD-05302001-L25	AC.25A CIRCUIT BREAKERS	1
100	ST02FD-05302001-L20	AC.20A CIRCUIT BREAKERS	1
101	ST02FD-05202002.1	Control Box	1
102	GB90-W-5	Washer 5	3
103	GB1667-S5-38	Screw M5x38	3
104	ST02FD-05212001	Plug	1

# SPECIFICATIONS

## Engine Parts Diagram

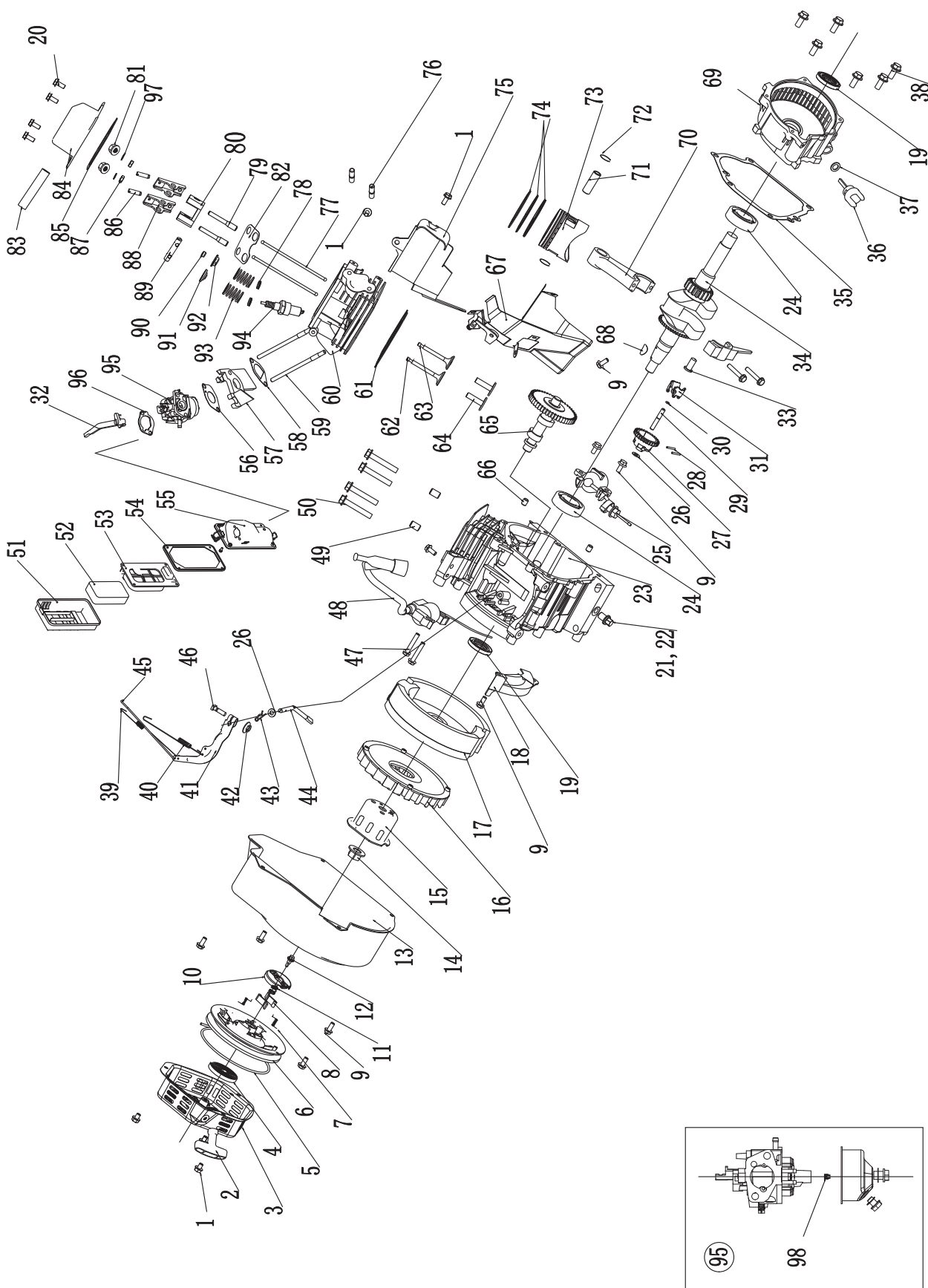



#	Part Number	Description	Qty
1	GB5789-FB6-8	Flange Bolt 6x8	5
2	ST160F-1061200	Recoil Starter Knob	1
3	ST160F-1061100-Q	Recoil Starter Comp	1
4	ST160F-1061005	Recoil Starter Spring	1
5	ST160F-1061009	Recoil Starter Rope	1
6	ST160F-1061001-A	Recoil Starter Reel	1
7	ST188F-1060006	Spring, Ratchet	2
8	ST188F-1060005	Starter Ratchet (Metal)	2
9	GB5789-FB6-12	Flange Bolt M6x12	9
10	ST188F-1060003	Ratchet Guide	1
11	ST188F-1060004	Ratchet Guide Spring	1
12	ST188F-1060002	Screw, Ratchet Guide	1
13	ST168F-1080100-G	Fan Cover Assembly	1
14	ST160F-1050010	Nut M14	1
15	ST160F-1060001-A	Start Hub	1
16	ST168F-1080001	Cooling Fan	1
17	ST168F-1120100	Flywheel	1
18	ST168F-1080200	Air Guide (II)	1
19	ST168F-1030100	Oil Seal	2
20	GB5789-FB6-15	Flange Bolt M6x15	4
21	ST160F-1030003	Drain Bolt	2
22	ST160F-1030004	Washer, Drain Bolt	2
23	ST168F-2-1030012-G	Crankcase	1
24	GB276-BB-6205-UU	Radial Ball Bearing 6205 Unsealed	2
25	ST160F-1127000-A	Oil Level Sensor	1
26	ST160F-1110108	Washer, Governor (II)	1
27	ST160F-1110101	Governor Gear	1
28	ST160F-1110102	Pin, Governor Weight	2
29	ST160F-1110104	Shaft, Governor Gear	1
30	ST160F-1110103	Circlip, Governor Gear	1
31	ST160F-1110107	Governor Weight	2
32	ST02FD-1151201A	Choke Lever	1
33	ST160F-1110105-A	Bushing, Governor	1
34	ST168FD-2-1050001-A	Crankshaft Assembly	1
35	ST168F-1030008-G	Gasket, Crankcase	1
36	ST160F-1030001-B	Oil Dipstick	1
37	ST160F-1030002	Gasket, Oil Dipstick	2
38	GB5789-FB8-32	Flange Bolt 8x32	6
39	ST168F-1110005	Spring, Throttle Return	1
40	ST168F-1110007	Spring, Governor	1
41	ST160F-1110003	Arm, Governor	1
42	GB41-N-6	Nut M6	3
43	ST160F-1110008	Pin, Shaft	1
44	ST160F-1110001	Shaft, Governor Arm	1
45	ST168F-1110006	Rod, Governor	1
46	ST160F-1110004	Bolt, Governor Arm	1
47	GB5789-FB6-25	Flange Bolt 6x25	2
48	ST160F-1123000-G	Ignition Coil	1
49	152FMD-1001007	Dowel Pin 10x16	2
50	GB5789-FB8-55	Flange Bolt 8x55	4
51	ST168FD-1090005-G	Cover, Air Cleaner	1
52	ST168FD-1090004	Element	1
53	ST168FD-1090003	Separator	1
54	ST168FD-1090002	Air Cleaner Seal	1
55	ST168FD-1091000-CARB	Case, Air Cleaner	1
56	ST160F-1130003-CPE	Gasket, Carburetor	1

#	Part Number	Description	Qty
57	ST168F-1130001	Insulator, Carburetor	1
58	ST168F-1130002-CPE	Gasket, Insulator	1
59	ST160F-1010001	Stud Bolt 6x113	2
60	ST168F-2-1010100-G	Cylinder Head	1
61	ST168F-2-1030009-G	Gasket, Cylinder Head	1
62	ST168F-1040002	Valve, Intake	1
63	ST168F-1040006	Valve, Exhaust	1
64	ST168F-2-1040013	Lifter, Valve	2
65	ST168F-2-1041000	Camshaft Assembly	1
66	ST168F-1030015-G	Dowel Pin 9x14	2
67	ST168FD-1080200-CARB	Air Shroud, Cylinder	1
68	GB1099-79	Key	1
69	ST168FD-1030007-G	Crankcase Cover	1
70	ST168F-1050100	Connecting Rod Assembly	1
71	ST168F-1050003	Wrist Pin	1
72	ST168F-1050004	Circlip, Wrist Pin	2
73	ST168F-2-1050005	Piston	1
74	ST168F-1050007	Ring, First	1
	ST168F-1050006	Ring, Second	1
	ST168F-1050200	Ring, Oil	1
75	ST168F-1080002-GC	Gasket, Cylinder Head (I)	1
76	GB900-SB8-35	Stud Bolt	2
77	ST168F-1040005	Push Rod	2
78	ST168F-1040014-A	Oil Seal, Valve	2
79	ST168F-1040027	Stud Bolt, Rocker Arm	2
80	168.040201.34	Retainer, Rocker Arm	1
81	GB41-N-6	Nut M6	2
82	168.040004.34	Guide Plate, Push Rod	1
83	ST168FD-1020011-A	Breather Tube	1
84	ST168F-1020100-C	Cylinder Cover Assembly	1
85	ST160F-1020002-A	Gasket, Cylinder Cover	1
86	ST160F-1040024	Adjustment Screw, Valve	2
87	ST160F-1040025	Locknut	2
88	ST160F-1040022	Rocker Arm	2
89	168.040202.34	Shaft, Rocker Arm	1
90	ST160F-1040008	Rotator, Exhaust Valve	1
91	ST160F-1040001	Retainer, Intake Valve	1
92	ST160F-1040007	Retainer, Exhaust Valve	1
93	ST160F-1040003	Spring, Valve	2
94	F6RTC	Spark Plug	1
95	ST168FD-2-1131000	Carburetor	1
96	ST168FD-1130005-CPE	Gasket, Carburetor	1
97	GB90-W-6	Washer 6	2
98	ST168FD-2-1131000-17	Standard Main Jet	1
	ST168F-2-1131000-17	Altitude Main Jet	/

# TROUBLESHOOTING

Problem	Cause	Solution
Generator will not start	No fuel	Add fuel
	Faulty spark plug	Replace spark plug
	Unit loaded during start up	Remove load from unit
Generator will not start;	Low oil level	Fill crankcase to the proper level
		Place generator on a flat, level surface
Generator starts but runs roughly	Choke in the wrong position.	Adjust choke.
	Spark plug wire loose	Attach wire to spark plug
Generator shuts down during operation	Out of fuel	Fill fuel tank
	Low oil level	Fill crankcase to the proper level. Place generator on a flat, level surface
Generator cannot supply enough power or overheating	Generator is overloaded	Review load and adjust. See "Power Management"
	Insufficient ventilation	Check for air restriction. Move to a well ventilated area
No AC output	Cable not properly connected	Check all connections
	Connected device is defective	Replace defective device
	Circuit breaker is open	Reset circuit breaker
	Faulty brush assembly	Replace brush assembly (Service Center)
	Faulty AVR (auto voltage regulator)	Replace AVR (Service Center)
	Loose wiring	Inspect and tighten wiring connections
	Other	Contact the help line.
Generator gallops	Engine governor defective	Contact the help line
Repeated circuit breaker tripping	Overload	Review load and adjust. See "Power Management"
	Faulty cords or device	Check for damaged, bare or frayed wires. Replace defective device

## For further technical support:

### Technical Service

Mon – Fri 8:30 AM – 5:00 PM (PST/PDT)

Toll Free: 1-877-338-0999

tech@championpowerequipment.com

**WARRANTY**

CHAMPION POWER EQUIPMENT  
2 YEAR LIMITED WARRANTY

**Warranty Qualifications**

Champion Power Equipment (CPE) will register this warranty upon receipt of your Warranty Registration Card and a copy of your sales receipt from one of CPE's retail locations as proof of purchase.

Please submit your warranty registration and your proof of purchase within ten (10) days of the date of purchase.

**Repair/Replacement Warranty**

CPE warrants to the original purchaser that the mechanical and electrical components will be free of defects in material and workmanship for a period of one year (parts and labor) and two years (parts) from the original date of purchase (90 days (parts and labor) and 180 days (parts) for commercial & industrial use). Transportation charges on product submitted for repair or replacement under this warranty are the sole responsibility of the purchaser. This warranty only applies to the original purchaser and is not transferable.

**Do Not Return The Unit To The Place Of Purchase**

Contact CPE's Technical Service and CPE will troubleshoot any issue via phone or e-mail. If the problem is not corrected by this method, CPE will, at its option, authorize evaluation, repair or replacement of the defective part or component at a CPE Service Center. CPE will provide you with a case number for warranty service. Please keep it for future reference. Repairs or replacements without prior authorization, or at an unauthorized repair facility, will not be covered by this warranty.

**Warranty Exclusions**

This warranty does not cover the following repairs and equipment:

**Normal Wear**

Generators need periodic parts and service to perform well. This warranty does not cover repair when normal use has exhausted the life of a part or the equipment as a whole.

**Installation, Use and Maintenance**

This warranty will not apply to parts and/or labor if this generator is deemed to have been misused, neglected, involved in an accident, abused, loaded beyond the generator's limits, modified, installed improperly or connected incorrectly to any electrical component.

**Installation, Use and Maintenance Cont'd.**

Normal maintenance such as spark plugs, air filters, adjustments, fuel system cleaning and obstruction due to buildup is not covered by this warranty.

**Other Exclusions**

This warranty excludes:

- Cosmetic defects such as paint, decals, etc.
- Wear items such as filter elements, o-rings, etc.
- Accessory parts such as starting batteries, and storage covers.
- Failures due to acts of God and other force majeure events beyond the manufacturer's control.
- Problems caused by parts that are not original Champion Power Equipment parts.

This warranty does not apply to generators used for prime power in place of a utility.

**Limits of Implied Warranty and Consequential Damage**

Champion Power Equipment disclaims any obligation to cover any loss of time, use of this product, freight, or any incidental or consequential claim by anyone from using this generator. THIS WARRANTY IS IN LIEU OF ALL OTHER WARRANTIES, EXPRESS OR IMPLIED, INCLUDING WARRANTIES OF MERCHANTABILITY OR FITNESS FOR A PARTICULAR PURPOSE.

A unit provided as an exchange will be subject to the warranty of the original unit. The length of the warranty governing the exchanged unit will remain calculated by reference to the purchase date of the original unit.

This warranty gives you certain legal rights which may change from state to state. Your state may also have other rights you may be entitled to that are not listed within this warranty.

**Contact Information****Address**

Champion Power Equipment, Inc.  
Customer Service  
10006 Santa Fe Springs Rd.  
Santa Fe Springs, CA 90670  
[www.championpowerequipment.com](http://www.championpowerequipment.com)

**Customer Service**

Mon – Fri 8:30 AM – 5:00 PM (PST/PDT)  
Toll Free: 1-877-338-0999  
[info@championpowerequipment.com](mailto:info@championpowerequipment.com)  
Fax no.: 1-562-236-9429

**Technical Service**

Mon – Fri 8:30 AM – 5:00 PM (PST/PDT)  
Toll Free: 1-877-338-0999  
[tech@championpowerequipment.com](mailto:tech@championpowerequipment.com)  
24/7 Tech Support: 1-562-204-1188

**Champion Power Equipment, Inc. (CPE),  
and the United States Environment Protection Agency (U.S. EPA.)  
Emission Control System Warranty**

Your Champion Power Equipment (CPE) engine complies with the U.S. EPA emission regulations.

**YOUR WARRANTY RIGHTS AND OBLIGATIONS:**

The US EPA AND CPE are pleased to explain the Federal Emission Control Systems Warranty on your 2012 small off-road engine and engine powered equipment. New engines and equipment must be designed, built and equipped, at the time of sale, to meet U.S. EPA regulations for small non-road engines. CPE warrants the emission control system on your small off-road engine and equipment for the period of time listed below, provided there has been no abuse, neglect, unapproved modification, or improper maintenance of your equipment.

Your emission control system may include parts such as the carburetor, fuel-injection system, the ignition system, catalytic converter and fuel lines. Also included may be hoses, belts, connectors and other emission related assemblies. Where a warrantable condition exists, CPE will repair your small off-road engine at no cost to you including diagnosis, parts and labor.

**MANUFACTURER'S EMISSION CONTROL SYSTEM WARRANTY COVERAGE:**

This emission control system is warranted for two years, subject to provisions set forth below. If, during the warranty period, emission related part on your engine is defective in materials or workmanship, the part will be repaired or replaced by CPE.

**OWNER WARRANTY RESPONSIBILITIES:**

As the small off-road engine owner, you are responsible for the performance of the required maintenance listed in your Owner's Manual. CPE recommends that you retain all your receipts covering maintenance on your small off-road engine, but CPE cannot deny warranty solely for the lack of receipts or for your failure to ensure the performance of all scheduled maintenance.

As the small off-road engine owner, you should however be aware that CPE may deny you warranty coverage if your small, off-road engine or a part has failed due to abuse, neglect, improper maintenance or unapproved modifications.

You are responsible for presenting your small off-road engine to an Authorized CPE service outlet or alternate service outlet as described in (3)(f.) below, CPE dealer or CPE, Santa Fe Springs, Ca. as soon as a problem exists. The warranty repairs should be completed in a reasonable amount of time, not to exceed 30 days.

If you have any questions regarding your warranty rights and responsibilities, you should contact:

Champion Power Equipment, Inc.  
Customer Service  
10006 Santa Fe Springs Road  
Santa Fe Springs, CA 90670  
1-877-338-0999

## **EMISSION CONTROL SYSTEM WARRANTY**

**The following are specific provisions relative to your Emission Control System Warranty Coverage.**

**1. APPLICABILITY:** This warranty shall apply to 1997 and later model year small off-road engines. The ECS Warranty Period shall begin on the date the new engine or equipment is delivered to its original, end-use purchaser, and shall continue for 24 consecutive months thereafter.

### **2. GENERAL EMISSIONS WARRANTY COVERAGE**

CPE warrants to the original, end-use purchaser of the new engine or equipment and to each subsequent purchaser that each of its small off-road engines is:

a. Designed, built and equipped so as to conform at the time of sale with applicable regulations under section 213 of the Clean Air Act, as amended, 42 U.S.C. 7401 et seq.

b. Free from defects in materials and workmanship that cause the failure of a warranted part to be identical in all material respects to the part as described in the engine manufacturer's application for certification for a period of two years.

### **3. THE WARRANTY ON EMISSION-RELATED PARTS WILL BE INTERPRETED AS FOLLOWS:**

a. Any warranted part that is not scheduled for replacement as required maintenance in the Owners Manual shall be warranted for the ECS Warranty Period. If any such part fails during the ECS Warranty Period, it shall be repaired or replaced by CPE according to Subsection "d" below. Any such part repaired or replaced under the ECS Warranty shall be warranted for any remainder of the ECS Warranty Period.

b. Any warranted, emissions-related part which is scheduled only for regular inspection as specified in the Owners Manual shall be warranted for the ECS Warranty Period. A statement in such written instructions to the effect of "repair or replace as necessary", shall not reduce the ECS Warranty Period. Any such part repaired or replaced under the ECS Warranty shall be warranted for the remainder of the ECS Warranty Period.

c. Any warranted, emissions-related part which is scheduled for replacement as required maintenance in the Owner's Manual shall be warranted for the period of time prior to the first scheduled replacement point for that part. If the part fails prior to the first scheduled replacement, the part shall be repaired or replaced by CPE according to Subsection "d" below. Any such emissions-related part repaired or replaced under the ECS Warranty, shall be warranted for the remainder of the ECS Warranty Period prior to the first scheduled replacement point for such emissions-related part.

d. Repair or replacement of any warranted, emissions-related part under this ECS Warranty shall be performed at no charge to the owner at a CPE Authorized Service Outlet.

e. The owner shall not be charged for diagnostic labor which leads to the determination that a part covered by the ECS Warranty is in fact defective, provided that such diagnostic work is performed at a CPE Authorized Service Outlet.

f. CPE shall pay for covered emissions warranty repairs at non-authorized service outlets under the following circumstances:

i. The service is required in a population center with a population over 100,000 according to U.S. Census 2000 without a CPE Authorized Service Outlet AND

ii. The service is required more than 100 miles from a CPE Authorized Service Outlet. The 100 mile limitation does not apply in the following states: Alaska, Arizona, Colorado, Hawaii, Idaho, Montana, Nebraska, Nevada, New Mexico, Oregon, Texas, Utah and Wyoming.

g. CPE shall be liable for damages to other original engine components or approved modifications proximately caused by a failure under warranty of an emission-related part covered by the ECS Warranty.

h. Throughout the ECS Warranty Period, CPE shall maintain a supply of warranted emission-related parts sufficient to meet the expected demand for such emission-related parts.

i. Any CPE Authorized and approved emission-related replacement part may be used in the performance of any ECS Warranty maintenance or repair and will be provided without charge to the owner. Such use shall not reduce CPE's warranty obligation.

j. Unapproved add-on or modified parts may not be used to modify or repair a CPE engine. Such use voids this ECS Warranty and shall be sufficient grounds for disallowing an ECS Warranty claim. CPE shall not be liable hereunder for failures of any warranted parts of a CPE engine caused by the use of such an unapproved add-on or modified part.

**EMISSION-RELATED PARTS INCLUDE THE FOLLOWING: (using those portions of the list applicable to the engine)**

Systems covered by this warranty	Parts Description
Fuel Metering System	Fuel regulator, Carburetor and internal parts
Air Induction System	Air cleaner, Intake manifold
Ignition System	Spark plug and parts, Magneto ignition system
Exhaust System	Exhaust manifold, catalytic converter
Miscellaneous Parts	Tubing, Fittings, Seals, Gaskets, and Clamps associated with these listed systems.
Evaporative Emissions	Fuel Tank, Fuel Cap, Fuel Line, Fuel Line Fittings, Clamps, Pressure Relief Valves, Control Valves, Control Solenoids, Electronic Controls, Vacuum Control Diaphragms, Control Cables, Control Linkages, Purge Valves, Vapor Hoses, Liquid/Vapor Separator, Carbon Canister, Canister Mounting Brackets, Carburetor Purge Port Connector

**TO OBTAIN WARRANTY SERVICE:**

You must take your CPE engine or the product on which it is installed, along with your warranty registration card or other proof of original purchase date, at your expense, to any Champion Power Equipment dealer who is authorized by Champion Power Equipment, Inc. to sell and service that CPE product during his normal business hours. Alternate service locations defined in Section (3)(f.) above must be approved by CPE prior to service. Claims for repair or adjustment found to be caused solely by defects in material or workmanship will not be denied because the engine was not properly maintained and used.

**If you have any questions regarding your warranty rights and responsibilities, or to obtain warranty service, please write or call Customer Service at Champion Power Equipment, Inc.**

**Champion Power Equipment, Inc.  
10006 Santa Fe Springs Road  
Santa Fe Springs, CA 90670  
1-877-338-0999  
Attn.: Customer Service**