

GENTRON®

Owner's Manual 3500 WATT DIGITAL INVERTER GENERATOR

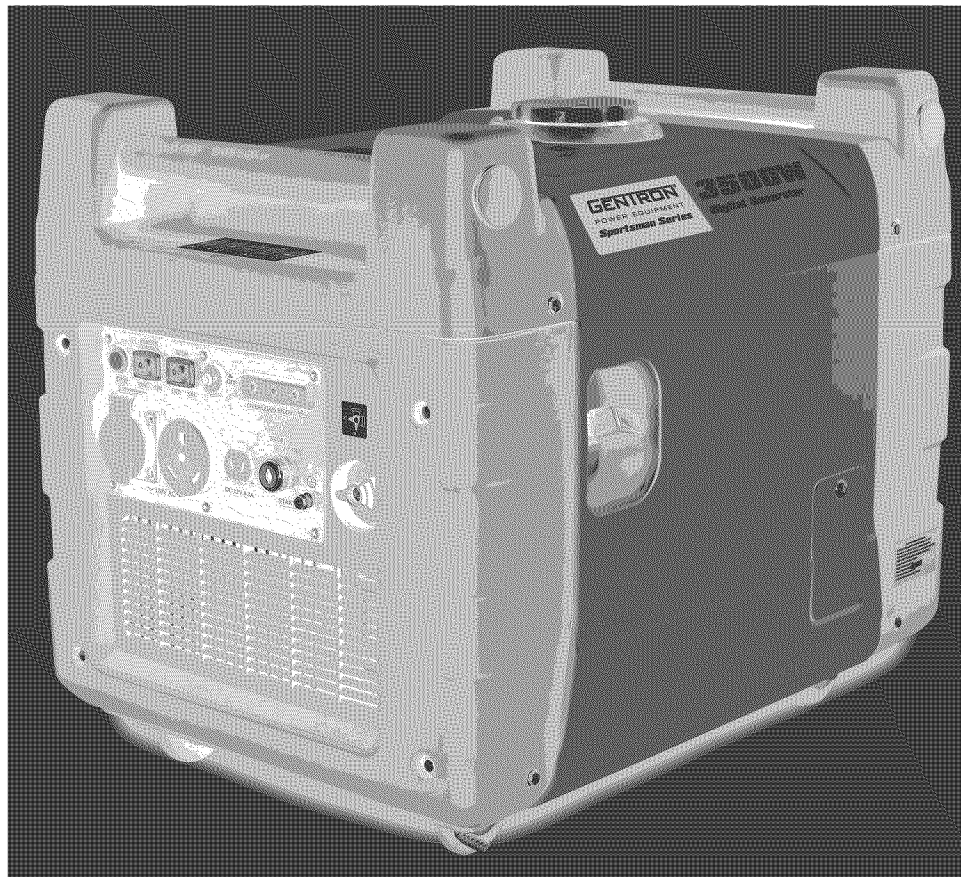

Please read and save these instructions.

HAVE QUESTIONS OR NEED SERVICE

DO NOT RETURN TO STORE!

PLEASE CALL TOLL FREE: 888.896.6881



www.GentronUSA.com

DANGER **Carbon Monoxide**

Using a generator indoors WILL KILL YOU IN MINUTES.

Carbon Monoxide

Generator exhaust contains high levels of carbon monoxide (CO), a poisonous gas you cannot see or smell. If you can smell the generator exhaust, you are breathing CO. But even if you cannot smell the exhaust, you could be breathing CO.

- NEVER use a generator inside homes, garages, crawlspaces, or other partly enclosed areas. Deadly levels of carbon monoxide can build up in these areas. Using a fan or opening windows and doors does NOT supply enough fresh air.
- ONLY use a generator outdoors and far away from open windows, doors, and vents. These openings can pull in generator exhaust.

Even when you use a generator correctly, CO may leak into the home. ALWAYS use a battery-powered or battery-backup CO alarm in the home.

If you start to feel sick, dizzy, or weak after the generator has been running, move to fresh air RIGHT AWAY. See a doctor. You could have carbon monoxide poisoning.

Preface

Thank you for using our generator.

This manual includes the operation and maintenance of the GG3500D

All information in this publication is based on the latest product information available at the time of approval for printing. We reserve the right to make changes at any time without notice and without incurring an obligation. The copyright of this manual belongs to our company. No parts of this publication may be reproduced without written permission.

This manual should be considered a permanent part of the generator and should remain with it if it is resold.

Pay special attention to statements preceded by the following words:

WARNING

It indicates a strong possibility of severe personal injury or death if instructions are not followed.

CAUTION

It indicates a strong possibility of severe personal injury or death if instruction is not followed.
If a problem should arise, or if you have any questions about the generator, consult an authorized dealer.

BE CAREFUL

The generator is designed to give safe and dependable service if operated according to instructions, read and understand the Owner's manual before operating the generator. Failure to do so could result in personal injury or equipment damage.

Safety Instruction

WARNING!

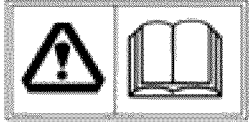

The generator is designed to give safe and dependable service if operated according to instructions. Read and understand this manual carefully before operating the generator or it may cause serious injury and equipment damage.

WARNING!

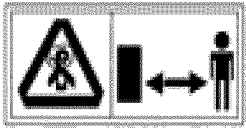

Exhaust contains poisonous carbon monoxide. Do not operate generator in confined environment or with an aerator. Only use outdoors and far from open windows doors and vents.

WARNING!

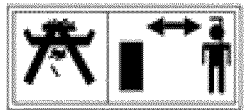

The muffler becomes very hot during operation and remains hot for a while after stopping the engine. Be careful not to touch the muffler while it is hot. Let the engine cool before storing the generator indoor. The engine exhaust system will be heated during operation and remains hot immediately after stopping the engine. To prevent scalding, pay more attention to the warning marks attached to the generator.

BE CAREFUL!

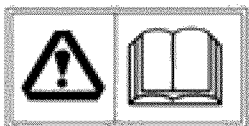

Do not parallel connect other cables to receptacles, use special jack, or it may cause an electrical shock.

Safety Instruction

WARNING!

- Gasoline is extremely flammable and is explosive under certain conditions. Refuel in a ventilated area with engine stopped.
- Keep away from cigarette, smoke and sparks when refueling the generator. Always refuel in a well-ventilated location.

WARNING!

- Connection for standby power to a building electrical system must be made by a qualified electrician. The connection must isolate the generator from utility power, and must comply with all applicable laws and electrical codes. Improper connections to a building electrical system can allow electrical current from the generator to back feed into the utility lines. Such back feed may electrocute utility company workers or others who contact lines during a power outage and the generator may explode, or cause fires when utility power is restored.

WARNING!

To avoid accidents and equipment damage, check generator system every time before starting engine.

- Keep the generator a distance of at least 1 meter from other equipment during operation.
- Keep the generator horizontal when running. If generator tilts, it may cause fuel spillage.
- Generator operators must be trained, must know how to stop the generator quickly and understand the operation of all controllable parts. Untrained operators should not be allowed to use this equipment.
- Keep children and pet away from operation area.
- Keep away from rotating parts during operation.
- The generator is a potential source of electrical shock when misused. Do not operate it with wet hands or in any wet location. Do not operate the generator in rain or snow. Do not allow unit to get wet.

Content

| | |
|---|----|
| 1. COMPONENT IDENTIFICATION | 6 |
| 2. SAFETY INSTRUCTIONS | 6 |
| 3. SAFETY LABEL LOCATIONS | 7 |
| 4. PRE-OPERATION CHECK | 8 |
| 4.1 Check the engine oil level | 8 |
| 4.2 Check the fuel level | 8 |
| 4.3 Check the air cleaner | 9 |
| 5. GENERATOR USE | 10 |
| 5.1 Starting the engine | 10 |
| 5.2 High altitude operation | 11 |
| 5.3 Generator use | 12 |
| 5.4 AC applications | 12 |
| 5.5 Output and Overload indicators | 13 |
| 5.6 DC applications | 14 |
| 5.7 Start the engine | 16 |
| 5.8 Oil alarm system | 16 |
| 5.9 Stop the engine | 16 |
| 6. MAINTENANCE | 18 |
| 6.1 Changing oil | 19 |
| 6.2 Air cleaner service | 21 |
| 6.3 Spark plug service | 21 |
| 6.4 Spark arrester service | 23 |
| 7. TRANSPORTATION AND STORAGE | 24 |
| 7.1 When transporting generator sets | 24 |
| 7.2 Before storing the units for an extended period | 24 |
| 8. TROUBLESHOOTING | 25 |
| 9. TECHNICAL DATA | 27 |
| 9.1 Size and weight | 27 |
| 9.2 Engine | 27 |
| 9.3 Generator | 27 |
| 10. Wiring diagram | 28 |
| 11. Parts diagram | 29 |
| 12. Parts list | 30 |

Digital Inverter Generator



WARNING!

Read this manual carefully before using the machine, for your own safety.

1 COMPONENT IDENTIFICATION

- | | |
|-----------------------|-------------------------------|
| 1. Fuel cap | 9. Overload indicator light |
| 2. Air vent knob | 10. Output indicator light |
| 3. Choke knob | 11. Oil alert indicator light |
| 4. Control panel | 12. Eco throttle switch |
| 5. Starting grip | 13. Engine switch |
| 6. Fuel valve grip | 14. DC socket |
| 7. Maintenance covers | 15. DC circuit breaker |
| 8. AC socket | 16. Grounding terminal |

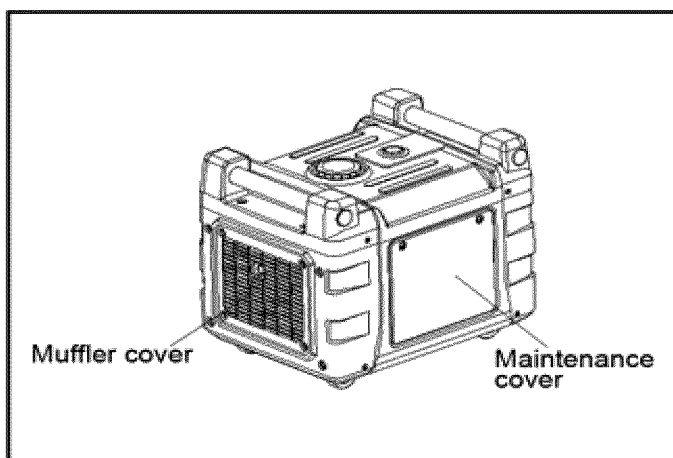
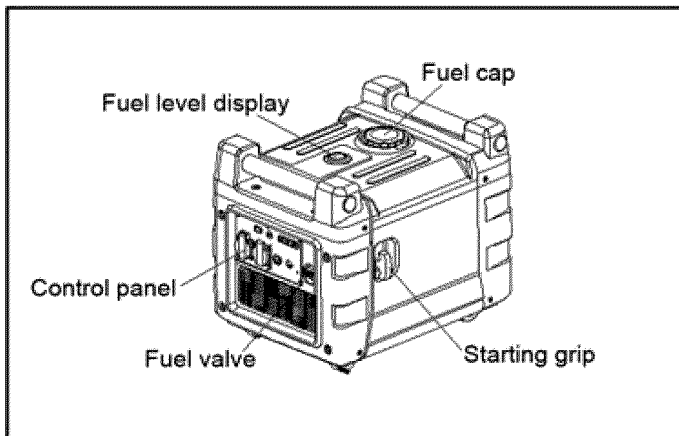

Control panel

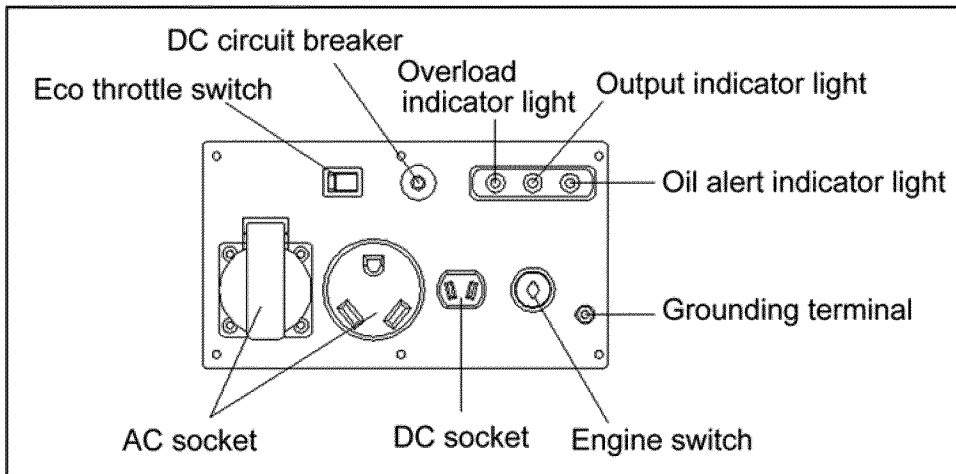

SMART THROTTLE

Engine speed is kept at idle automatically when the electrical appliance is disconnected and it returns to the proper speed to power of the electrical load when electrical appliance is connected. This position is recommended to minimize the fuel consumption while in operation.

2. SAFETY INSTRUCTIONS.

- The generator is designed to give safe and dependable service if operated according to instructions..
- Read and understand the Owner's Manual before operating the generator. Failure to do so could result in personal injury or equipment damage.
- Exhaust gas contains poisonous carbon monoxide. Never run the generator in an enclosed area. Be sure to provide adequate ventilation.
- The muffler becomes very hot during operation and remains hot for a while after stopping the engine. Be careful not to touch the muffler while it is hot. Let the engine cool before storing the generator indoors.
- The engine exhaust system will be heated during operation and remains hot immediately after stopping the engine. To prevent scalding, pay attention to the warning marks.
- Gasoline is extremely flammable and explosive under certain conditions. Refuel in a well-ventilated area with the engine stopped.
- Keep away from cigarette smoke and sparks when re-fueling the generator, Always refuel in a well ventilated location.
- Wipe up spilled gasoline at once.
- Connections for standby power to a building's electrical system must be made by a qualified electrician and must comply with all applicable laws and electrical codes. Improper connections can allow electrical current from the generator to back feed into the utility lines.

3. SAFETY LABEL LOCATIONS

These labels warn you for potential hazards that can cause serious injury. Read the labels and safety notes and precautions described in the manual carefully. If a label comes off or becomes hard to read, contact your dealer for a replacement.

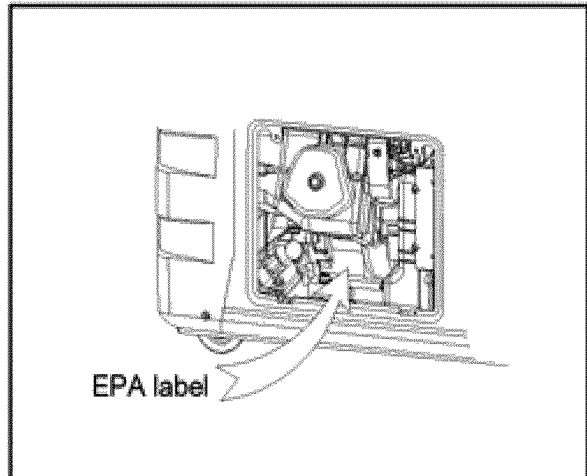
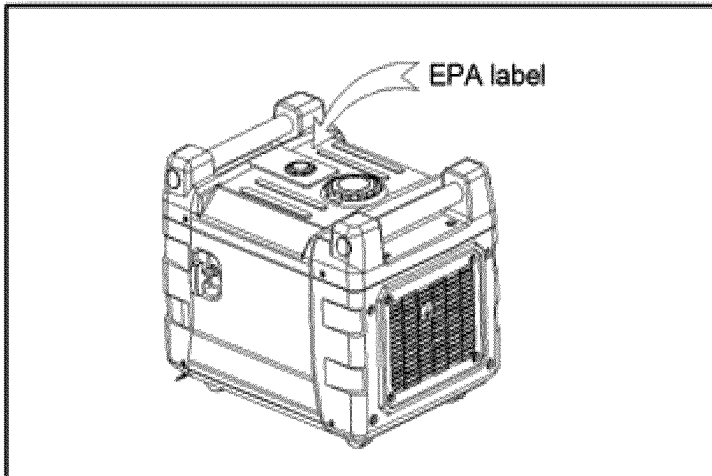
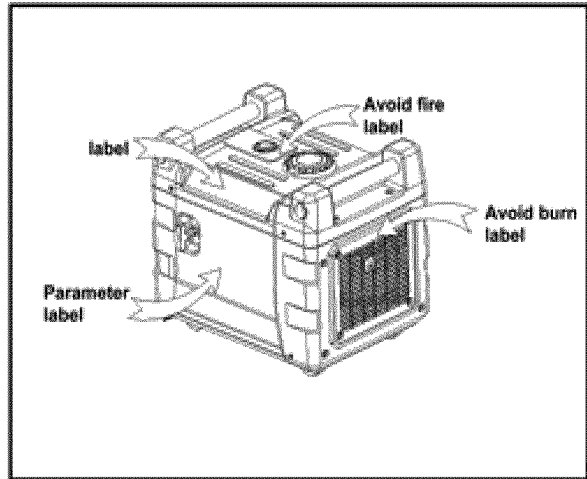
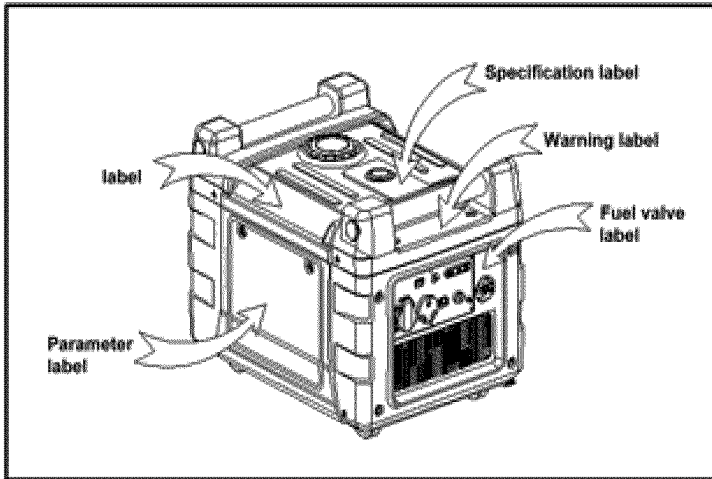



If the oil level is below the end of the dipstick, refill the recommended oil up to the top of the oil filler neck.

The Oil Alert System will automatically stop the engine before the oil level falls below the safe limit. However, to avoid the inconvenience of an unexpected shutdown, it is still advisable to visually inspect the oil level regularly.

4.1 Check engine oil level

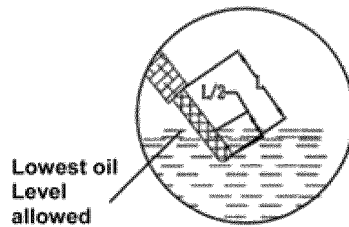
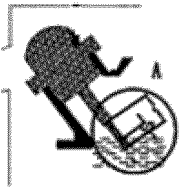
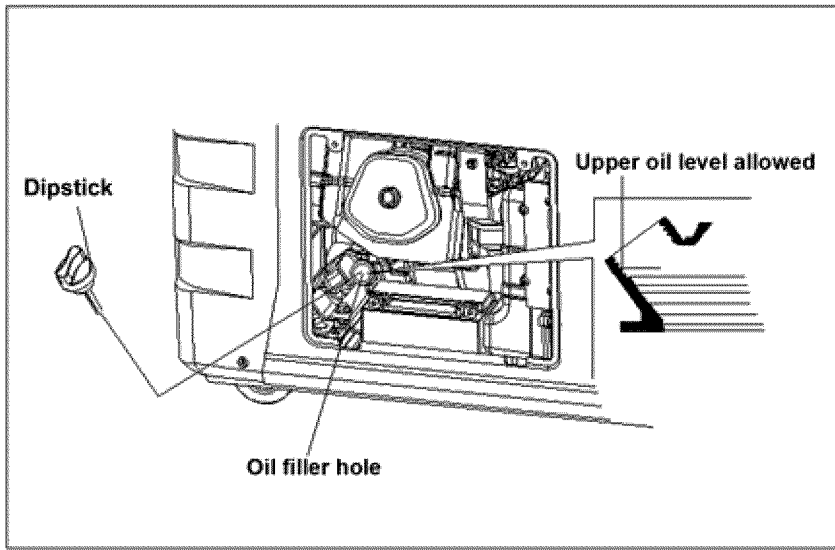

4.2 Check the fuel level

Tighten the fuel cap before transporting.

Use automotive fuel (Unleaded or low leaded is preferred to minimize combustion chamber deposits).

!! Don't use fuel-containing alcohol: Fuel system damage or engine performance problems resulting from the use of fuels that contain alcohol are not covered under the warranty.

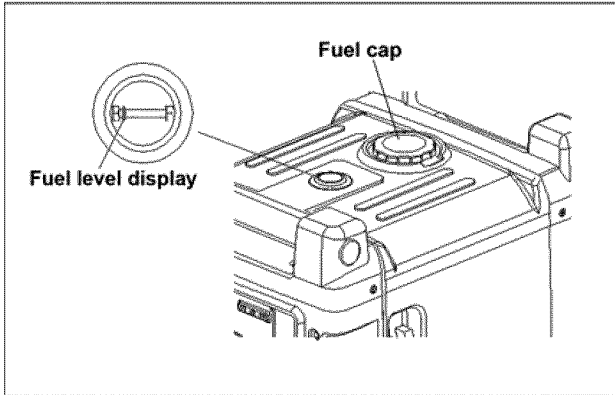

Never use an oil/gasoline mixture or dirty gasoline.
Avoid getting dirt, dust or water in the fuel tank.
After refueling, tighten the fuel filler cap securely.

Gasoline is extremely flammable and is explosive under certain conditions.
Refuel in a well-ventilated area with the engine stopped.

Do not smoke or allow flames or sparks in the area where the engine is refueled or where gasoline is stored.

Do not overfill the fuel tank. After refueling, make sure the tank cap is closed properly and securely.

Be careful not to spill fuel when refueling. Spilled fuel or fuel vapor may ignite. If any fuel is spilled, make sure the area is dry before starting the engine.

Avoid repeated or prolonged contact with skin or breathing of vapor. KEEP OUT OF REACH OF CHILDREN

4.3 Check the air cleaner.

Check the air cleaner element to be sure it is clean and in good condition.

1. Loosen the cover screw and remove the left side maintenance cover.
2. Press the latch tab on the top of the air cleaner body, remove the air cleaner cartridge, and check the element.
3. Clean or replace the element if necessary.

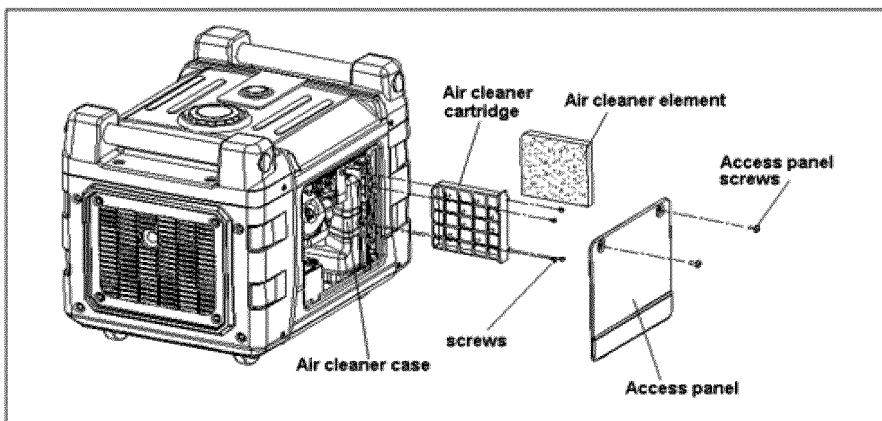

Never run the engine without the air cleaner. Rapid engine wear will result from contaminants. Such as dust and dirt, being drawn through the carburetor, into the engine.

It is normal for a little oil to appear under the air filter box if the generator is running for a long period of time, or a lot of oil is in the engine. Wipe up excess oil after each use and after stopping the generator.

5. GENERATOR USE

5.1 Starting the engine



Before starting the engine, disconnect any load from the DC receptacle.

1) Turn the fuel valve to "ON" position.

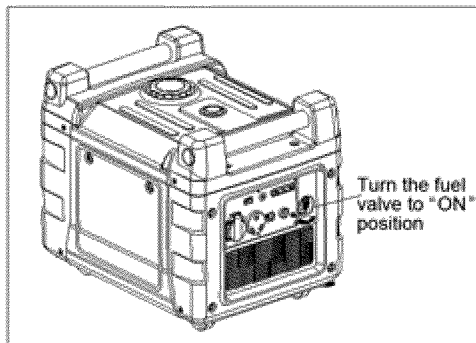

2) Put the electric start key into the engine switch, and turn it to the "ON" position.

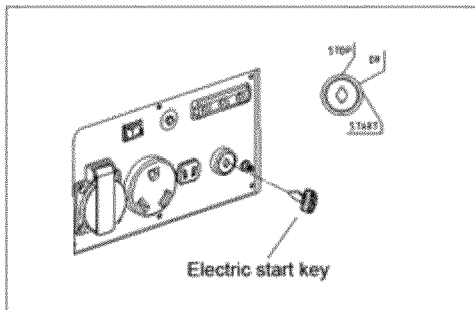

3) Turn the electric start key to "START" position until the engine has started.

Owner's Manual

The first time you start the engine, or restart the engine after a long period of time using the electric start and if the engine does not start. Check the battery. The battery might be drained. You can start the generator using the manual pull start.

Using the recoil start

1) Turn the fuel valve to the "ON" position.

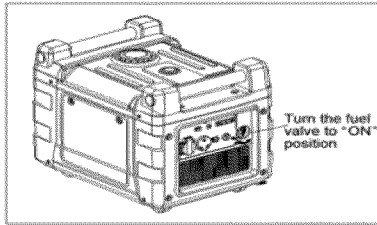

2) Put the electric start key into the engine switch, and turn it to the "ON" position.

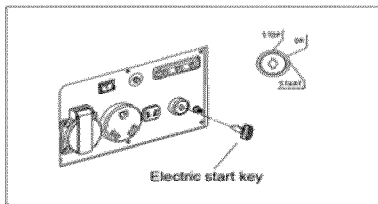

3) Pull the starting grip lightly until resistance is felt, then pull back briskly to start the engine

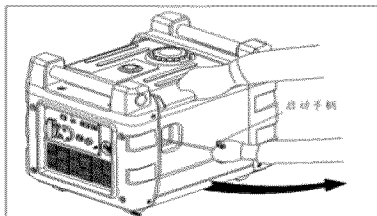

5.2 High altitude operation

At high altitude, the standard carburetor air-fuel mixture will be excessively rich. Performance will decrease, and fuel consumption will increase.

Even with suitable carburetor jetting, engine horsepower will decrease approximately 3.5% for each 300m (1,000 feet) increase in altitude.



Operation of the generator at lower altitude than the carburetor is jetted for may result in reduced performance, overheating, and serious engine damage caused by an excessively lean air/fuel mixture.

5.3 Generator use

5.3.1 WARNING!

- To prevent electrical shock from faulty appliances, the generator should be grounded. Connect an electric conductor (cable) of at least 1.5mm to 2mm between the generator's ground terminal and an external ground source.
- Connections for standby power to a building's electrical system must be made by a qualified electrician and must comply with all applicable laws and electrical codes. Improper connections can allow electrical current from the generator to back feed into the utility lines. Such back feed can cause damage or even electrocute once utility power is restored.
- Do not exceed the current limit specified for any one receptacle
- Do not connect the generator to a household circuit. This could cause damage to the generator or to electrical appliances in the house.
- Do not modify or use the generator for other purpose than it is intended for. Also observe the following when using the generator.
- Do not connect generators in parallel. —Do not connect an extension to exhaust pipe.

When an extension cable is required, be sure to use a shielded flexible cable,

Limit length of extension cables; 60m for cables of 1.5mm² and 100m for cables of 2.5mm².

Keep the generator away from other electric cables or wires such as distribution network.

The DC receptacle can be used while the AC power is in use. If you use both at the same time, be sure not to exceed the total power for AC and DC.

Most appliance motors require more than their rated wattage for start-up.

5.4 AC applications

1. Start the engine and make sure the output indicator light (green) illuminates.
2. Confirm that the appliance to be used is switched off, and plug in the appliance.

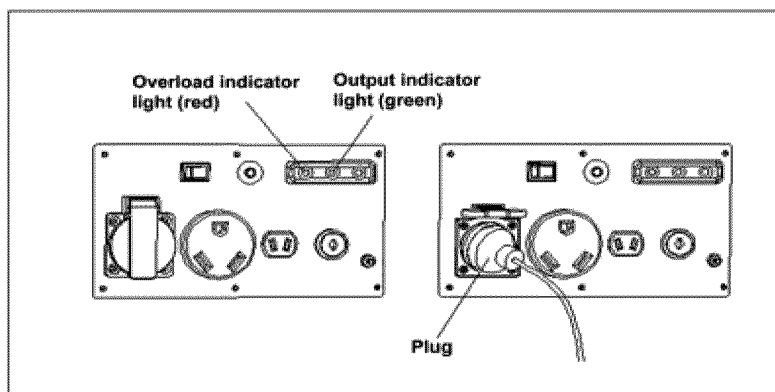

Substantial overloading that continuously lights the overload indicator light (red) may damage the generator. Marginal overloading that temporarily lights the overload indicator light (red) may shorten the service life of the generator.

Be sure that all appliances are in good working order before connecting them to the generator, if an appliance begins to operate abnormally, becomes sluggish, or stops suddenly, turn off the generator engine switch immediately. Then disconnect the appliance, and examine it for signs of malfunction.

5.5 Output and Overload indicators.

The output indicator light (green) will remain lighted during normal operating conditions.

If the generator is overloaded or if there is a short in the connected appliance, the output indicator light (green) will go OFF, the overload indicator light (red) will go ON and current to the connected appliance will be shut off.

Stop the engine if the overload indicator light (red) switches ON and investigate the overload source.



Before connecting an appliance to the generator, check that it is in good order, and that its electrical rating does not exceed that of the generator. Then connect the power cord of the appliance, and start the engine.

Be sure all equipment is turned off before plugging in the power cord.

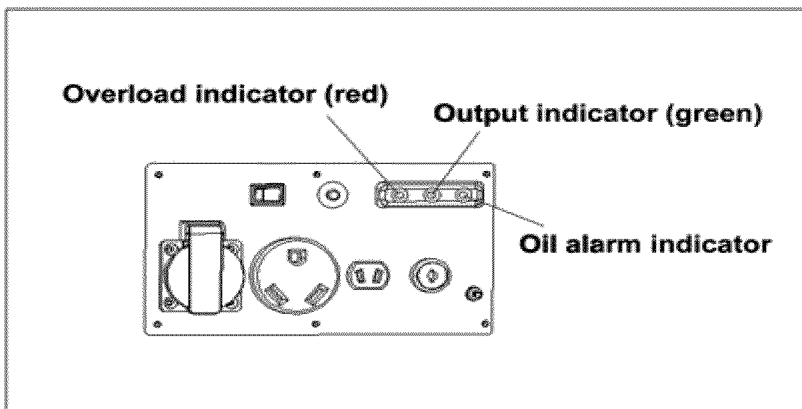

When an electric motor is started, both the overload indicator lights (red) and the output indicator light (green) may go on simultaneously. This is normal if the overload indicator light (red) goes off after about four seconds.

If the overload indicator light (red) stays on, consult your dealer.

Connect the ground terminal.

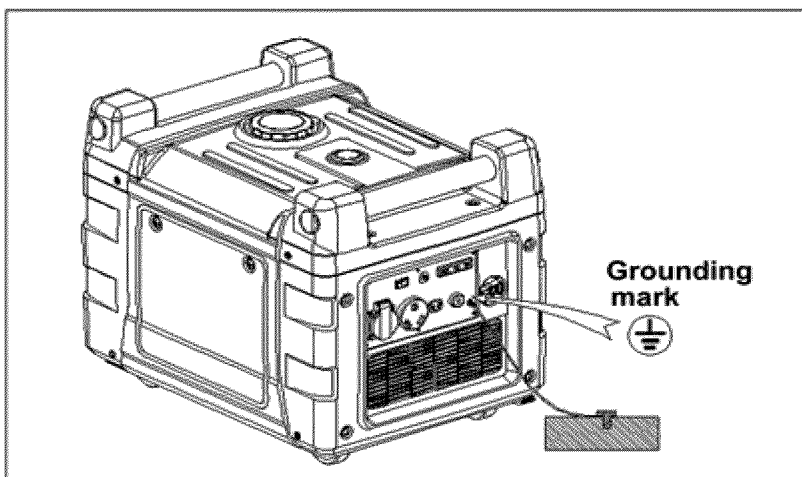

Start engine according to "STARTING THE ENGINE" section.

Owner's Manual



When the output indicator light (green) does not light and the overload indicator light (red) lights instead, set the engine switch to STOP, stop the engine at once and then start the engine again.

3. Confirm that the equipment to be used is switched off, and insert the plug of the equipment to be used into the AC receptacle unit A.



Check that the equipment to be connected is switch off. When the equipment to be used is switched on, it will operate suddenly, and injuries or accidents may be caused.

4. Switch on the equipment, output indicator light will be ON. In case of overload operation or when trouble occurs for the equipment being used, the output indicator light (green) will go out, the overload indicator light (red) will light continuously, and no power will be put out. At this time, the engine will not stop, so that the engine must be stopped by setting the respective engine switch to STOP.

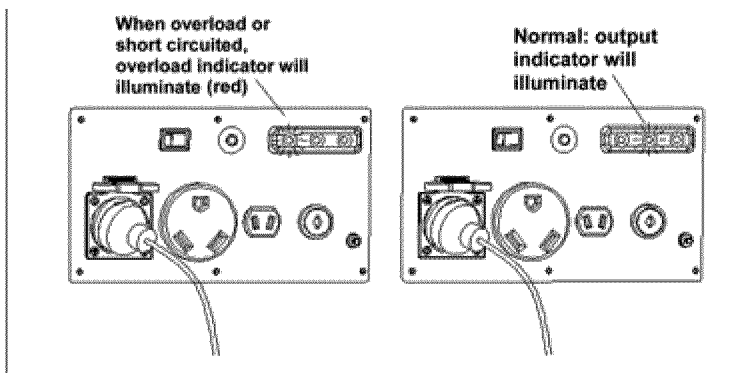

When equipment requires a large starting power, the overload indicator lights (red) and the output indicator light (green) may light together for a short time, but this is no abnormality. After start of the equipment, the overload indicator light (red) will go out and the output indicator light (green) will stay lit.

| AC | Electric lamps | Power tools | Electromotor | DC battery |
|--------------|----------------|-------------|--------------------------|---|
| Power factor | 1 | 0.8-0.9 | 0.4-0.7(efficiency 0.86) | |
| GG3500D | 0-3000W | 0-2400W | 0-1800w | Rated voltage 12v Rated current 6A (Canada) 8.3A(except Canada) |

5.6 DC applications

For charging 12V automotive batteries:

The generator cannot sense a sensibility load with the same power, which the manual indicates. It only can sense 40%-70% power, which the manual indicates.

Owner's Manual

| | Loading voltage (V) | Loading voltage (V) | Loading current (A) |
|----------------------------|---------------------|---------------------|---------------------|
| Opening the smart throttle | 22 | 12 | 6 |
| Closing the smart throttle | 27 | 13 | 8.5 |
| DC Max. Output power | 37 | 13.5 | 8.5 |

The generator cannot sense a sensibility load with the same power which the manual indicates. It only can sense 40%-70% power which the manual indicates.

Example:

| | | |
|------------------------|--------------|-----------------|
| Model | | GG3500D |
| Generator rated output | | 3.0 KVA |
| Frequency | Power factor | |
| | 1.0 | 3500 W |
| | 0.4-0.75 | 0-1400W~2625W |
| DC | | 100W (12V/8.3A) |

- When using the DC output, turn Smart Throttle to the OFF position. The DC current will be below 5A if turning on the Smart Throttle without AC current output.
- When charging batteries, person must be present to monitor the voltage. Stop charging when the voltage of the batteries is above 16V. Or it may cause battery explosion, resulting in serious injury or death.

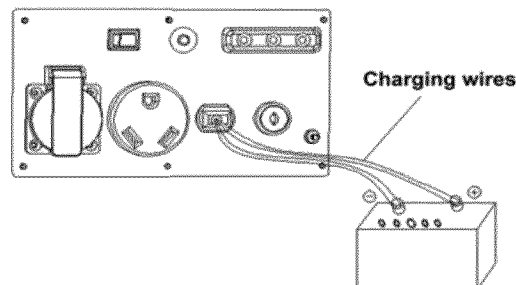

- To prevent the possibility of creating a spark near the battery, connect charging cable first to the generator, then to the battery. Disconnect cable first at the battery.
- Before connecting charging cables to a battery that is installed in a vehicle, disconnect the vehicles grounded battery cable. Reconnect the vehicle's grounded battery cable after the charging cables are removed. This procedure will prevent the possibility of short circuit and sparks if you make accidental contact between a battery terminal and the vehicle's frame or body.
- Do not attempt to start an automobile engine while the generator still connected to the battery. The generator may be damaged.
- Connect the positive battery terminal to the positive charging cord. Do not reverse the charging cables, or serious damage to the generator and/or the battery may occur.
- The battery gives off explosive gases; Keep spark, flames and cigarettes away. Provide adequate ventilation when charging.
- The battery contains acid (electrolyte). Contact with skin or eyes may cause severe burns. Wear protective clothing and a face shield.

If battery acid gets on your skin, flush with water.

If battery acid gets in your eyes, flush with water for at least 15 minutes and call a physician.

If swallowed, drink large quantities of water or milk and follow with milk of magnesia or vegetable oil and call a physician.

- KEEP OUT OF THE REACH OF CHILDREN, PETS AND UNTRAINED PEOPLE.

5.7 Start the engine

- The DC receptacle may be used while the AC power is in use.
- An overloaded DC circuit will trip the DC circuit protector. If this happens, disconnect the DC load before resetting circuit protector to resume operation.

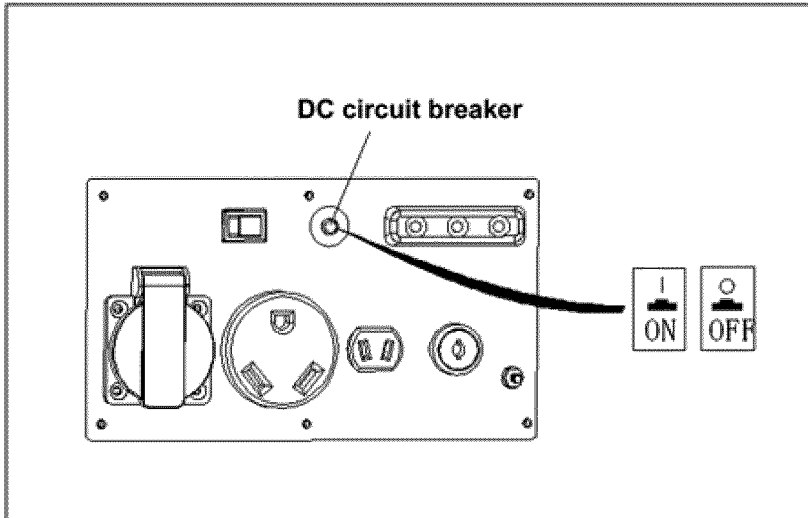

5.8 Oil alert system

- The oil alert system is designed to prevent engine damage caused by insufficient amount of oil in alert system will automatically shut down the engine (the engine switch will remain in the ON position).
- If the oil alert system shuts down the engine, the oil alert indicator light (red) will come on when you operate the starter, and the engine will not run. If this occurs, add engine oil.

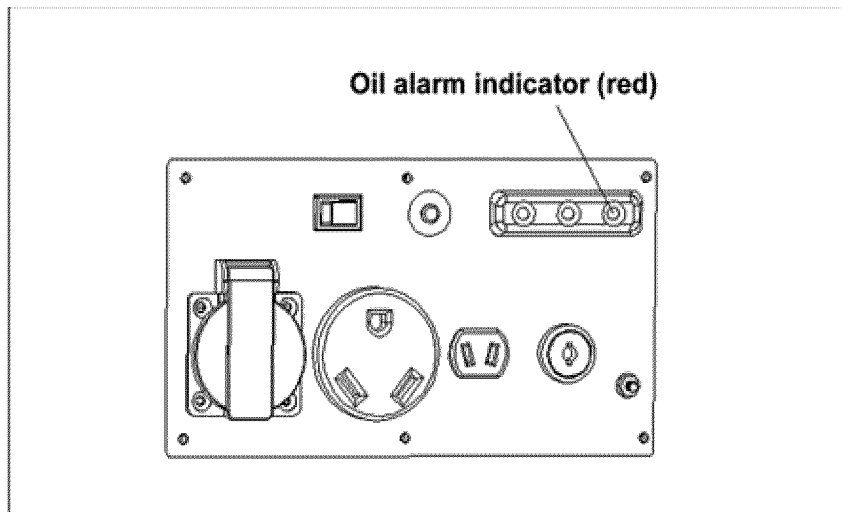

5.9 Stopping the engine

To stop the engine in an emergency, turn the engine switch to the OFF position.

In normal use:

1. Switch off the connected equipment and pull the inserted plug out.

Owner's Manual

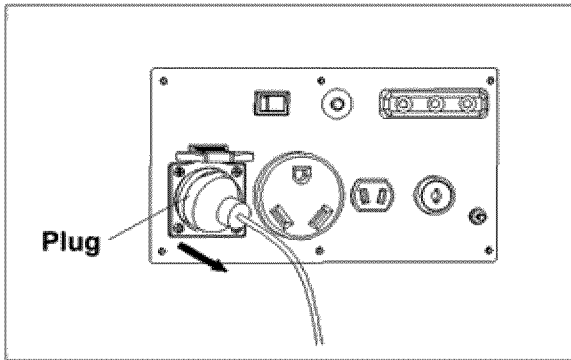

2. Turn the engine switch to the OFF position

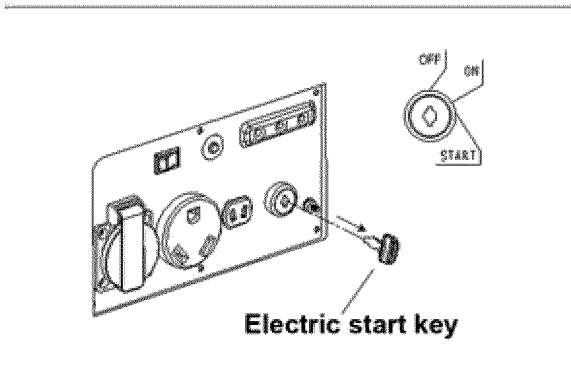

3. Turn the fuel valve to "OFF" position.

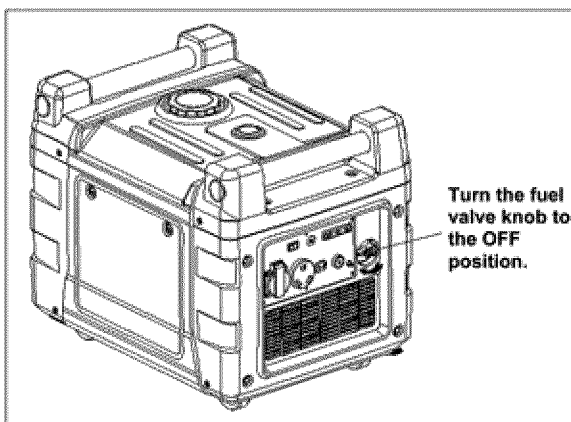

Be sure to tighten the fuel cap and the engine switch is in the "OFF" position when stopping, transporting and/or storing the generator.

Owner's Manual

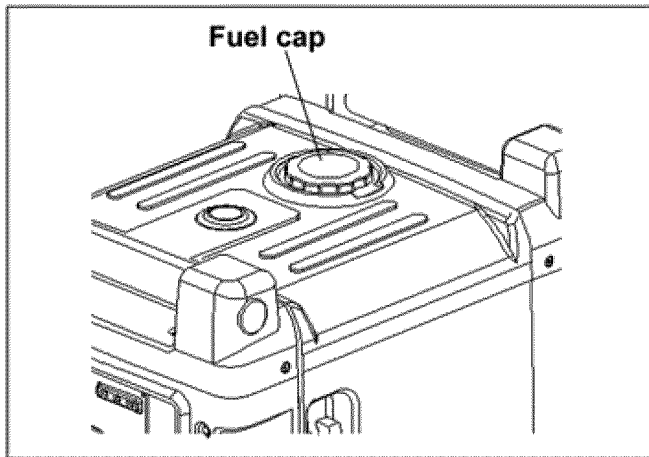

6 MAINTENANCE

- The purpose of the maintenance and adjustment schedule is to keep the generator in the best operating condition.
- Inspect or service as scheduled in the table below.



Shut off the engine before performing any maintenance, If the engine must be running, make sure the area is well ventilated. The exhaust contains poisonous carbon monoxide gas.



Use authorized parts or their equivalent .The use of replacement parts which are not of equivalent quality may damage the generator.

Maintenance schedule

| | | Each use | Each month or 20 Hrs. | Each 3 months or 50 Hrs. | Each 6 months or 100 Hrs. | Each year or 200 Hrs |
|---------------------------|-------------------|---|--------------------------|-----------------------------|------------------------------|----------------------------|
| | Check | ■ | | | | |
| | Replace | | ■ | | ■ | |
| | Check | | | ■ | | |
| | Replace | | | ■ | | |
| Spark plug | Clean & Adjust | | | | ■ | |
| Combustion chamber | Clean | | | | ■ | |
| Valve clearance | Check & Adjust | | | | | ■ |
| Fuel tank and filter tank | Clean | | | | | ■ |
| Fuel line | Check | Every 2 years (replace if necessary as (3) | | | | |

NOTE: (1) Log hours of operation to determine proper maintenance.

(2) Service more frequently when used in dusty areas.

(3) These items should be serviced by an authorized dealer, unless the owner has the proper tools and is mechanically proficient. See the Shop Manual.

| Temperature (°) | Time for changing oil (hour) | Recommended power factor |
|-----------------|------------------------------|--------------------------|
| .25 | Normal | 100% |
| 30 | 18 | 95% |
| 35 | 15 | 85% |
| 40 | 12 | 70% |

WARNING! If the temperature of external environment reaches or higher than 45°, the generator sets should be stopped working, otherwise, the generator sets will be damaged.

WARNING! If the temperature of external environment reaches or lower than -5°, the generator sets can not be started.

6.1 Changing oil

Drain the oil while the engine is still warm to assure rapid and complete draining.



Make sure to turn the engine switch and the fuel cap vent lever OFF before draining.

1. Lean the generator.
2. Fasten the oil lead pipe on the oil drain plug as the picture. Then drain out the oil.
3. Refill the new oil and check the oil position in the crankcase.
4. After refilling the new oil into the crankcase, move the generator from left to right to make sure the bobber of the oil alarm system is floating.

Engine oil capacities: 1.0 L

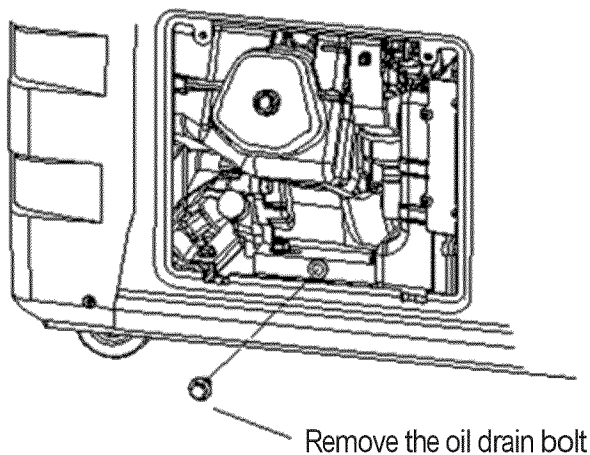

Refill Oil

1 Refill oil

1. Remove the screws and open the access panel.
2. Revolve out the dipstick.
3. Revolve the oil filling pipe into the oil filler hole.
4. Use the oil filling bottle pour the oil into the crankcase and check the oil level.

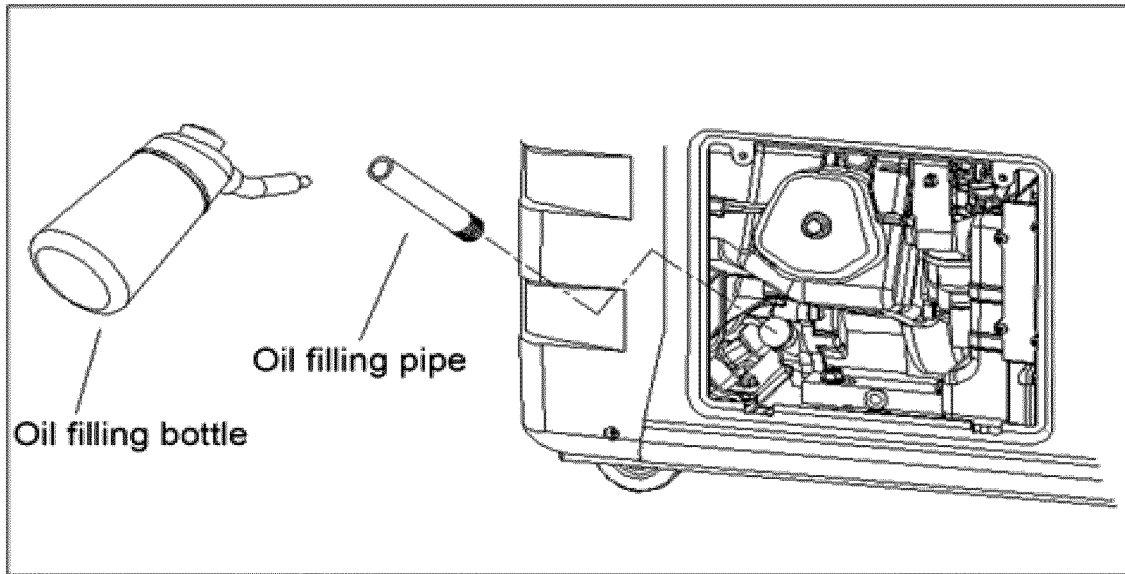

After refill the new oil into the crank case, PLS shake the generator left to right some times and make sure the bobber of the oil alarm system is floating.

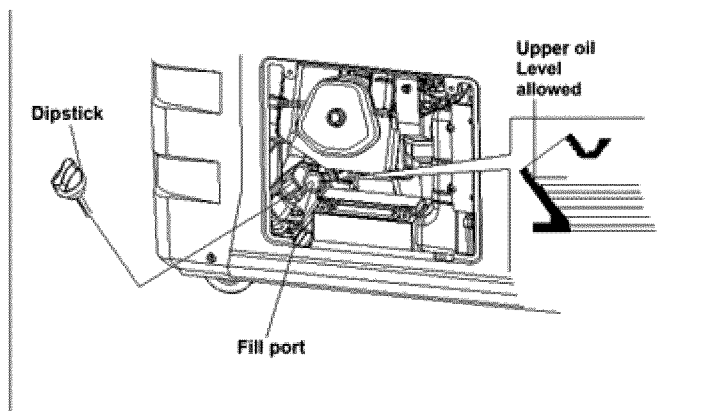

 Please dispose of used motor oil in a manner that is compatible with the environment. We suggest you take it in a sealed container to your local service station for reclamation. Do not throw it in the trash or pour it on the ground.

6.2 Air cleaner service

A dirty air cleaner will restrict airflow to carburetor. To prevent carburetor malfunction, Service the air cleaner regularly. Service more frequently when operating the generator in extremely dirty areas.



Do not use gasoline or low flash point solvents for cleaning. They are flammable and explosive under certain conditions.

Loosen the cover screw and remove the access panel.

Remove the screw under the air filter case.

Pull the air filter cartridge down 1.181 inches and remove the air filter cartridge.

Remove the air filter iron clip and check the air filter element. Clean or replace the element if necessary.

Reinstall the air filter parts after cleaning or replacing air filter element.

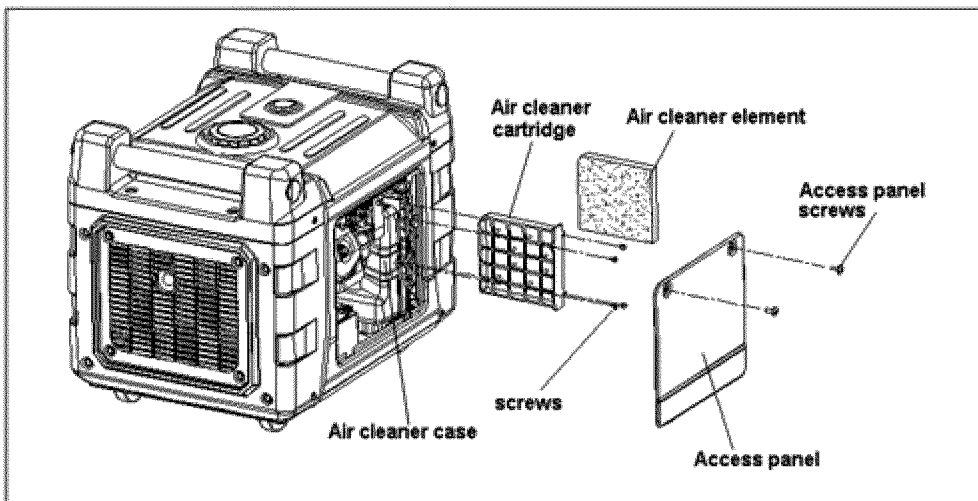

6.3 Spark plug servicing

Please use high quality authentic spark plug.

To ensure proper engine operation, the spark plug must be properly gapped and free of deposits.

1. Remove the screws and the maintenance cover

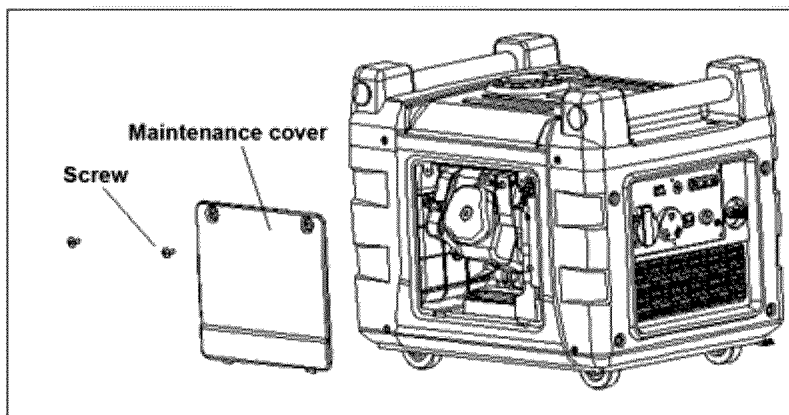

2. Take out the ignition coil rubber boot.

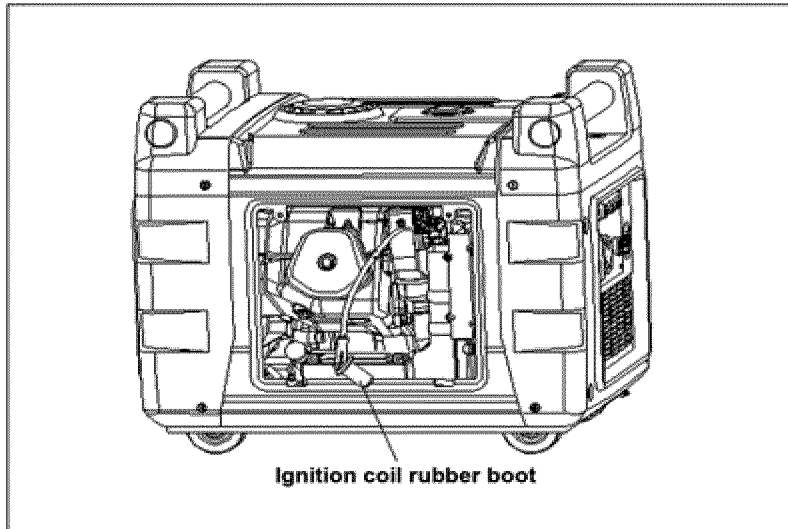

Remove the spark plug with spark plug wrench.

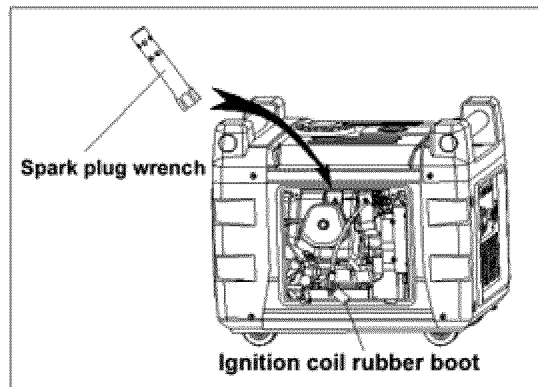
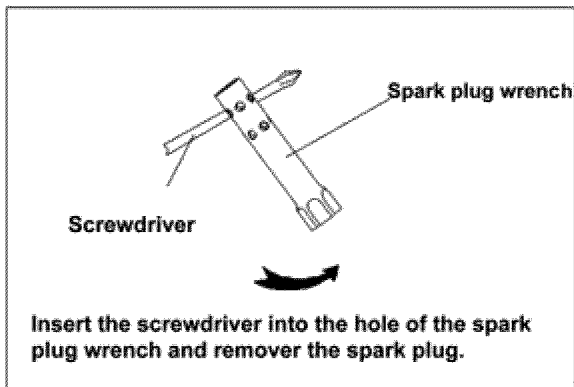

Visually inspect the spark plug. Discard it if the insulator is cracked or chipped. Clean spark plug with a wire brush if it is to be reused.

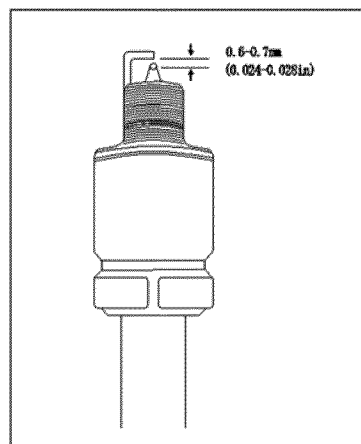

5. Install the spark plug carefully by hand, to avoid cross threading.
6. After a new spark plug has been seated by hand, it should be tightened 1/2 turn with a wrench to compress its washer. If a used plug is being reinstalled, it should only require 1/8 to 1/4 turns after being seated.
7. Reinstall the ignition coil rubber boot on the spark plug securely.
8. Reinstall the controlling panel.



The spark plug must be securely tightened. An improperly tightened plug can become very hot and possibly damage the generator.

Never use a spark plug with an improper heat range.

Never use a spark plug without damping resistance, or it will cause no AC output.

SPARK ARRESTOR AND MUFFLER SERVICE

A dirty muffler will make big noise and affect the engine.

Clean and maintain the spark arrestor timely.

The spark arrestor of the muffler needs to be cleaned frequently if you use the generator in very dirty conditions, or replace the spark arrestor if necessary.



CAREFUL!

- Before clean the spark arrestor of muffler make sure the generator is OFF.
- Before performing maintenance of the spark arrestor of muffler, make sure the machine is cooling, otherwise, it will cause scald by the hot muffler.

1. Remove the M6 screws and open the muffler cover.
2. Remove two M4 screws on the spark arrestor.
3. Take down the spark arrestor as per the following figure.
4. Check the spark arrestor, clean or replace it if necessary.

Maintenance

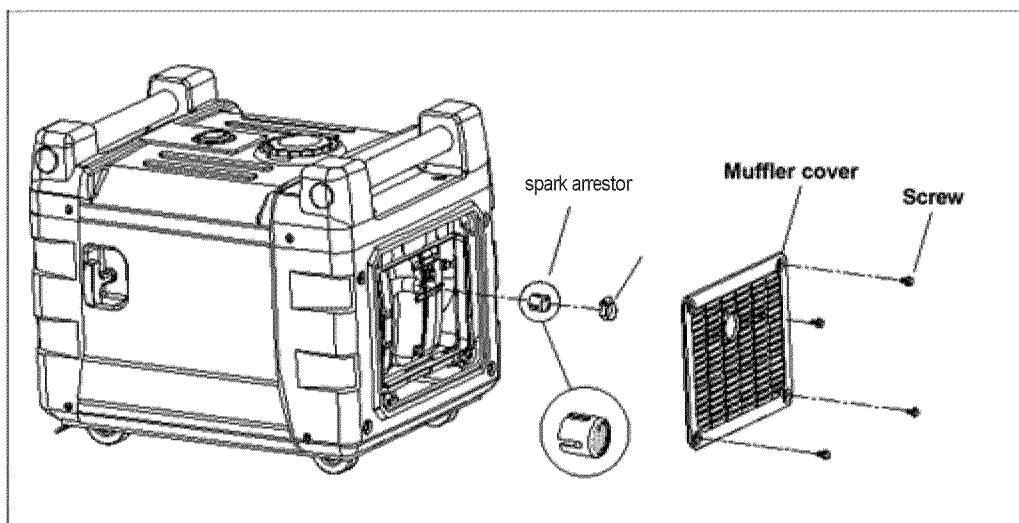

7 TRANSPORTING AND STORAGE

To prevent fuel spillage when transporting or during temporary storage, the generator should be secured upright in its normal operating position, with the engine switch OFF.

The fuel cap vent lever is turned counter clockwise to the OFF position.

Allow the engine to cool well before turning the fuel cap vent lever to the OFF position,

7.1 When transporting generator:

- Do not overfill the tank. (There should be no fuel in the filler neck).
- Do not operate generators while it is on a vehicle. Take the generator off the vehicle and use it in a well-ventilated place.
- Avoid a place exposed to direct sunlight when putting the generator on a vehicle. If the generator is left in an enclosed vehicle for many hours, high temperature inside the vehicle could cause fuel to vaporize resulting in a possible explosion.
- Do not drive on a rough road for an extended period with the generator on board. If you must transport the generator on board. If you must transport the generator on a rough road, drain the fuel from the generator before hand.

7.2 Before storing the unit for an extended period:

1. Be sure the storage area is free of excessive humidity and dust.
2. Drain the fuel.



Gasoline is extremely flammable and explosive under certain conditions.
Do not smoke or allow flames or sparks in the area.

2. Completely drain the fuel from the tank. Open the fuel valve, start the engine and operate it in the idle position until all remaining fuel is gone and the engine stops automatically.

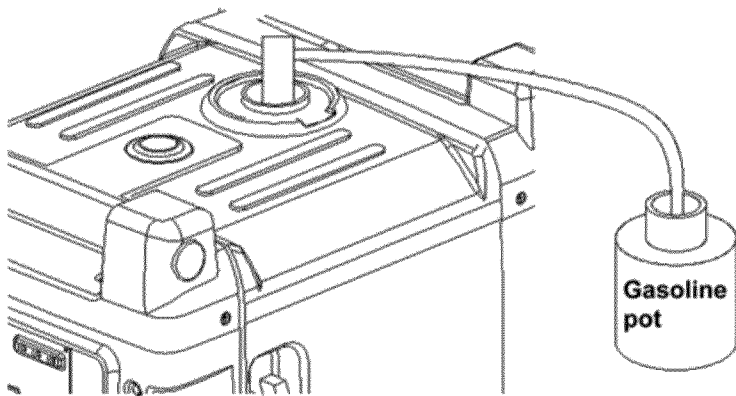

4. Drain oil.

5. Remove spark plug and fill cylinder with 2cc's fresh oil. Pull start motor 3-4 times to discharge the remaining oil. Then reinstall the spark plug.

6. Pull the starting cord slowly until resistance is strong. At this time, the piston is moving to the top of the compression stroke and the valves will be closed.

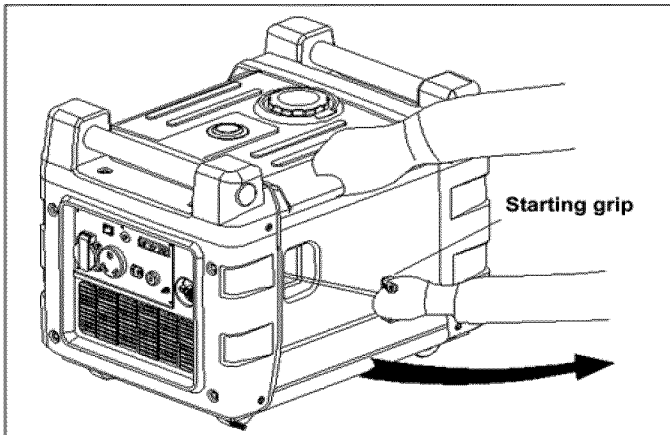

8 TROUBLESHOOTING

Engine will not start:

- Check fuel level
- Is the engine switch and fuel valve “on”? Turn them to the “on” position
- Enough lubricating oil? Add recommended oil if necessary.
- Is there fuel in the carburetor?
- Spark plug works or not? Replace spark plug

Send the generator to an authorized service dealer if the generator still does not start or call 866-896-6881 toll free

- Shake the generator several times to make the float rise if the generator cannot start after adding oil for the first time and the oil alarm indicator stays on when pulling the starting grip.
- Make sure there is no spilled fuel around the spark plug. Spilled fuel may ignite.
- If the engine still doesn't start, have the generator repaired by a licensed repair person.

INSPECTION:

1. Remove the spark plug rubber boot and clean any dirt from around the spark plug
2. Remove the spark plug and place it in the spark plug rubber boot.
3. Connect the side electrode of the spark plug to the metal parts of the engine.
4. Pull the starting cord. A spark could jump across the gap.

Owner's Manual

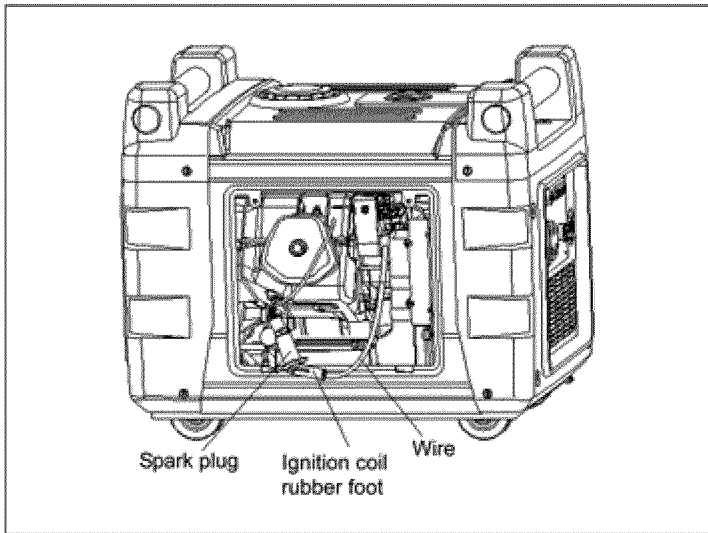

The equipment that connects to the generator does not start:

- Is the output indicator on?
- Is the overload indicator on? No (Bring the generator to an authorized dealer.)
- Does the electrical equipment work when plugged directly? No Restart after turning off the overload indicator.

(Bring the generator to an authorized dealer.)

There is no power in the DC electric outlet.

- Is there electric circuit breaker intact? Replace the electric circuit breaker
- Check air filter. If dirty clean or replace air filter element
- Check spark arrestor. If dirty clean or replace
- Check if gasoline is bad or old. If so replace gasoline

Owner's Manual

Specification

9.1 Size and weight

| | |
|-------------------|---------------------|
| Type | GG35000D |
| L x W x H | 23.6 x 17.7 x 19.68 |
| Net weight kg/lbs | 50/110 |

9.2 Engine

| | |
|-------------------------|-------------------------|
| Type | 4-stroke OHV 1-Cylinder |
| Displacement | 269cc/357cc |
| Compression ratio | 9.2:1 |
| Engine speed | 2200~ 3600 rpm |
| Cooling system | Forced air |
| cooling Ignition system | T.D.I |
| Oil capacity (L) | 1.0 |
| Fuel tank capacity (L) | 14 |
| Spark plug | NGK |
| Noise level(7m away) | 59 dB(A) |
| Continuous operation | 5.5h |

9.3 Generator

| | | |
|-----------|----------------------|---------|
| AC OUTPUT | Rated voltage (V) | 120/24 |
| | Rated frequency (Hz) | 50/60 |
| | Rated current (A) | 25/12.5 |
| | Rated output (KVA) | 3.5 |
| DC OUTPUT | Rated voltage (V) | 12 |
| | Rated current (A) | 8.3 |

WIRING DIAGRAM

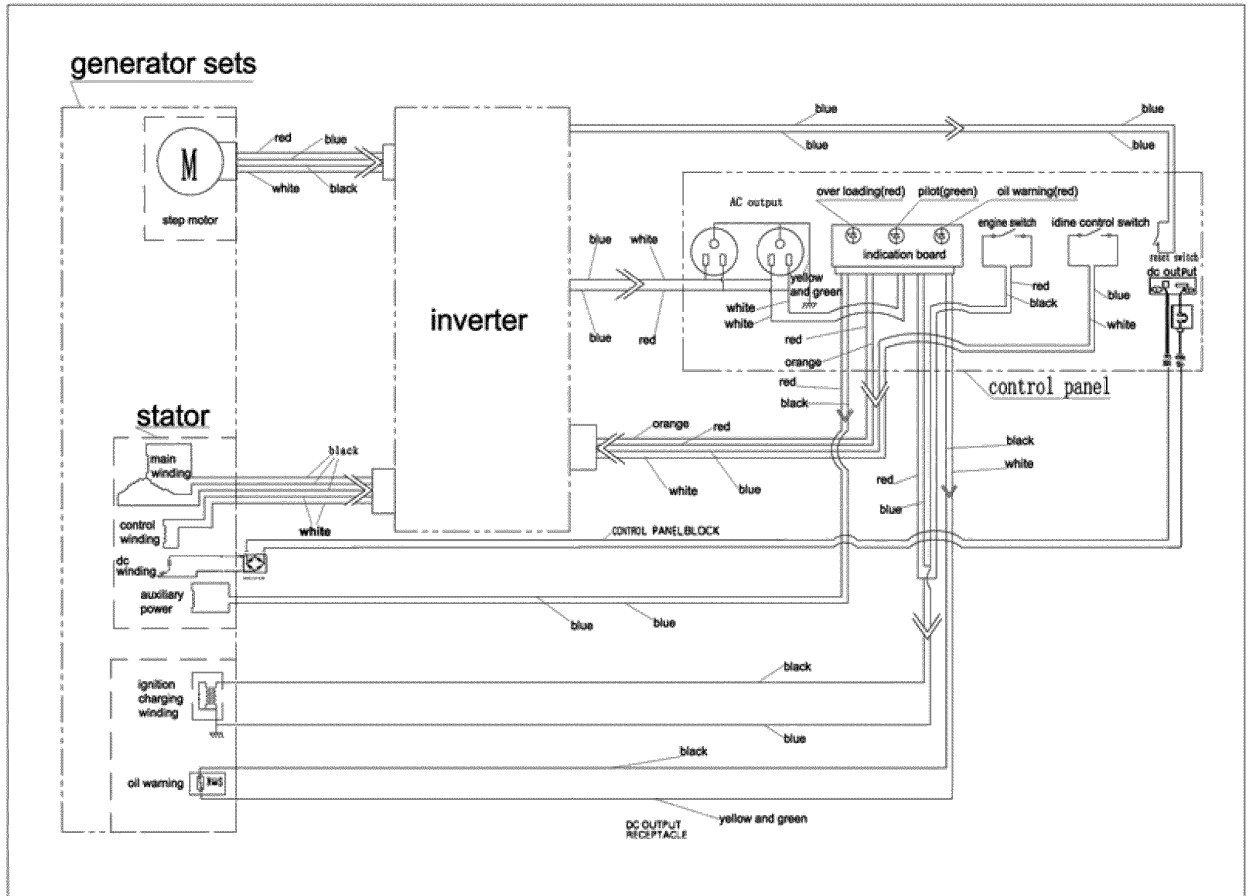

PARTS DIAGRAM

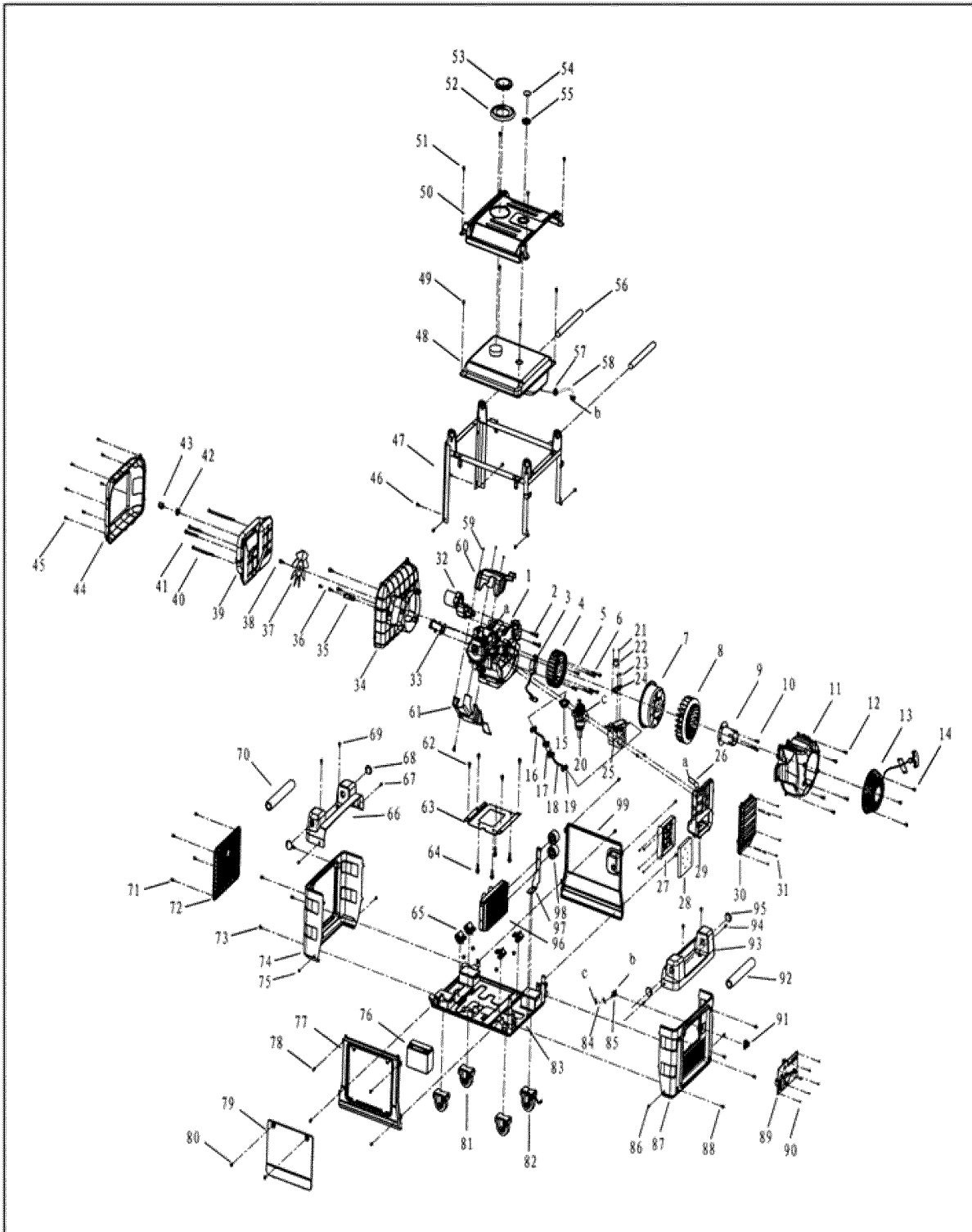

Owner's Manual

PARTS LIST

| NO. | Parts Description | NO. | Parts Description |
|-----|---|-----|--------------------------------|
| 1. | Engine Assembly | 50 | Top cover |
| 2. | M8 X 40 Bolt | 51 | M6 X 12 Bolt |
| 3. | Ignition Coil | 52 | Fuel tank sleeve |
| 4. | Stator Assembly | 53 | Fuel cap |
| 5. | M6 X 25 Bolt | 54 | Fuel level display cover board |
| 6. | M6 X50 Inner 6 Cornus Bolt | 55 | Fuel level display sleeve |
| 7. | Rotor Assembly | 56 | Handle |
| 8. | Flywheel Fan | 57 | Sheet iron clip |
| 9. | Starter Cup | 58 | Connection Pipe, fuel tank |
| 10. | M6 X 20 Bolt | 59 | M4.2 x10 self-tapping screw |
| 11. | Motor Recoil Cover | 60 | Upper fan cover |
| 12. | M6 X 18 Bolt | 61 | Lower fan cover |
| 13. | Recoil Starter Assembly | 62 | M8 x15 bolt |
| 14. | M6 X 10 Bolt | 63 | Engine Bracket |
| 15. | Carburetor Gasket, Plastic | 64 | M10 x 30bolt |
| 16. | Connection Pipe for Carburetor Gasket, Plastic | 65 | Absorber |
| 17. | Backpressure Valve | 66 | Rear cover |
| 18. | Connection Pipe for Choke | 67 | M6 x12plate screw |
| 19. | Steel Wire Clip | 68 | Handle stopple |
| 20. | Carburetor | 69 | M6 x12 bolt |
| 21. | M3 X 8 Obtuse Screw | 70 | Handle spongs sleeve |
| 22. | Step Motor | 71 | M6 x12 bolt |
| 23. | M5 X 8 Plate Screw | 72 | Exhaust cover |
| 24. | Step Motor, Base | 73 | M6 x12 bolt |
| 25. | Throttle frame | 74 | Rear housing |
| 26. | Breath Pipe | 75 | M6 x12plate screw |
| 27. | Air Cleaner cartridge | 76 | Battery |
| 28. | Air Cleaner element | 77 | Lift side board |
| 29. | Air Cleaner case | 78 | M6 x12 bolt |
| 30. | Air Cleaner Cover | 79 | Maintenance cover |
| 31. | M4. 2 X 12 Self-tapping Screw | 80 | M6x12 big head bolt |
| 32. | Starting Motor | 81 | Common wheels |
| 33. | Muffler Bent Tube | 82 | Wheels with brake |
| 34. | Muffler Cover | 83 | Chassis |
| 35. | Muffler Cover Frame, Firmed Frame | 84 | Carburetor connetion pipe |
| 36. | M6 X 12 Bolt | 85 | Fuel valve |
| 37. | Fan | 86 | M6 x12 plate screw |
| 38. | M10 X 20 Bolt | 87 | Front Housing |
| 39. | Muffler Assembly | 88 | M6 x12 bolt |
| 40. | M8 X 165 Bolt | 89 | Control panel assembly |
| 41. | M8 X 85 Bolt | 90 | M4.2 x10 self-tapping screw |
| | | 91 | Fuel valve knob |

Owner's Manual

| | | | |
|-----|---------------------|----|----------------------|
| 42. | Clip | 92 | Handle spongs sleeve |
| 43. | Spark Arrestor | 93 | Front cover |
| 44. | Muffler Cover | 94 | M6 x12 plate screw |
| 45. | M6 X 16 Plate Screw | 95 | Handle stopple |
| 46. | M6 X 12 Bolt | 96 | Inverter assembly |
| 47. | Frame | 97 | inverter bracket |
| 48. | Fuel tank | 98 | Inductance |
| 49. | M6 X 12 Bolt | 99 | Right side board |