

⚠ DANGER
Carbon Monoxide

Using a generator indoors WILL KILL YOU IN MINUTES.

Carbon Monoxide

Generator exhaust contains high levels of carbon monoxide (CO), a poisonous gas you cannot see or smell. If you can smell the generator exhaust, you are breathing CO. But even if you cannot smell the exhaust, you could be breathing CO.

- NEVER use a generator inside homes, garages, crawlspaces, or other partly enclosed areas. Deadly levels of carbon monoxide can build up in these areas. Using a fan or opening windows and doors does NOT supply enough fresh air.
- ONLY use a generator outdoors and far away from open windows, doors, and vents. These openings can pull in generator exhaust.

Even when you use a generator correctly, CO may leak into the home. ALWAYS use a battery-powered or battery-backup CO alarm in the home.

If you start to feel sick, dizzy, or weak after the generator has been running, move to fresh air RIGHT AWAY. See a doctor. You could have carbon monoxide poisoning.

GENTRON®

Owner's Manual
**2000W DIGITAL
GENERATOR**



Please read and save these instructions.

**HAVE QUESTIONS OR NEED SERVICE
DO NOT RETURN TO STORE!** 
PLEASE CALL TOLL FREE: 888.896.6881

www.GentronUSA.com

- Thank you for purchasing a generator.
- This manual covers operation and maintenance of the generator.
- Reserves the right to make changes at anytime without notice and without taking any obligation.
This publication can't be reproduced without written permission.
- Pay special attention to the following words:
- If a problem should arise or if you have any questions, consult an authorized dealer.

⚠ WARNING Generator is designed to give safe and dependable service if operated according to instructions. Read the Owner's Manual before operating the generator. Failure to do so could result in personal injury or equipment damage.

CATALOG

① SAFETY INSTRUCTIONS	02
② COMPONENT IDENTIFICATION	05
③ PRE-OPERATION CHECK	07
④ STARTING THE ENGINE	10
⑤ GENERATOR USE	12
⑥ STOPPING THE ENGINE	16
⑦ MAINTENANCE TIPS & INSTRUCTIONS	18
⑧ TRANSPORTING/STORAGE	24
⑨ TROUBLESHOOTING (FAQS)	25
⑩ SPECIFICATIONS	28

1. SAFETY INSTRUCTIONS



- Generator is designed to give safe and dependable service if operated according to instructions.
Read the Owner's Manual before operating the generator.
Failure to do so could result in personal injury or equipment damage.



- Exhaust gas is poisonous. Never run the generator in an enclosed area.
Be sure to provide adequate ventilation.



- Stop the engine before refueling
- Gasoline is extremely flammable and explosive under certain conditions, Refuel in a ventilated area.
- Keep away from cigarette, smoke and sparks when refueling.
Always refuel in a well-ventilated location.
- Wipe up spilled gasoline.



- The muffler becomes very hot during operation and remains hot for a while after stopping the engine.
Do not touch the muffler while it is hot.
Let the engine cool down before moving the generator.
(Pay attention to the warning marks attached to the generator.)



- Connections from standby power to a building's electrical system must be made by a qualified electrician and must comply with all applicable laws and electrical codes

! WARNING

- Always make a pre-operation inspection (page 8) before you start the engine.
- Place the generator at least 1 m (3 ft) away from buildings or other equipment during operation.
- Operate the generator on a level surface.
If the generator is tilted, fuel spillage may result.
- Know how to stop the generator quickly and understand operation of all the controls. Never operate the generator without proper instructions.
- Keep children and pets away from the generator when it is in operation.
- Keep away from rotating parts while the generator is running.
- Do not operate the generator in rain or snow and do not let it get wet.

2. COMPONENT IDENTIFICATION

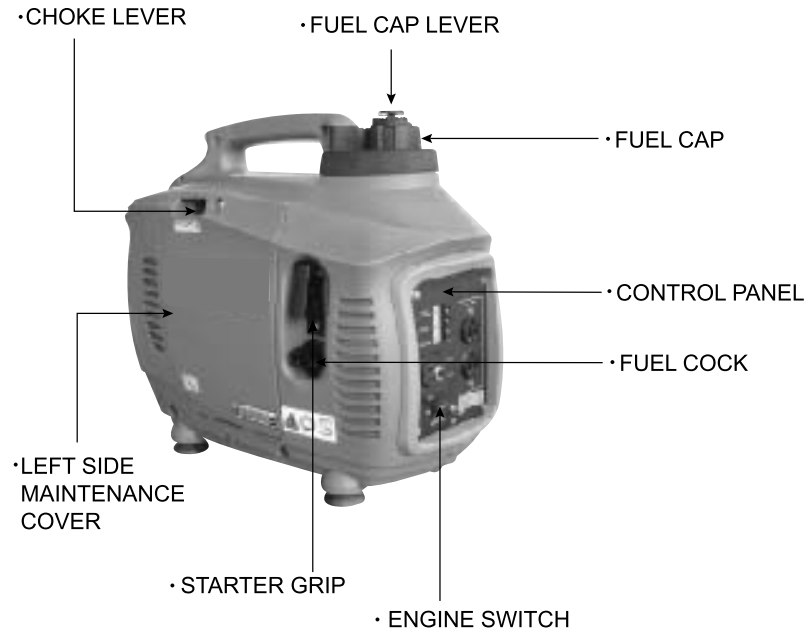

CONTROL PANEL

- OIL ALERT INDICATOR LIGHT
- OUTPUT INDICATOR LIGHT
- OVERLOAD INDICATOR LIGHT
- DC RECEPTACLE
- DC CIRCUIT PROTECTOR

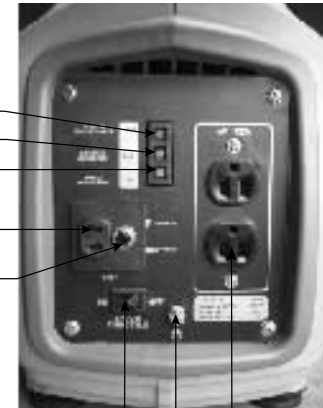

- ENGINE SWITCH
- Ground
- AC Receptacle



3. PRE-OPERATION CHECK

① Check oil level.

Loosen the cover screw and remove the left side maintenance cover.
Remove the oil filler cap, and wipe the dipstick with a clean rag. Check the oil level by inserting the dipstick in the filler hole without screwing it in.
If the oil level is below the end of the dipstick, refill with recommended oil (SAE 10W-30/0.5L)

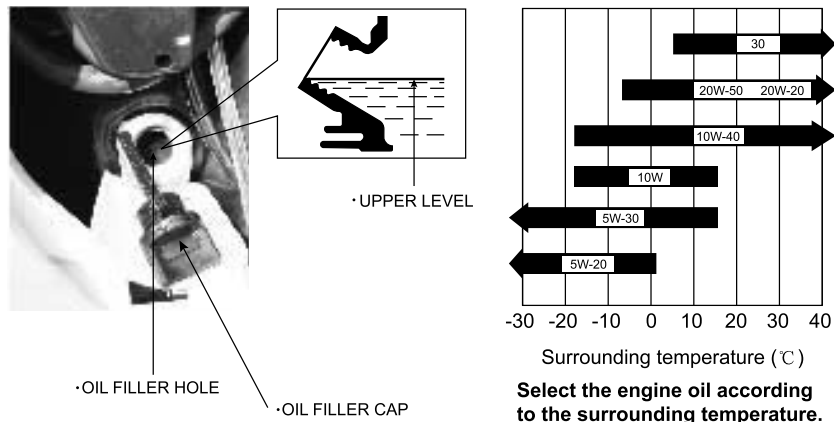

CAUTION:

Using nondetergent oil or 4-stroke engine oil could shorten the engine's service life.

Please use high-detergent, premium quality 4-stroke engine oil.

Running the engine with insufficient oil can cause serious engine damage.

NOTE: The Oil Alert System will automatically stop the engine before the oil level falls below the safe limit. However, to avoid the inconvenience of an unexpected shut-down, it is still advisable to inspect the oil level regularly.

② Check the fuel level.

Unleaded or lowleaded is preferred to minimize combustion chamber deposits.

If the fuel level is low, refuel the fuel tank.

Never use an oil/gasoline mixture or dirty gasoline.
Avoid getting dirt, dust or water in the fuel tank.
After refueling, tighten the fuel filler cap securely.

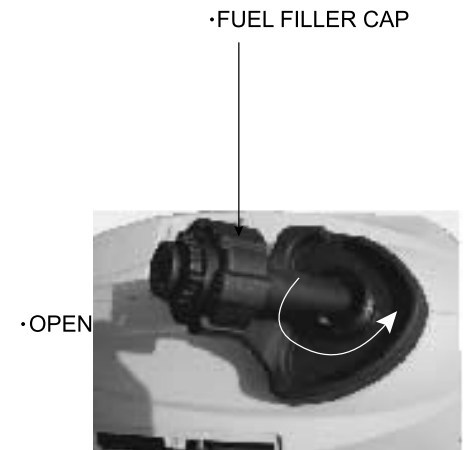
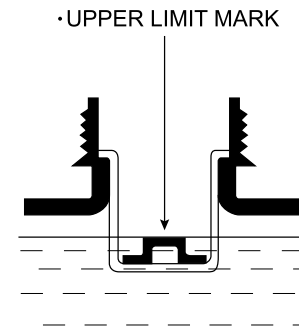

③ Check the air cleaner.

Check the air cleaner element to be sure it is clean and in good condition. Loosen the cover screw and remove the left side maintenance cover. Press the latch tab on the top of the air cleaner body, remove the air filter cover, check the element. Clean or replace the element if necessary.

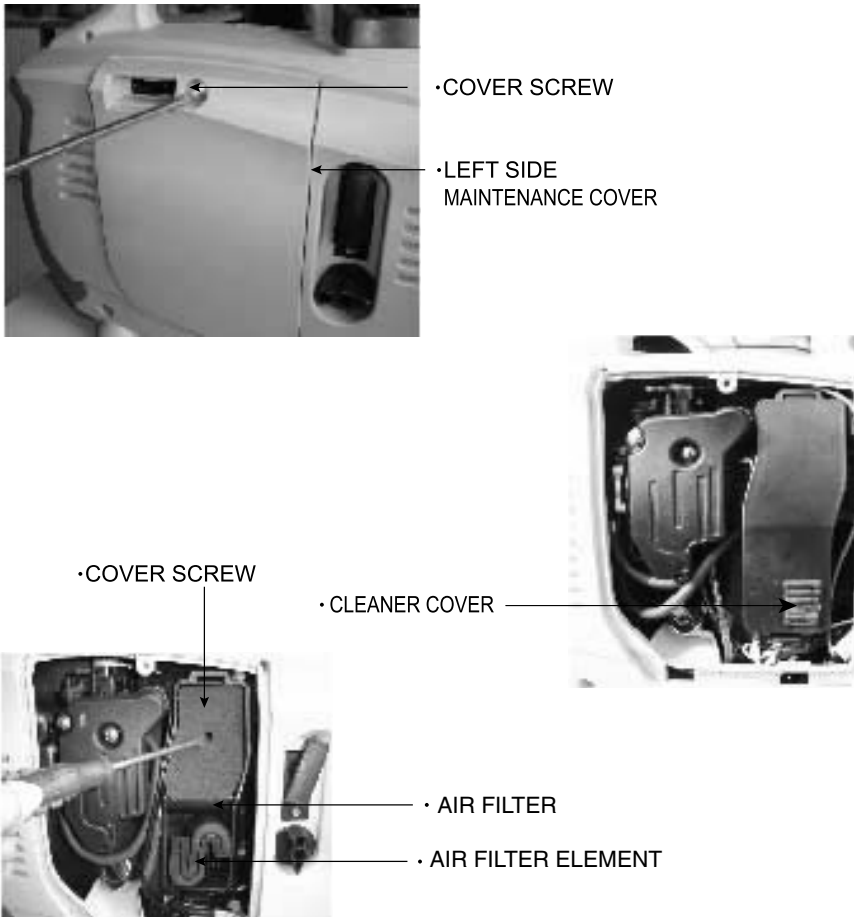

4. STARTING THE ENGINE

Before starting the engine, disconnect the load from the DC terminals.

- ① Turn the fuel cap lever fully clockwise to the ON position.
NOTE: Turn the fuel cap lever to the OFF position when transporting the generator.
- ② Turn the engine switch to the ON position.
Tune the fuel switch to the ON position.

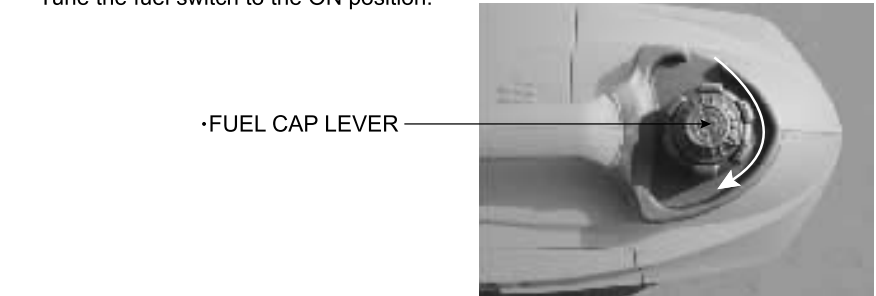

- ③ Move the choke lever to the CLOSED position.

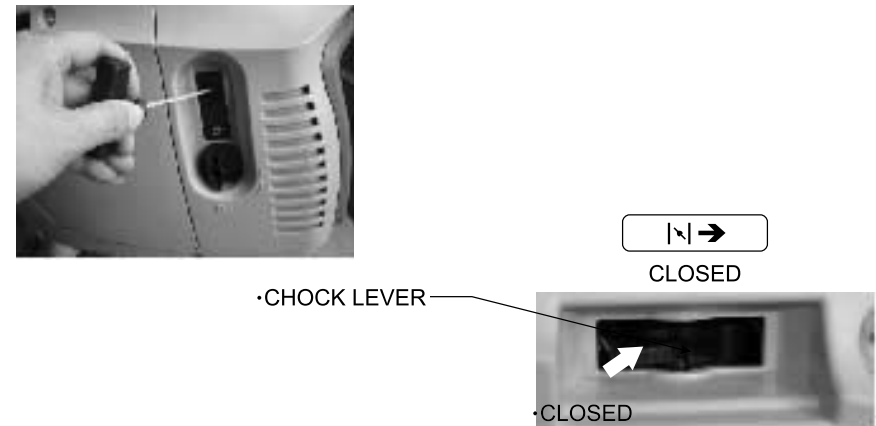

- ④ Pull the starter grip until resistance is felt, then pull the starter grip briskly toward the arrow as shown below.

CAUTION: Do not allow the starter grip to snap back.

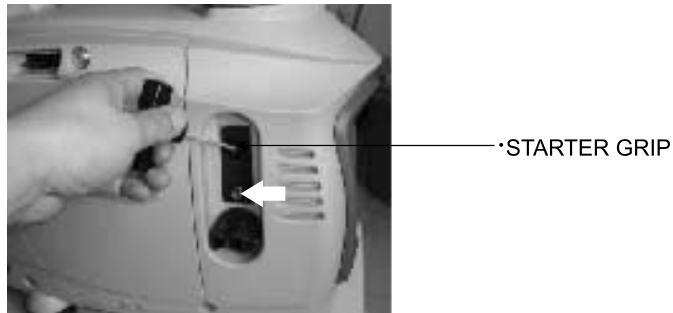

- ⑤ Move the choke lever to the OPEN position as the engine warms up.
NOTE: If the engine doesn't work by starting several times, check the engine oil level before trouble shooting other areas.

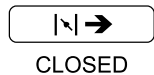

CLOSED

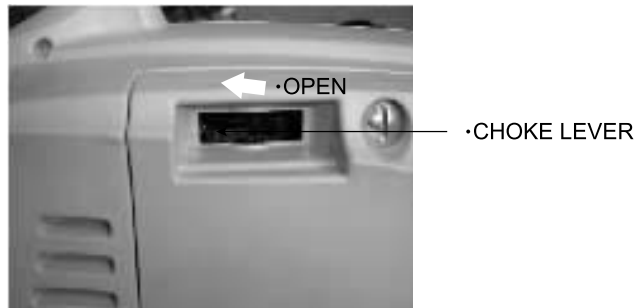

5. GENERATOR USE

⚠ WARNING

- To prevent electrical shock from faulty appliances, the generator should be grounded. Connect with a heavy wire between the generator ground terminal and on external ground source.
- Connections from standby power to a building's electrical system must be made by a qualified electrician and must comply with all applicable laws and electrical codes. Improper connections make electrical current from the generator to backfeed into the utility lines. Such backfeed may electrocute utility company workers or others who contact the lines during a power outage, and when utility power is restored the generator may explode, burn, or cause fires in the building's electrical system.

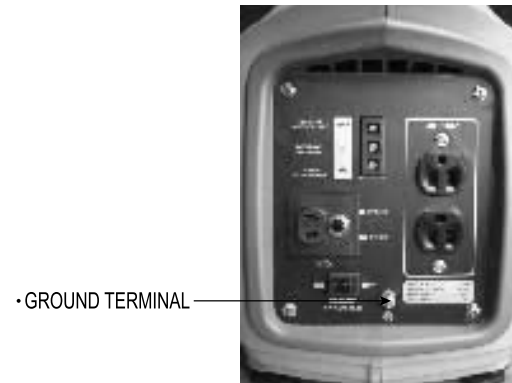

① AC applications

- Start the engine and make sure the output indicator light (green) is on. Make sure that the appliance to be used is switched off, and plug in the appliance.



- OIL ALERT INDICATOR LIGHT
- OUTPUT INDICATOR LIGHT
- AC RECEPTACLE

Output and Overload indicators

The output indicator light (green) will remain ON during operating conditions.

If the generator is overloaded (more than 1.0K VA), or if there is short in the connected appliance, the output indicator light (green) will go OFF, the overload indicator light (red) will go ON and current to the connected appliance will be shut off.

Stop the engine if the overload light (red) comes ON and investigate the overload source, start it after the overload light is OFF.

- Before connecting on appliance to the generator, check that it is in good order, and its electrical rating does not exceed the power of the generator. Then connect the power cord of the appliance, and start the engine.

② DC application

The DC receptacle may be used for charging 12 volt automotive-type batteries only.

- To prevent from creating a spark near the battery, connect charging cable first to the generator, then to the battery, Disconnect cable first at the battery.
- Connect the positive battery terminal to the positive charging cord. Do not reverse the charging cables, or serious damage to the generator and battery may occur .

NOTE:

- An overloaded DC circuit will trip the DC circuit protector (push button comes out). The DC circuit protector will trip when it's overloaded. If this happens, wait a few minutes before pushing in the circuit protector before resuming operation.



- DC CIRCUIT PROTECTOR



- PLUG

⚠ WARNING

- The battery gives off explosive gases; keep sparks, flames and cigarettes away. Provide adequate ventilation when charging.
- The battery contains sulfuric acid (electrolyte). If it gets into your skin or eyes it will cause severe burns. Wear protective clothing and a face shield.
 - If electrolyte touches your skin, flush with water.
 - If electrolyte gets into your eyes, flush with water for at least 15 minutes and consult a doctor.
- Electrolyte is poisonous.
 - Do not swallow!!
- KEEP OUT OF REACH OF CHILDREN

③ OIL ALERT SYSTEM

The Oil Alert system is designed to prevent engine damage caused by an insufficient amount of oil in the crankcase. Before the oil level in the crankcase falls below a safe limit, the Oil Alert system will automatically shut down the engine. The Oil Alert indicator light (red) will come on when you operate the starter, and the engine will not run. If this occurs, add engine oil.



•OIL ALERT INDICATOR LIGHT (RED)

6. STOPPING THE ENGINE

To stop the engine in an emergency, turn the engine switch to the STOP position.

IN NORMAL CONDITION:

- ① Switch off the connected equipment and pull out the inserted plug.



•PLUG

- ② Turn the engine switch to the STOP position.
Turn the fuel switch to the OFF position.



•STOP

③ Turn the fuel cap lever counterclockwise to the "OFF" position.

CAUTION: Be sure the fuel cap lever and the engine switch are "OFF" when stopping, transporting and/or storing the generator.

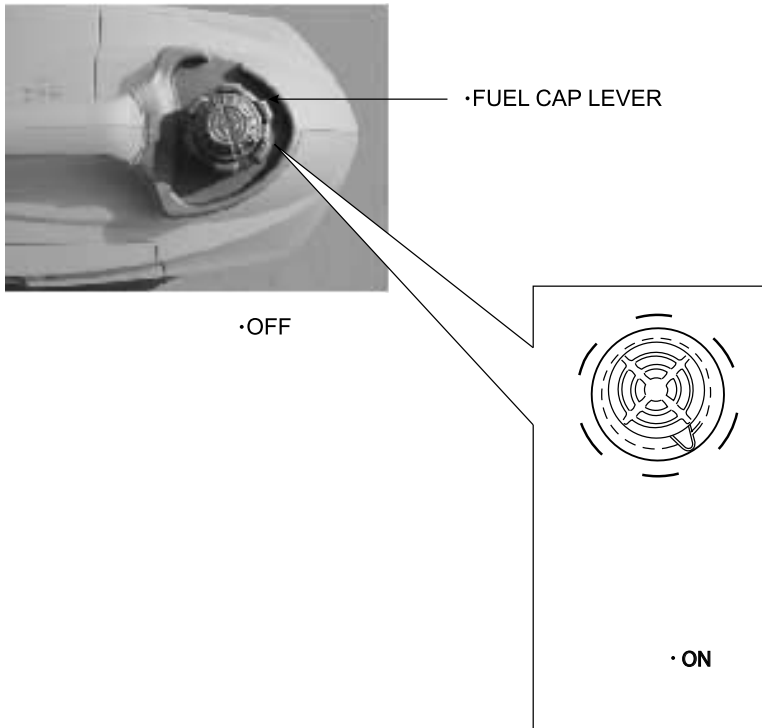

7. MAINTENANCE TIPS & INSTRUCTIONS

The purpose of maintenance and adjustment schedule is to keep the generator in the best operating condition. Inspect or service as scheduled in the table below.

⚠ WARNING

Shut off the engine before performing any maintenance. If the engine has to be run, make sure the area is well ventilated. The exhaust contains poisonous carbon monoxide gas.

CAUTION:

Use genuine parts or their equivalent parts. The use of replacement parts which are not of equivalent quality may damage the generator.

Maintenance Schedule

REGULAR SERVICE PERIOD (1) Perform of every indicated month or operating hour interval, whichever occurs first.		EACH USE	FIRST MONTH OR 10 HRS	EVERY 3 MONTHS OR 50HRS	EVERY 6 MONTHS OR 100HRS	EVERY YEAR OR 300HRS
ITEM						
Engine oil	Check	○				
	Change		○			
Air cleaner	Check	○				
	Clean		○ (2)			
Spark plug	Clean-adjust				○	
Valved clearance	Check-adjust					○ (3)
Fuel tank and strainer	Clean					○ (3)
Fuel line	Check	Every 2 years (Replace if necessary) (3)				

NOTE: (1) Run several hours to determine proper maintenance.

(2) Maintenance taken more frequently when used in dusty areas.

(3) These items should be serviced by an authorized dealer, unless the owner has the proper tools and is mechanically proficient. See the owner's Manual.

① CHANGING OIL

Drain the oil while the engine is still warm.

CAUTION: Make sure to turn the engine switch and the fuel cap lever OFF before draining.

- Loosen the cover screw and remove the left side maintenance cover.
- Remove the oil filler cap.
- Drain dirty oil into a container thoroughly
- Refill with the recommended oil, and check the oil level.
- Reinstall the left side maintenance cover and tighten the cover screw securely.

ENGINE OIL CAPACITY: 0.50L



•LEFT SIDE
MAINTENANCE COVER

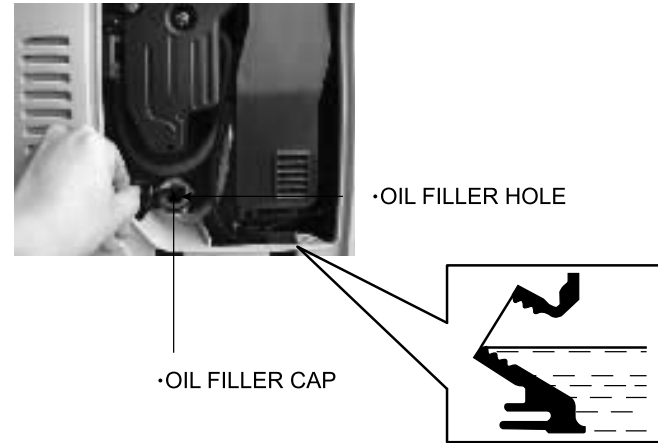

② AIR FILTER CLEANING

A dirty air filter will restrict air flowing into the carburetor. To prevent carburetor malfunction, service the air filter regularly. Service more frequently when operating the generator in extremely dusty areas.



WARNING

Do not use gasoline or low flash point solvents for cleaning. They are flammable and explosive under certain conditions.

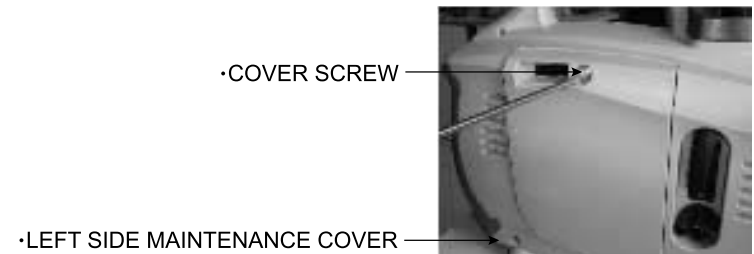

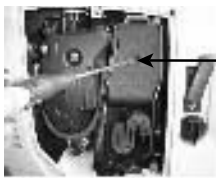

· AIR FILTER ELEMENT

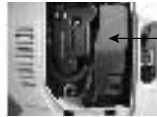

· AIR FILTER GAP

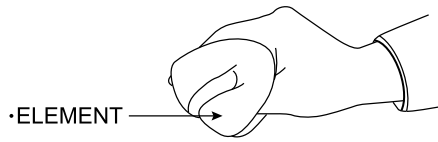

· ELEMENT

CAUTION: Never run the generator without the air cleaner. Rapid engine wear can occur.

- Loosen the cover screw and remove the left side maintenance cover.
- Press the latch tab on the top of the air cleaner body, and remove the air cleaner cover.
- Wash the element in a non-flammable or high flash point solvent and dry it thoroughly.
- Soak the element in clean engine oil and squeeze out the excess oil.
- Reinstall the air cleaner element and the cover.
- Reinstall the left side maintenance cover and tighten the cover screw securely.

③ SPARK PLUG SERVICE

RECOMMENDED SPARK PLUG: CR5H88 (NGK) U16FSR - UB (DENSO)

To ensure proper engine operation, the spark plug must be properly gapped and free of deposits.

- Remove the spark plug maintenance cover.

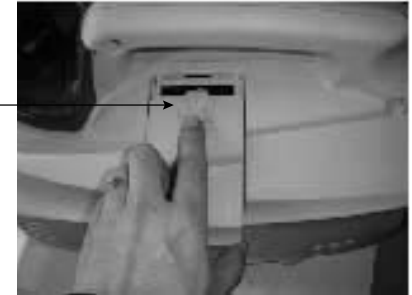

· SPARK PLUG MAINTENANCE COVER

- Remove the spark plug cap.
- Clean any dirt around the spark base.
- Use the wrench to remove the spark plug.

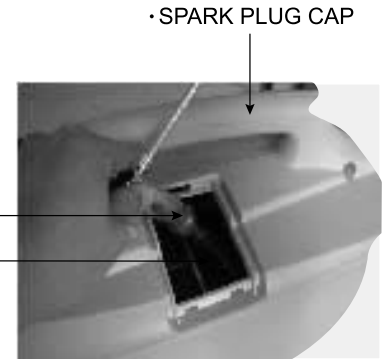

· SPARK PLUG CAP

· HANDLE

· PLUG WRENCH

8. TRANSPORTING/STORAGE

- Visually inspect the spark plug. Discard it if the insulator is cracked
Clean the spark plug with a wire brush if it can be reused.
- Measure the plug gap with a feeler gauge .
The gap should be 0.6-0.7mm, correct as necessary by carefully bending the side electrode .
- Install the spark plug carefully, by hand, to avoid cross-threading.

- After a new spark plug has been seated by hand, it should be tightened 1/2 turn with a wrench to compress its washer.
If a used plug is being reinstalled, it should only require 1/8 to 1/4 turn after being seated.
- reinstall the spark plug cap.
- Reinstall the spark plug maintenance cover.

CAUTION:

- **The spark plug must be securely tightened. An improperly tightened plug can become very hot and possibly damage the generator.**
- **Never use spark plug with an improper heat range.**

Make sure to drain the fuel completely. During transporting or during storage.

To prevent fuel spillage when transporting or during temporary storage, the generator should be secured upright in its normal operating position, with the engine switch OFF. The fuel cap level turned fully to the "OFF" position.

Avoid direct sunlight when putting the generator on a vehicle.
If the generator is left in an enclosed vehicle for many hours, high temperature inside the vehicle could cause possible explosion.

Before storing the unit for an extended period:
Be sure the storage area is free of excessive humidity and dust.

Long-term storage (over 30 days) information:
If you need store this engine for a long term (over 30 days), please follow the following instructions.

1. Make sure the gas tank is empty.
2. Empty out engine oil.
3. Turn all the the switches OFF.

9. TROUBLESHOOTING (FAQS)

When the engine will not start:

1.

Is there fuel in the tank?

NO

Refill the fuel tank.

2.

Is the engine switch on ?

NO

Turn the engine switch on.

3.

Is there enough oil in the engine?

NO

Add the recommended oil

4.

Is there a spark from the spark plug?

NO

Replace the spark plug.

Still No spark

Take the generator to an authorized dealer.



Be sure there is no spilled fuel around the spark plug.

YES

If the engine still does not start, take the generator to an authorized dealer.

To check:

1. Remove the spark plug cap and clean any dirt around the spark plug.
2. Remove the spark plug and install the spark plug in the plug cap.
3. Set the plug side electrode on the cylinder head to ground.
4. Pull the recoil starter, spark should jump across the gap.



Appliance does not operate:

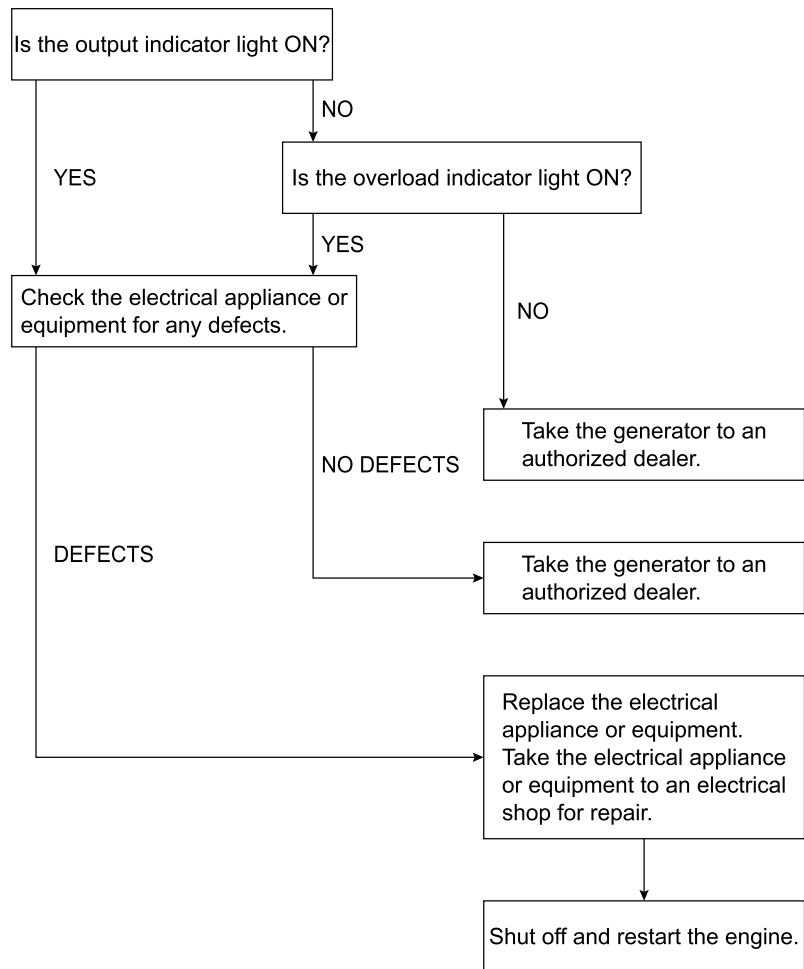

No electricity at the DC receptacle:

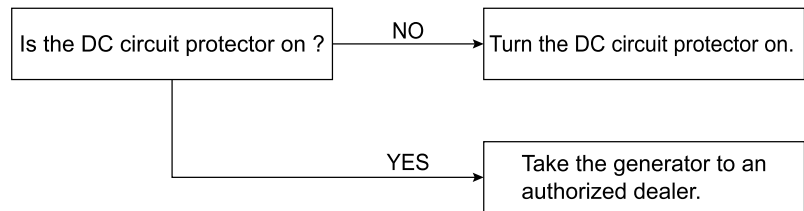

10. SPECIFICATIONS

Engine

Engine type	4-stroke, overhead valve, single cylinder
Displacement	86cc
Bore X stroke	∅ 54x 38mm
Compression ratio	10: 1
Engine speed	4000~ 5 000 r.p.m
Cooling system	Forced air
Ignition system	Full transistor
Oil capacity	0. 50L
Fuel tank capacity	3. 2L
Spark plug	A7RTC
Noise Level (ISO 8528- 10)	<68 dB (A)

Generator

AC Output	Rated Voltage (V)	220/ 230/ 240	110/ 120
	Rated Frequency (Hz)	50	60
	Rated Output (VA)	1600	1600
	Max Output (VA)	2000	2000

Dimensions and Weight

Length X Width X Weight	20.86"x11"x17.63"
Dry weight	47.4 lbs (21. 5 kg)

Limited Warranty

Gentron® warrants to the original purchaser who uses the product in a consumer application (personal, residential or household usage) that all products covered under this warranty are free from defects in material and workmanship for one year from the date of purchase. All products covered by this limited warranty which are used in commercial applications (i.e. income producing) are warranted to be free of defects in material and workmanship for 90 days from the date of original purchase. Products covered under this warranty include air compressors, air tools, service parts, pressure washers and generators.

Gentron® will repair or replace, at Gentron's sole option, products or components which have failed within the warranty period. Service will be scheduled according to the normal work flow and business hours at the service center location, and the availability of replacement parts. All decisions of Gentron® with regard to this limited warranty shall be final

This warranty gives you specific legal rights, and you may also have other rights which vary from state to state.

RESPONSIBILITY OF ORIGINAL PURCHASER (initial User):

To process a warranty claim on this product, DO NOT return item to the retailer. The product must be evaluated by an Authorized Warranty Service Center. For the location of the nearest Authorized Warranty Service Center contact the retailer or place of purchase.

Retain original cash register sales receipt as proof of purchase for warranty to work.

Use reasonable care in the operation and maintenance of the product as described in the Owner's Manual(s).

Deliver or ship the product to the Authorized Warranty Service Center. Freight costs, if any must be paid by the purchaser.

If the purchaser does not receive satisfactory results from the Authorized Warranty Service Center, the purchaser should contact Gentron®.

Limited Warranty (cont'd)

THIS WARRANTY DOES NOT COVER:

- Merchandise sold as reconditioned, used as rental equipment, or floor or display models.
- Merchandise that has become damaged or inoperative because of ordinary wear, misuse, cold, heat, rain, excessive humidity, freeze damage, use of improper chemicals, negligence, accident, failure to operate the product in accordance with the instructions provided in the Owner's Manual(s) supplied with the product, improper maintenance, the use of accessories or attachments not recommended by Gentron®, or unauthorized repair or alterations.
- Repair and transportation costs of merchandise determine not to be defective.
- Costs associated with assembly, required oil, adjustments or other installation and start-up costs.
- Expendable parts or accessories supplied with the product which are expected to become inoperative or unusable after a reasonable period of use.
- Merchandise sold by Gentron® which has been manufactured by and identified as the product of another company, such as gasoline engines. The product manufacturer's warranty, if any, will apply.
- ANY INCIDENTAL, INDIRECT OR CONSEQUENTIAL LOSS, DAMAGE, OR EXPENSE THAT MAY RESULT FROM ANY DEFECTS, FAILURE OR MALFUNCTION OF THE PRODUCT IS NOT COVERED BY THIS WARRANTY. Some states do not allow the exclusion, so it may not apply to you.
- IMPLIED WARRANTIES, INCLUDING THOSE OF MERCHANTABILITY OR FITNESS FOR A PARTICULAR PURPOSE, ARE LIMITED TO ONE YEAR FROM THE DATE OF ORIGINAL PURCHASE. Some states do not allow limitations on how long an implied warranty lasts, so the above limitations may not apply to you.