



UWKB Wheel Kit Installation

HERE'S HOW TO GET HELP

PLEASE HAVE THE MODEL AND SERIAL
NUMBER ON-HAND WHEN CALLING

UNITED STATES

Multiquip Corporate Office

18910 Wilmington Ave.
Carson, CA 90746
Contact: mq@multiquip.com

Tel. (800) 421-1244
Fax (800) 537-3927

Service Department

800-421-1244
310-537-3700

Fax: 310-537-4259

Technical Assistance

800-478-1244

Fax: 310-943-2238

MQ Parts Department

800-427-1244
310-537-3700

Fax: 800-672-7877
Fax: 310-637-3284

Warranty Department

800-421-1244
310-537-3700

Fax: 310-943-2249

MEXICO

MQ Cipsa

Carr. Fed. Mexico-Puebla KM 126.5
Momoxpan, Cholula, Puebla 72760 Mexico
Contact: pmastretta@cipsa.com.mx

Tel: (52) 222-225-9900
Fax: (52) 222-285-0420

CANADA

Multiquip

4110 Industriel Boul.
Laval, Quebec, Canada H7L 6V3
Contact: jmartin@multiquip.com

Tel: (450) 625-2244
Tel: (877) 963-4411
Fax: (450) 625-8664

UNITED KINGDOM

Multiquip (UK) Limited Head Office

Unit 2, Northpoint Industrial Estate,
Globe Lane,
Dukinfield, Cheshire SK16 4UJ
Contact: sales@multiquip.co.uk

Tel: 0161 339 2223
Fax: 0161 339 3226

© COPYRIGHT 2012, MULTIQUIP INC.

Multiquip Inc and the MQ logo are registered trademarks of Multiquip Inc. and may not be used, reproduced, or altered without written permission. All other trademarks are the property of their respective owners and used with permission.

The information and specifications included in this publication were in effect at the time of approval for printing. Illustrations, descriptions, references and technical data contained in this document are for guidance only and may not be considered as binding. Multiquip Inc. reserves the right to discontinue or change specifications, design or the information published in this publication at any time without notice and without incurring any obligations.

Your Local Dealer is:





UWKB Wheel Kit

For Use on Portable Generators, Pumps, and Welders

The following instructions are intended to assist the user in the assembly of the UWKB Wheel Kit for use on Multiquip portable generators, pumps, and welders. Please read the entire instructions before assembling the wheel kit.

REQUIRED TOOLS

- Ratchet Set with 10 mm socket
- Adjustable Wrench or 10 mm open-end wrench
- Pliers

PARTS

Verify that all parts are accounted for. See Table 1.

Table 1. UWKB Wheel Kit Parts				
Item No.	Part No.	Description	QTY.	Remarks
1	WK1312	Wheel/Tire, Solid	2	
2	8158	Pin, Cotter 3/16D x 1-1/2	2	
3	29748	Axle Mount W/A, Left (3 5/8")	1	
4	29749	Axle Mount W/A, Right (3 5/8")	1	
5	WK34715	Screw, M6 x 45	4	
6	0948	Washer, Flat SAE1/4	24	
7	WK34717	Nut, Nyloc M6	12	
8	WK2250	Clamp, Small	4	
9	WK2300	Clamp, Large	4	
10	29787	Pin, Clevis 5/16 x 1-1/2	2	
11	0300-B	Washer, Flat SAE 5/16	4	
12	0683	Pin, Cotter 3/32D x 3/4	2	
13	29739	Tube, Handle	2	
14	19717	Grip, Hand	2	
15	29748	Handle Mount W/A	2	
16	4001	Washer, Flat USS 3/8 PLD	2	
17	19716	Crutch Tip	2	
18	WK34716	Screw, HHC M6 x 90	8	

WORK SAFELY!

Only a **qualified service technician** with proper training should perform this installation. Follow all shop safety rules when performing this installation.

PROCEDURE

1. Assemble the axle mounts (See Figure 1). Push the wheel (item 1) on the axle mount (item 3) and then insert the cotter pin (item 2) through the outer axle hole. Bend the cotter pin to secure the wheel in place. Repeat this step for the other axle mount (item 4).

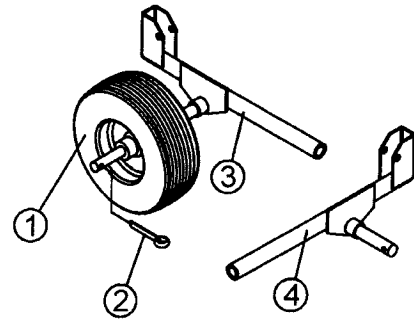

Figure 1. Axle Mount Assembly

NOTICE

Axle Mount Length is 3 5/8 inches.

2. Turning your unit on its side, or while having a second person lifting the side in the air, place the axle mount under the frame tubing on the side of the unit as shown in Figure 2.

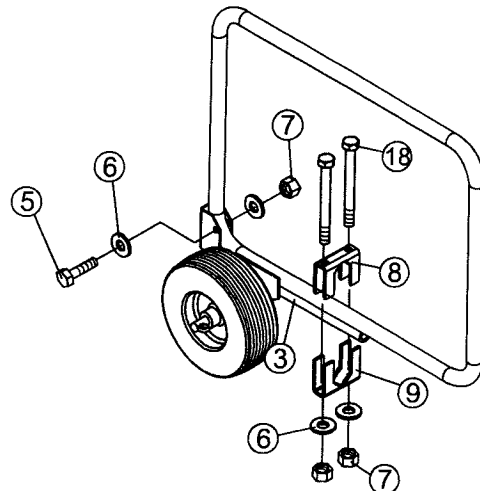

Figure 2. Securing Axle Mount to the Frame

NOTICE

Attach the axle mounts so that the wheels are located under the heaviest end of your unit. The placement of the axle mounts may differ on each type of equipment.

3. Set the rounded corner of the tubing in the bracket at the back of the axle mount and place a screw (item 5) and flat washer (item 6) through the holes, securing the tubing in place. Place another flat washer and a nyloc nut (item 7) on the threaded end of the screw and tighten.
4. Secure the axle mount to the frame tubing by placing a small clamp (item 8) over the frame tubing and the axle mount. Place a large clamp (item 9) over the small clamp. Insert screw (item 18) into the small clamp and secure with nyloc nut (item 7) and washer (item 6). Tighten screw until the clamp securely holds the axle mount to the frame tubing.
5. Repeat steps 2 through 4 to attach the axle mount to the opposite side of the unit.
6. Insert a flat washer (item 16) into the crutch tip (item 17) and place the combined items over the open end of the handle mount (item 15). See Figure 3.

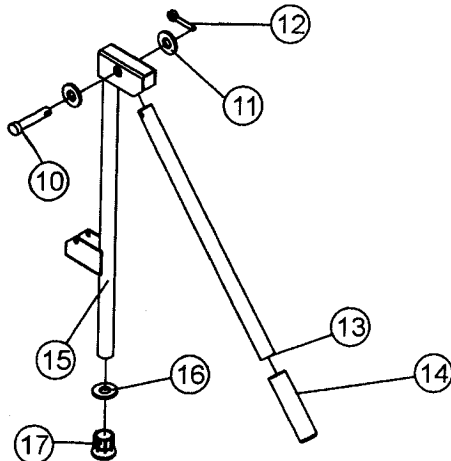

Figure 3. Handle Mount Assembly

7. Insert the end of the handle tube (item 13) with the screw hole into the top bracket of the handle mount. Slide a clevis pin (item 10) and flat washer (item 11) through the bracket and handle tube holes. Place another flat washer on the end of the clevis pin. Insert a cotter pin (item 12) through the hole in the clevis pin to secure the handle tube to the handle mount.
8. Slide the hand grip (item 14) over the open end of the handle tube.

9. Lifting the front of the unit, set the rounded corner of the frame tubing into the support bracket on the handle mount (Figure 4). Secure the handle mount to the frame tubing by placing a large clamp (item 9) around the frame tubing and the handle mount. See Figure 4.

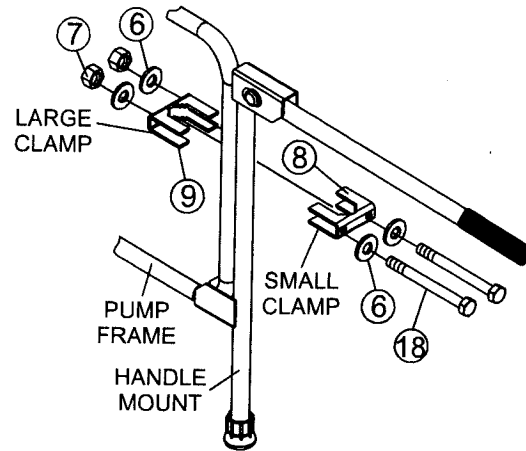

Figure 4. Securing Handle Mount to the Frame

10. Insert the small clamp (item 8) on the other side of the handle mount and frame tubing, so that the large and small clamps are facing each other.
11. Insert screw (item 18) into small clamp and secure with nyloc nuts (item 7). Tighten screw until the clamp securely holds the handle mount to the frame tubing.
12. Repeat steps 9 through 11 to attach the handle mount to the other side of the unit.