

END SUCTION CENTRIFUGAL PUMP SERIES "PC" (NON-SELF PRIMING) EXPLODED VIEW PARTS DIAGRAM

PARTS LIST
PP-9960I
APRIL 2016

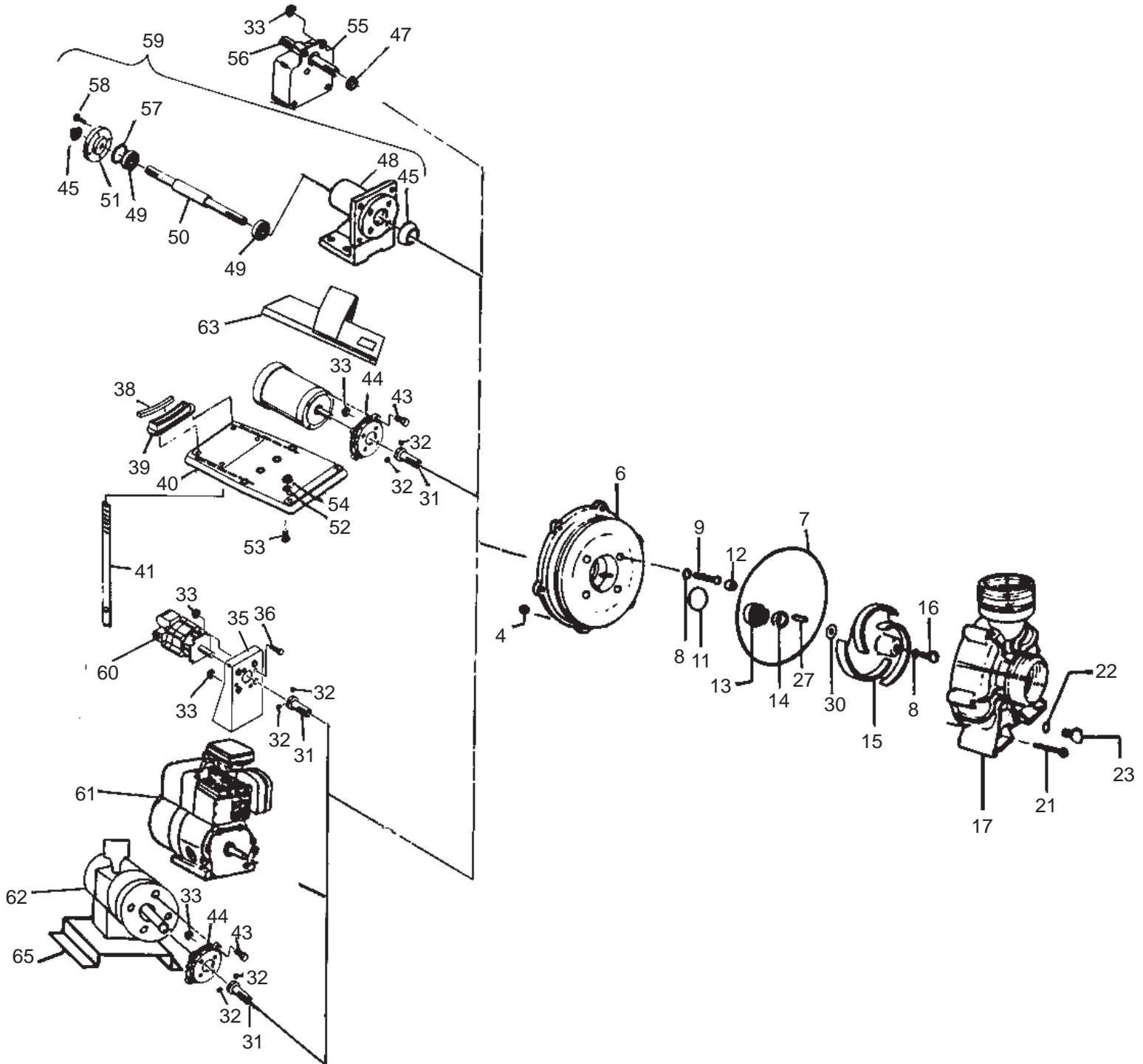
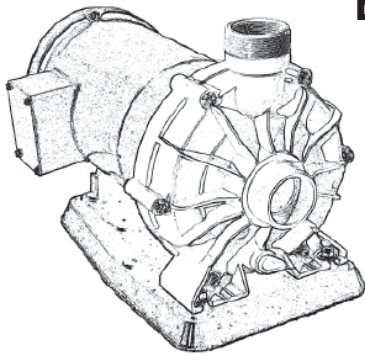

"PC" PUMP PARTS LIST

ITEM #	PART #	PART DESCRIPTION	QTY/PUMP	ITEM #	PART #	PART DESCRIPTION	QTY/PUMP
4	58-0721 10	NUT, BODY, Stainless Steel, 1/4"-20 Hex	6	21	58-0720 10	SCREW, Volute, stainless steel, 1/4"-20 X 2.375" long for 1-1/2" / 2" pump	6
	58-0721 10F	FLANGE NUT, BODY, Stainless Steel, 1/4"-20, for Polypropylene pumps only	6		58-1386 10	SCREW, Volute, stainless steel, 1/4"-20 X 2.75" long for 3" pump	6
6	58-1016 20	BRACKET, Noryl, gray	1	22	58-1009 71	O-RING, Drain plug, Buna-N	1
	58-1016 30	BRACKET, Polyester, black	1		58-1009 72	O-RING, Drain plug, EPDM	1
	58-1016 40	BRACKET, Polypropylene, gray	1		58-1009 73	O-RING, Drain plug, Viton	1
	58-1016 60	BRACKET, Ryton, black	1	23	58-0723 20	PLUG, Drain, Noryl, gray	1
7	58-1316 71	O-RING, volute, Buna-N	1		58-0723 30	PLUG, Drain, Polyester, black	1
	58-1316 72	O-RING, volute, EPDM	1		58-0723 40	PLUG, Drain, Polypropylene, gray	1
	58-1316 73	O-RING, volute, Viton	1		58-0723 60	PLUG, Drain, Ryton, brown	1
8	58-0717 71	O-RING, Screw, Buna-N	5	27	58-0718	KEY, steel	1
	58-0717 72	O-RING, Screw, EPDM	5		58-0718 10	KEY, stainless steel	1
	58-0717 73	O-RING, Screw, Viton	5		58-0718 30	KEY, molded polyester	1
9	58-0715 10	SCREW, Bracket, Stainless Steel for pumps close coupled to engine, cast iron ped. 5/16"-24 X 1.25" long	4	30	58-0778 11	SHIM, .006"	as required
	58-0715 91	SCREW, Bracket, Hastelloy C for pumps close coupled to engine, cast iron ped. 5/16"-24 X 1.25" long	4		58-0778 12	SHIM, .015"	as required
	58-2167 10	SCREW, Bracket, Stainless Steel for pumps plastic ped. mounted, Close coupled to Electric, Hydraulic or pneumatic motor, 5/16"-18 X 1.5" long	4		58-0778 13	SHIM, .030"	as required
	58-0728 91	SCREW, Bracket, Hastelloy C for pumps plastic ped. mounted, close coupled to electric, hydraulic or pneumatic motor, 5/16"-18 X 1.5" long	4	31	58-1014 10	ADAPTER, Shaft, for close coupled electric or pneumatic motor, Stainless Steel, 625" bore	1
11	58-0976 71	O-RING, Shaft Seal, Buna-N	1		58-1165 10	ADAPTER, Shaft, stainless steel, for hydraulic motor, .563" bore	1
	58-0976 72	O-RING, Shaft Seal, EPDM	1	32	58-0883	SET SCREW, 1/4"-20 X .25" long, steel	2
	58-0976 73	O-RING, Shaft Seal, Viton	1	33	58-0745	KEPNUT, 5/16"-18, plated steel	4
12	58-0750 40	PLUG, Bracket screw protector, Polypropylene (viton pumps only)	4	35	58-1011 20	PEDESTAL, hydraulic motor, molded plastic	1
	58-0750 90	PLUG, Bracket screw protector, Fluoropolymer (ryton pumps only)	4	36	58-0729H	SCREW, for mounting hydraulic motor to pedestal, 5/16"-18 X 1" long Plated steel	4
11, 13 & 14	58-0714 11	SEAL, shaft, Buna-N / 316 SS / Carbon / Ceramic	1	38	58-1826 71	PAD, rubber, saddle	1
	58-0714 12	SEAL, shaft, EPDM / 316 SS / Carbon / Ceramic	1	39	58-1828 90	SADDLE, Electric motor, 6.625" diameter, molded plastic	1
	58-0714 14	SEAL, shaft, Viton / 316 SS / Carbon / Ceramic	1		58-1825 90	SADDLE, Electric motor, 5.688" diameter, molded plastic	1
	58-0714 15	SEAL, shaft, Hastelloy C / Teflon / Silicon Carbide	1	40	58-1846 40	BASEPLATE, plastic, for pumps close coupled to electric motors	1
	58-0714 92SG	SEAL, shaft, non metallic, ECTFE, EPDM Siliconized graphite	1	41	58-0934 10	STRAP, for close coupled electric motor, stainless steel	1
	58-0714 94SG	SEAL, shaft, non metallic, ECTFE, Viton, siliconized graphite	1	43	58-1015 10	SCREW, hex head cap, 3/8"-16 X 1.25", stainless steel	4
	58-46250 11	SEAL, shaft, 316 SS / Buna-N / Siliconized graphite	1	44	58-1010 20	ADAPTER, motor, for pump close coupled to electric or pneumatic motor, molded plastic	1
	58-46250 12	SEAL, shaft, 316 SS / EPDM / Siliconized graphite	1	45	58-1955 71	SEAL, lip, Buna-N, .710" ID	2
	58-46250 13	SEAL, shaft, 316 SS / Viton / Siliconized graphite	1	47	58-0884 71	SLINGER, Buna-N	1
15	58-0667 30	IMPELLER, Polyester*, 3 vane, .535" wide 4.75" dia	1	48	58-1951 90	HOUSING, bearing, cast iron	1
	58-0704 30	IMPELLER, Polyester*, 3 vane, .535" wide 5.5" dia	1	49	58-1954 90	BEARING, ball, .787", ID	2
	58-0706 30	IMPELLER, Polyester*, 5 vane, .535" wide 5.5" dia	1	50	58-1952 10	SHAFT, stainless steel, .75" diameter	1
	58-0707 30	IMPELLER, Polyester*, 5 vane, .535" wide 5.0" dia	1		58-1952 91	SHAFT, Hastelloy C, .75" diameter	1
	58-0708 30	IMPELLER, Polyester*, 3 vane, .535" wide 5.0" dia	1	51	58-1953 10	PLATE, end, stainless steel	1
	58-0709 30	IMPELLER, Polyester*, 3 vane, .535" wide 5.25" dia	1	52	58-0730	FLAT WASHER, 5/16" plated steel	2
	58-0975 30	IMPELLER, Polyester*, 4 vane, .975" wide 4.75" dia	1	53	58-0729	SCREW, plated steel, 5/16"-18 X 1"	2
16	58-0716 10	SCREW, Impeller, Stainless Steel, 5/16"-24 X .75" long	1	54	58-0745	KEPNUT, 5/16"-18, plated steel	2
	58-0716 91	SCREW, Impeller, Hastelloy C, 5/16"-24 X .75" long	1	55	58-0729 20	BEARING PEDESTAL, molded plastic	1
17	58-1017 30	VOLUTE, 1-1/2" female, 2" male, NPT polyester black	1	56	58-0777	BEARING/SHAFT ASSEMBLY, Standard, carbon steel	1
	58-1018 31	VOLUTE, Buna-N lined, 1-1/2" female, 2" male NPT, Polyester, black	1		58-0777 10	BEARING/SHAFT ASSEMBLY, with stainless steel shaft sleeve	1
	58-1018 32	VOLUTE, EPDM lined, 1-1/2" female, 2" male NPT, Polyester, black	1	55&56	58-2053 01	ASSEMBLY, PEDESTAL, 3/4" carbon steel shaft	1
	58-1017 20	VOLUTE, 1-1/2" female, 2" male NPT, Noryl, gray	1		58-2053 02	ASSEMBLY, PEDESTAL, with stainless steel shaft sleeve	1
	58-1018 21	VOLUTE, Buna-N lined, 1-1/2" female, 2" male NPT, Noryl, gray	1	57	58-1956 10	SHIM, bearing shaft, cast metal pedestal, .006" thick	as required
	58-1018 22	VOLUTE, EPDM lined, 1-1/2" female, 2" male NPT, Noryl, gray	1	58	58-2525 10	SCREW, hex, 1/4"-20 X 3/4", stainless steel	4
	58-1017 40	VOLUTE, 1-1/2" female, 2" male NPT, Polypropylene, gray	1	59	58-1950 01	BEARING AND PEDESTAL ASSEMBLY with 3/4" stainless steel shaft (Includes items 45, 48, 49, 50, 51, 57 & 58)	1
	58-1017 60	VOLUTE, 1-1/2" female, 2" male NPT, Ryton, black	1		58-1950 01H	SAME, with Hastelloy C shaft	1
	58-1019 20	VOLUTE, 3" male NPT, Noryl, gray	1	60	58-0686	MOTOR, Hydraulic	1
	58-1019 30	VOLUTE, 3" male NPT, Polyester, black	1	61		ENGINE, consult factory	1
	58-1019 40	VOLUTE, 3" male NPT, Polypropylene, gray	1	62	58-0926	MOTOR, pneumatic	1
	58-1019 60	VOLUTE, 3" male NPT, Ryton, black	1	63	58-0028	BASEPLATE KIT, standard duty, call factory for details for flex coupling to electric motors	1
	58-1020 31	VOLUTE, Buna-N lined, 3" male NPT, Polyester, black	1		58-0016	BASEPLATE KIT, Heavy duty, call factory for details for flex coupling to electric motors	1
	58-1020 32	VOLUTE, EPDM lined, 3" male NPT, Polyester, black	1	65	58-0929	BASEPLATE, for pumps close coupled to pneumatic motor, painted steel	1
	58-1020 21	VOLUTE, Buna-N lined, 3" male NPT, Noryl, gray	1				
	58-1020 22	VOLUTE, EPDM lined, 3" male NPT, Noryl, gray	1				
	58-1217 20	VOLUTE, 1-1/2" female, 2" male BSP, Noryl, gray	1				
	58-1217 30	VOLUTE, 1-1/2" female, 2" male BSP, Polyester, black	1				
	58-1217 40	VOLUTE, 1-1/2" female, 2" male BSP, Polypropylene, gray	1				
	58-1217 60	VOLUTE, 1-1/2" female, 2" male BSP, Ryton, black	1				

*NOTE: If Noryl impellers are required, change the second to last digit in the part number from 3 to 2.
 If Ryton impellers are required, change the second to last digit in the part number from 3 to 6.
 If Polypropylene impellers are required, change the second to last digit in the part number from 3 to 4.

NOTE: All specifications, as shown, are subject to change without previous notice.

servicing
 industry
 worldwide

PACER® PUMPS
 Div. of ASM Industries