

SELF-PRIMING CENTRIFUGAL PUMP SERIES "I"

PARTS LIST
PP-9940G
JAN 2012

EXPLODED VIEW PARTS DIAGRAM

Impellers, (item #13) may be ordered with the seal half (item #22) installed. The part number for these assemblies is the same as the impeller part number except that the last digit is a "1" for Buna-N seal, a "2" for EPDM seal, and a "3" for Viton seal. For example: Assembly #58-0683 31 consists of impeller #58-0683 30 (item #13) and a Buna-N seal half (item #22).

Support assemblies are also available with the shaft seal half installed. This includes the seal o-ring (item #26). The part number for these assemblies is the same as the support (item #6) part number except that the last digit is a "1" for Buna-N seal, a "2" for EPDM seal, or a "4" for Viton seal. For example: Assembly #58-1301 32 consists of support #58-1301 30 (item #6), EPDM seal half (item #25) and EPDM shaft seal o-ring (item #26).

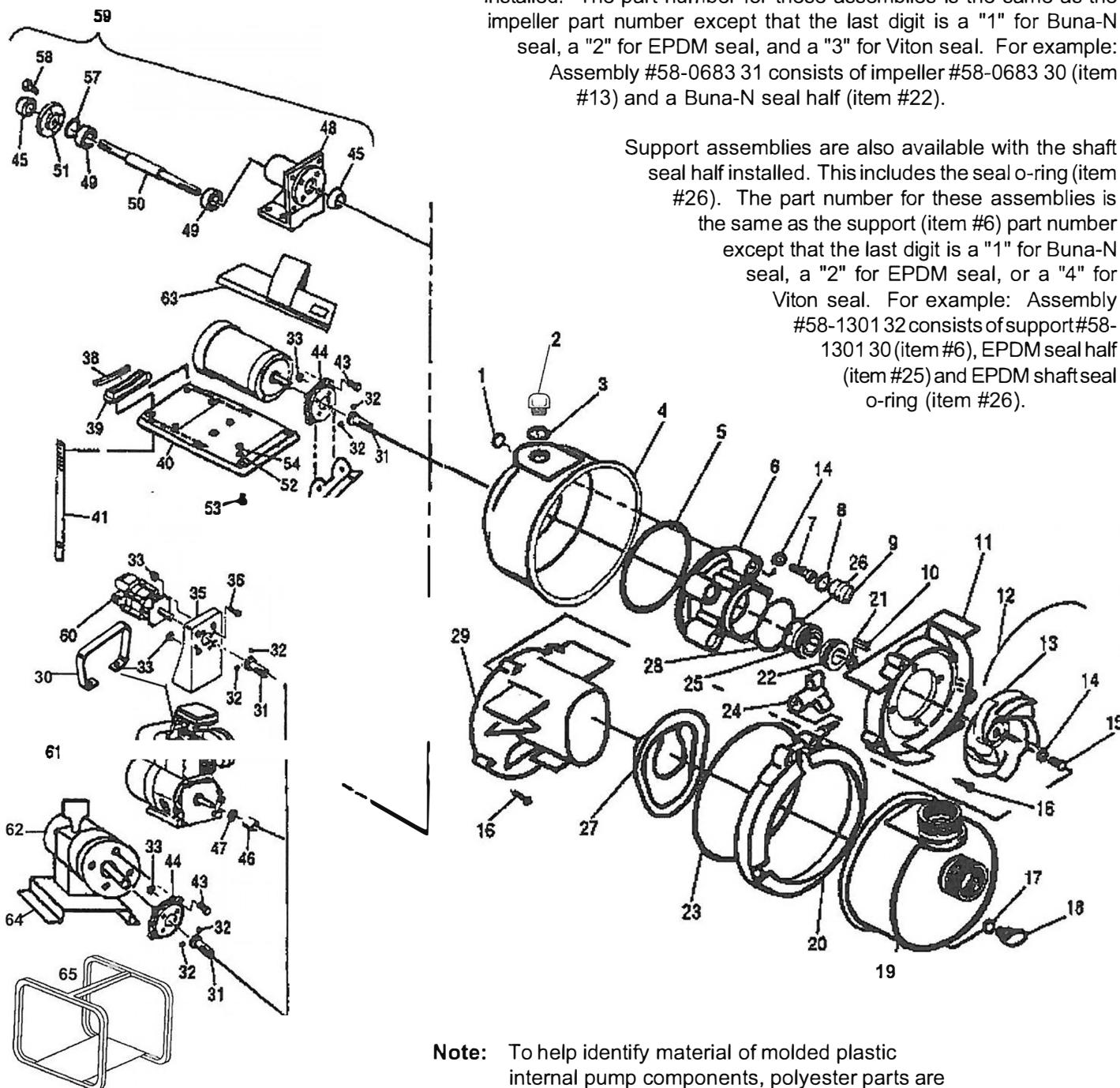

Note: To help identify material of molded plastic internal pump components, polyester parts are black in color. Polypropylene parts are gray.

NOTE: All specifications, as shown, are subject to change without previous notice.

F.O.B. Lancaster PA

PACER® PUMPS

Div. of ASM Industries, Inc.

servicing
industry
worldwide

(Printed in U.S.A.)

ITEM#	PART#	PART DESCRIPTION	QTY. PUMP	ITEM#	PART#	PART DESCRIPTION	QTY./PUMP
1	58-1244 30	SPACER, Polyester, Black	4	58-46250 13	SHAFT SEAL, VITON, 316 S.S., Siliconized Graphite	1	
	58-1244 60	SPACER, Ryton, Brown, (ISP Model Pumps)	4	23	58-1312 71	O-RING, Body, BUNA-N	1
2	58-0722 30B	PLUG, Filler, Polyester, Black	1		58-1312 72	O-RING, Body, EPDM	1
	58-0722 40	PLUG, Filler, Polypropylene, Gray	1		58-1312 73	O-RING, Body, VITON	1
	58-0722 60	PLUG, Filler, Ryton, Brown	1	24	58-1282 90	KNOB, V-Band Clamp	1
3	58-0765 71	O-RING, Filler Plug, BUNA-N	1		58-0976 71	O-RING, Shaft Seal, BUNA-N	1
	58-0765 72	O-RING, Filler Plug, EPDM	1		58-0976 72	O-RING, Shaft Seal, EPDM	1
	58-0765 73	O-RING, Filler Plug, VITON	1		58-0976 73	O-RING, Shaft Seal, VITON	1
4	58-1308 10	BODY, Rear, 316 Stainless Steel	1	27	58-1872 71	CHECK VALVE, BUNA-N	1
5	58-1361 71	O-RING, Support, BUNA-N	1		58-1872 72	CHECK VALVE, EPDM	1
	58-1361 72	O-RING, Support, EPDM	1		58-1872 73	CHECK VALVE, VITON	1
	58-1361 73	O-RING, Support, VITON	1	28	58-1203 71	O-RING, Rear Volute, BUNA-N	1
6	58-1301 30	SUPPORT, Polyester, Black	1		58-1203 72	O-RING, Rear Volute, EPDM	1
	58-1301 40	SUPPORT, Polypropylene, Gray	1		58-1203 73	O-RING, Rear Volute, VITON	1
	58-1301 60	SUPPORT, Ryton, Brown	1	29	58-1303 30	VOLUTE, Front, Flat, Polyester, Black	1
7	58-0715 10	SCREW, 5/16"-24 x 1.25" long, S.S. for pumps close-coupled to engines, pedestal mounted	4		58-1303 40	VOLUTE, Front, Flat, Polypropylene, Gray	1
	58-2167 10	SCREW, 5/16"-18 x 1.5", S.S. for pumps close-coupled to electric, hydraulic or pneumatic motor	4		58-1303 60	VOLUTE, Front, Flat, Ryton, Brown	1
8	58-1245 71	O-RING, Screw Plug, BUNA-N	4		58-1304 31	VOLUTE, Front, BUNA Lined, Polyester, Black	1
	58-1245 72	O-RING, Screw Plug, EPDM	4		58-1304 32	VOLUTE, Front, EPDM Lined, Polyester, Black	1
	58-1245 73	O-RING, Screw Plug, VITON	4	30	58-1238	HANDLE, Steel, for 3.5HP engine driven pumps only	1
9	58-1233 30	PLUG, Screw, Polyester, Black	4	31	58-1014 10	ADAPTER, Shaft, .625" Dia. Bore, Stainless Steel for close-coupled electric or pneumatic motor, attaches with set screws	1
	58-1233 40	PLUG, Screw, Polypropylene, Gray	4		58-1165 10	ADAPTER, Shaft, .563" Dia. Bore, Stainless Steel for Hydraulic Motor	1
	58-1233 60	PLUG, Screw, Ryton, Brown	4	32	58-0883	SCREW, Set, 1/4"-20 x 1/4" Long, Steel	2
10	58-0718	KEY, 3/16" Sq. x 15/16" long, Steel	1	33	58-0745 10	KEPNUT, 5/16"-18, Stainless Steel	as required
	58-0718 10	KEY, 3/16" Sq. x 15/16" long, Stainless Steel	1	35	58-1011 20	BASE, Hydraulic Motor, Molded Plastic	1
11	58-1302 30	VOLUTE, Rear, Polyester, Black	1	36	58-0729H	SCREW, 5/16"-18 x 1" Long, Plated Steel	4
	58-1302 40	VOLUTE, Rear, Polypropylene, Gray	1	37	58-2100 10	BRACKET, for close-coupled Electric, Stainless Steel	1
	58-1302 60	VOLUTE, Rear, Ryton, Brown	1	38	58-1826 71	PAD, Rubber, Saddle	1
12	58-1246 71	O-RING, Segment, BUNA-N	1	39	58-1828 90	SADDLE, Electric Motor, 6.626" Dia., Molded Plastic	1
	58-1246 72	O-RING, Segment, EPDM	1	40	58-1846 40	BASEPLATE, Polypropylene, for close-coupled electric motor	1
	58-1246 73	O-RING, Segment, VITON	1	41	58-0934 10	STRAP, Electric Motor, Stainless Steel	1
13	58-0683 30	IMPELLER, Polyester, Black	1	43	58-1015 10	SCREW, 3/8"-16 x 1.25" Long, Stainless Steel	4
	58-0683 40	IMPELLER, Polypropylene, Gray	1	44	58-1010 20	ADAPTER for close-coupling to 56C frame electric or pneumatic motor, molded plastic	1
	58-0683 60	IMPELLER, Ryton, Brown	1	45	58-1955 71	SEAL, LIP, .717" I.D., BUNA-N	2
14	58-0717 71	O-RING, Screw, BUNA-N	5	46	58-0882 90	SHAFT SLEEVE, Polyethylene, Heat Shrinkable	1
	58-0717 72	O-RING, Screw, EPDM	5	47	58-0884 71	SLINGER, BUNA-N	1
	58-0717 73	O-RING, Screw, VITON	5	48	58-1951 90	HOUSING, Bearing, Cast Metal	1
15	58-0716 10	SCREW, Impeller, 5/16"-24 x .75" long, S.S.	1	49	58-1954 90	BEARING, Ball, .787" I.D.	2
16	58-1348 10	SCREW, Volute, #10 x .75", Stainless Steel	7	50	58-1952 10	SHAFT, Stainless Steel, .75" Diameter	1
17	58-1009 71	O-RING, Drain Plug, BUNA-N	1	51	58-1953 10	PLATE, end, Stainless Steel	1
	58-1009 72	O-RING, Drain Plug, EPDM	1	52	58-0730 10	FLAT WASHER, .563", Stainless Steel	2
	58-1009 73	O-RING, Drain Plug, VITON	1	53	58-0729 10	SCREW, 5/16"-18 x 1" Long, Stainless Steel	2
18	58-0723 30	PLUG, Drain, Polyester, Black	1	54	58-0745 10	KEPNUT, 5/16"-18, Stainless Steel	2
	58-0723 40	PLUG, Drain, Polypropylene, Gray	1	57	58-1956 10	SHIM, Bearing Shaft, Cast Metal Pedestal, .006" thick, Stainless Steel	as required
	58-0723 60	PLUG, Drain, Ryton, Brown	1	58	58-2525 10	SCREW, Hex, 1/4"-20 x 3/4", Stainless Steel	4
19	58-2012 10	BODY, Front, NPT, 316 Stainless Steel	1	59	58-1950 01	BEARING & PEDESTAL Assembly with 3/4" S.S. shaft (includes items 45, 48, 49, 50, 51, 57 & 58)	1
	58-2013 10	BODY, Front, BSP, 316 Stainless Steel	1	60	58-0686	MOTOR, Hydraulic	1
20	58-1280 01	ASS'Y., Stainless Steel V-Band with Knob	1	61		ENGINE, Consult factory with model number	1
21	58-0778 11	SHIM, Impeller, .006", Stainless Steel as required		62	58-0926	MOTOR, Pneumatic	1
	58-0778 12	SHIM, Impeller, .015", Stainless Steel as required		63	58-0109	BASEPLATE KIT, Std. Duty, for flex-coupling to electric motors	1
	58-0778 13	SHIM, Impeller, .030", Stainless Steel as required		64	58-0929	BASEPLATE, for pumps close-coupled to hydraulic or pneumatic motor	1
22, 25 & 26	58-0714 11	SHAFT SEAL, BUNA-N, 316 S.S. Carbon/Ceramic	1	65	58-0009	ROLL CAGE, Standard equipment on all engine driven 'I' pumps	1
	58-0714 12	SHAFT SEAL, EPDM, 316 S.S. Carbon/Ceramic	1				
	58-0714 14	SHAFT SEAL, VITON, 316 S.S. Carbon/Ceramic	1				
	58-0714 15	SHAFT SEAL, Hastelloy C, Teflon, Silicon Carbide	1				
	58-0714 92SG	SHAFT SEAL, Non-Metallic, ECTFE, EPDM, Siliconized Graphite	1				
	58-0714 94SG	SHAFT SEAL, Non-Metallic, ECTFE, VITON, Siliconized Graphite	1				
	58-46250 11	SHAFT SEAL, BUNA-N, 316 S.S. Siliconized Graphite	1				
	58-46250 12	SHAFT SEAL, EPDM, 316 S.S., Siliconized Graphite	1				