

MYERS® P50 & P100 SERIES

The Myers P series effluent pumps are designed specifically for multi-pump pressure collection, septic tank effluent pumping (S.T.E.P.) and high head drainage applications. The high efficiency, single-vane, enclosed impellers provide steep, non-overloading performance curves, which are ideal for these applications. These pumps deliver more capacity at higher heads than most pumps in this class. The combination of the most rugged materials ensure years of trouble-free, dependable service.



APPLICATIONS

Effluent removal, sump drainage, water transfer, flood control

SPECIFICATIONS

Capacities – Up to 60 GPM (227 LPM)
Shut-off Head – Up to 124' (37.8 m)
Max. Spherical Solids – 3/4" (19 mm)
Liquids Handling – Domestic, effluent and drain water
Intermittent Liquid Temperature – Up to 140°F (60°C)
Motor/Electrical Data – 1/2 HP, 115V or 230V, 1Ø; 1 HP, 230V, 1Ø, oil-filled, permanent split capacitor type, 3450 RPM, 60Hz
Acceptable pH Range – 6-9
Specific Gravity – .9-1.1
Viscosity – 28-35 SSU
Discharge, NPT – 1-1/2" (38 mm)
Housing – Cast iron
Minimum Sump Diameter – Simplex: 24" (61 cm); Duplex: 36" (91.4 cm)
Power Cord – 20', 14/3 SJOW, SJOW-A

FEATURES

Rugged and Dependable

Durable, oil-filled motor for continuous bearing lubrication and maximum heat dissipation

Design Meets Demand

Single-vane, enclosed impeller provides steep, non-overloading performance curves for pressure collection and S.T.E.P. applications

Closed Case

Enclosed impeller eliminates jamming between impeller and volute – engineered thermoplastic composition

Powerful Starts

High-torque, permanent split capacitor (PSC) motor; no starting switches or relays to wear out

No Burnout

On-winding current and temperature sensitive overload to protect against costly burnout

Thermal Failsafe

Heat sensor overload protection with automatic reset when motor cools to a safe operating temperature

Twice the Protection

Optional leak probe senses water leakage past seal (dual seal motors only)

Restore Performance

Original performance standards can be restored by easily replacing a worn volute seal ring

MYERS® P50 & P100 SERIES

ORDERING INFORMATION

Catalog Number	HP	Volts	Phase/Cycles	Discharge Size	Switch Type	Cord Length	Approx. Wt. Lbs.
P51	1/2	115	1/60	1-1/2"	Manual	20'	84
P51D	1/2	115	1/60	1-1/2"	Manual	20'	84
P52	1/2	230	1/60	1-1/2"	Manual	20'	84
P52D	1/2	230	1/60	1-1/2"	Manual	20'	84
P102	1	230	1/60	1-1/2"	Manual	20'	87
P102D	1	230	1/60	1-1/2"	Manual	20'	87

DIMENSIONS

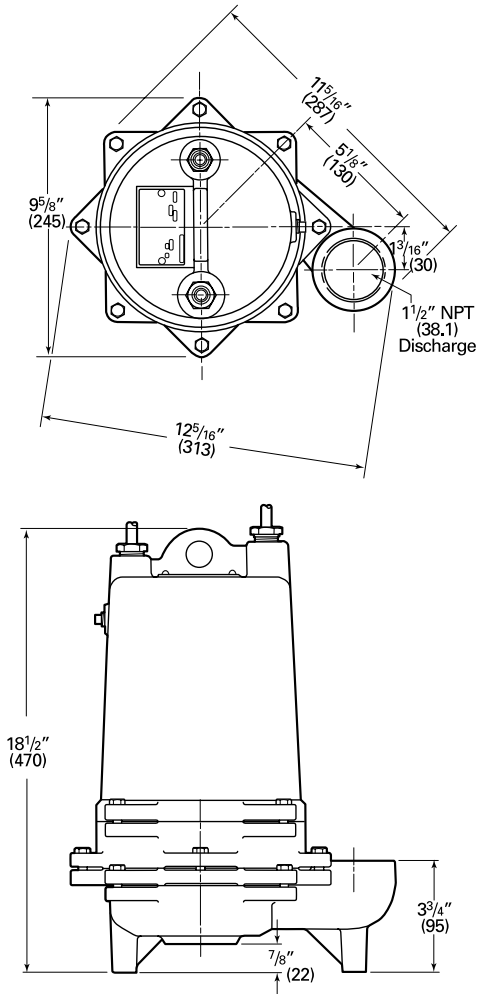

PUMP PERFORMANCE

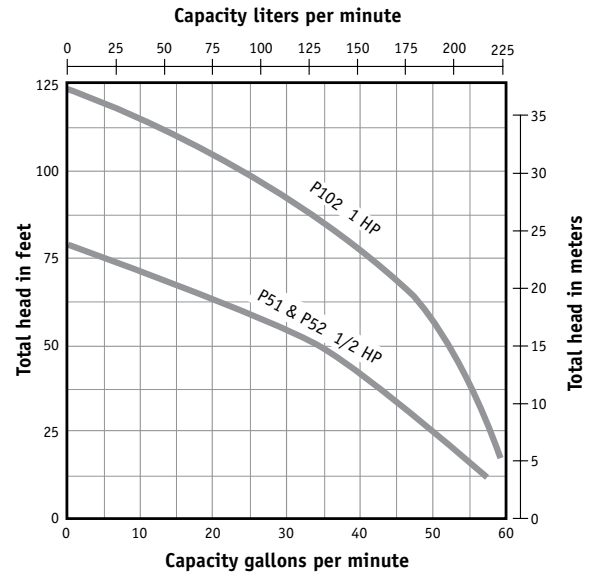

MYERS® P50 & P100 SERIES

SPECIFICATIONS

Effluent Pumps – Pump(s) shall be F. E. Myers model P series effluent pumps selected in accordance with the following design criteria:

Number of Pumps:	_____
Primary Design Flow:	_____
Primary Design Head:	_____
Minimum Shut-off Head:	80': (P51/P52) 124': (P102)
Motor Horsepower:	.5: (P51/P52) 1: (P102)
Motor Speed:	3450 RPM
Electrical:	P51: 115V, 1Ø P52/P102: 230V, 1Ø

Pump – The pump shall be designed to handle septic tank effluent and be capable of passing 3/4 inch spherical solids. The pump shall be capable of handling liquids with temperatures to 140°F intermittent and shall be capable of running dry without damage to the seals or bearings.

Motor– The pump motor shall be of the submersible type. Single phase motors shall be of the permanent split capacitor type with no relays or starting switches. Stator winding shall be of the open type with Class B insulation rated for 130°C maximum operating temperature. The winding housing will be filled with clean dielectric oil to lubricate bearings, seals, and transfer heat from the windings to the outer shell. The motor assembly shall be of the standard frame design and shall be secured in place by four threaded fasteners allowing for easy field serviceability.

The motor shall be capable of operating over the full range of the performance curve without overloading the motor and causing any objectionable noise or vibration. The motor shall have two bearings to support the rotor; an upper ball bearing to accommodate radial loads and a lower ball bearing to take thrust and radial loads. Ball bearings shall be designed for a B-10 life of 50,000 hours. A heat sensor thermostat and overload shall be attached to the top end of the motor windings and shall be wired in series with the windings to stop the motor if the motor winding temperature reaches 266°F. The overload thermostat shall reset automatically when the motor cools to a safe operating temperature.

Power Cord – The motor power cord shall be 14-3 SJOW/SJOWA or SOOW. The cable jacket shall be sealed at the motor entrance by means of a rubber compression washer and compression nut. A heat shrink tube filled with epoxy shall seal the outer cable jacket and the individual leads to prevent water from entering the motor housing.

Seal Chamber – The motor shall be protected by two (2) rotary shaft seals mounted in tandem with an oil filled chamber separating the seals. The seals shall have carbon and ceramic seal faces diamond lapped to a tolerance of one light band. Metal parts and springs for seals shall be 300 series stainless steel. Two optional electrical sensing probes shall be mounted in the seal chamber to detect any water leakage past the lower seal. The sensing probes shall be connected to a red warning light in the control panel. The warning light shall serve to indicate a seal leak and shall not stop the pump.

Pump Impeller – The pump impeller shall be of the single vane enclosed type. The impeller shall be constructed of an engineered thermoplastic. A stainless steel wear ring shall be molded into the neck of the thermoplastic impeller to provide a sealing surface. A replaceable Buna-N sealing cup shall effect a seal between the volute and impeller in order to maintain high efficiency and prevent recirculation. The impeller shall be threaded onto the 416 stainless steel pump/motor shaft.

Pump and Motor Castings – All casting shall be of high tensile strength Class 30 gray cast iron. Castings shall be treated with phosphate and chromate rinse and painted with a high quality air dry alkylid enamel.

Fasteners – All exposed fasteners shall be of 300 series stainless steel.

MYERS® P50 & P100 SERIES



USA
293 WRIGHT STREET, DELAVAN, WI 53115 WWW.FEMYERS.COM
PH: 888-987-8677 ORDERS FAX: 800-426-9446

CANADA
490 PINEBUSH ROAD, UNIT 4, CAMBRIDGE, ONTARIO N1T 0A5
PH: 800-363-7867 ORDERS FAX: 888-606-5484

Because we are continuously improving our products and services, Pentair reserves the right to change specifications without prior notice.