

MULTIQUIP INTRODUCES THE MQ600 6" WET PRIME TRASH PUMP W/HATZ TIER IV FINAL ENGINE

The **MQ600H SERIES** 6" wet priming de-watering trash pump provides the proven performance you have come to expect from Multiquip. The pump is now outfitted with a compact, powerful, and efficient HATZ 4H50 4-cylinder, turbo charged, water cooled diesel Tier IV (Final) engine. At 2,000 RPM - the pump is designed to provide 1,600 GPM Flow and 150' of Head.

★ **ISO 9001:2008 Certified - 518524**

The MQ600H Series



Model	Description	Wt. (lbs.)
MQ600H	Pump, Trash, 6", HATZ 4H50 Tier IV (F) Diesel, 1600 GPM , Skid Mounted	1,990
MQ600HTB	Pump, Trash, 6", HATZ 4H50 Tier IV (F) Diesel, 1600 GPM , Trailer Mounted - 2" Ball Hitch	2,850
MQ600HTP	Pump, Trash, 6", HATZ 4H50 Tier IV (F) Diesel, 1600 GPM , Trailer Mounted - 3" Pintle Hitch	2,850

★ Shown is the Model: MQ600HTB

Pump End Features



- **15 years of trusted design performance** the pump-end delivers 1,600 GPM FLOW and 150' HEAD.
- **Main, Front, and Intermediate Housing** constructed of grey iron #30 (tensile strength of 30,000 psi)
- **Impeller** is dynamically balanced, and is made from #45 ductile iron for strength and abrasion resistance. Handles 3" spherical solids.
- **Impeller Shaft** made from #4140 steel that exhibits hardness, operational toughness, and resistance to abrasion.
- **Mechanical Seal Assembly** is made from industrial qualified components that consists of: Tungsten Carbide Stationary and rotating face, # 304 Stainless Steel Spring & case, and Viton Rubber seals.
- **Discharge Port** provides 180° of rotational orientation, and is easily replaceable if thread damage occurs.
- **Clean Out Port** provides simple access to clear debris and foreign objects from the inner case assembly.

**THE PROVEN 6" TRASH PUMP -
POWERFUL - EFFICIENT - CLEAN**

Contact your local Multiquip District Manager: 800-421-1244



www.multiquip.com
800-421-1244

MULTIQUIP INTRODUCES THE MQ600 6" WET PRIME TRASH PUMP W/HATZ TIER IV FINAL ENGINE

Engine Features

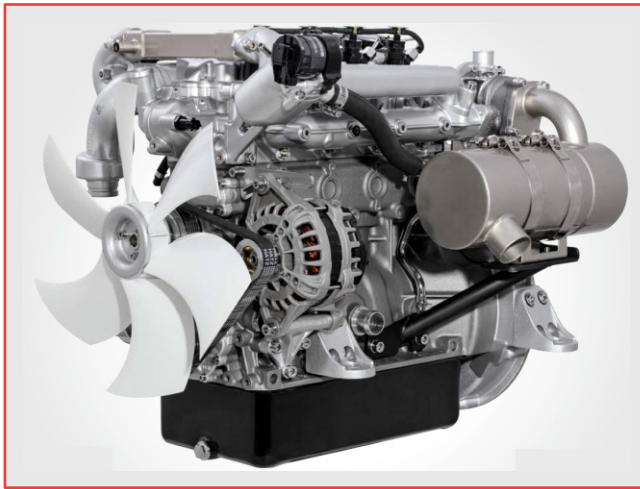

LOFA™ 620 Control Box



- HATZ model 4H50TIC 4-cylinder, Turbo charged, liquid cooled, 4-stroke diesel engine.
- A Tier IV FINAL Engine that develops 74 Horse Power.
- Supported by a BOSCH™ common rail fuel injection system, high pressure fuel pump, and provides a triple fuel filtration system.
- Engine Emissions supported by a simple Diesel Oxidation Catalyst (DOC) only.
- Fuel Consumption is @ 1.76 GPM at 2,000 RPM / Operating Sound 89 dBA at 23'.
- Engine functions controlled by the LOFA™ Model 620 graphic & analog LCD Control Box.
- Engine maintenance interval of 500 Hours.
- HATZ Engine Warranty - 5-Year / 3,000 HRS (which ever occurs first).

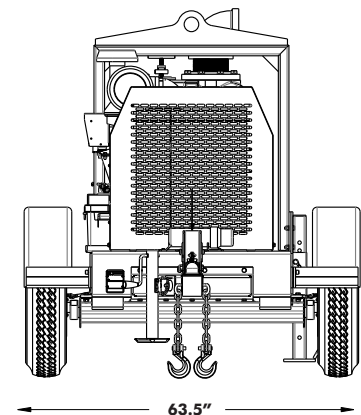
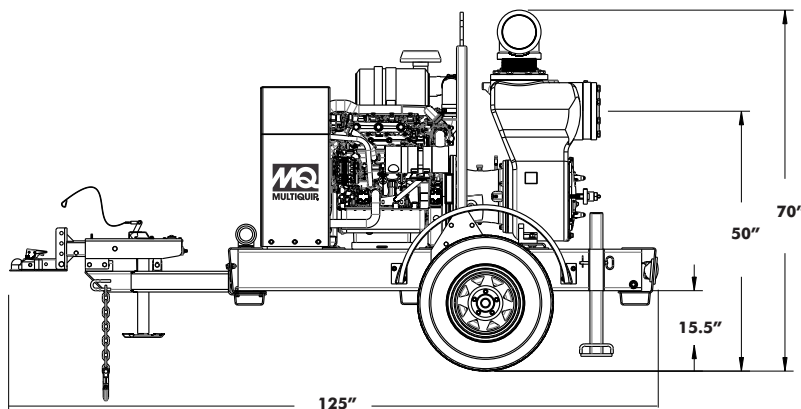

**THE PROVEN 6" TRASH PUMP -
POWERFUL - EFFICIENT - CLEAN**

Contact your local Multiquip District Manager: 800-421-1244



www.multiquip.com
800-421-1244