

Submersible Pumps & Float Switches



1 1/2XT33, 2XH5, 2X11

- **304 Stainless Steel Casing, Motor Housing, Shaft and Hardware**
- **Cast Iron Impeller, Top and Pump End**
- **Light Weight Slim Design**
- **Oil Lubricated Seals, Nitrile O-Rings**
- **Lower Seal – Silicon-Carbide, Viton®**
- **Upper Seal – Carbon Ceramic, Viton®**
- **Thermal Overload Protected**
- **1-1/2" to 2" NPT Discharge**
- **1/3 to 1 Horsepower**

Optional Piggyback Float Switch 55-930



Slim-design, light weight CSA listed submersibles feature top discharge as well as cast-iron impellers, 304 stainless steel casing, motor housing, shaft and hardware. Pump motor is thermal overload protected. An optional piggyback mercury-free float switch is available. Float Switches: The mercury free liquid level control has a piggyback plug molded to the cord allowing the pump motor to plug into the cord and then plug the entire assembly into a standard grounded outlet.

Performance of Submersible Pumps

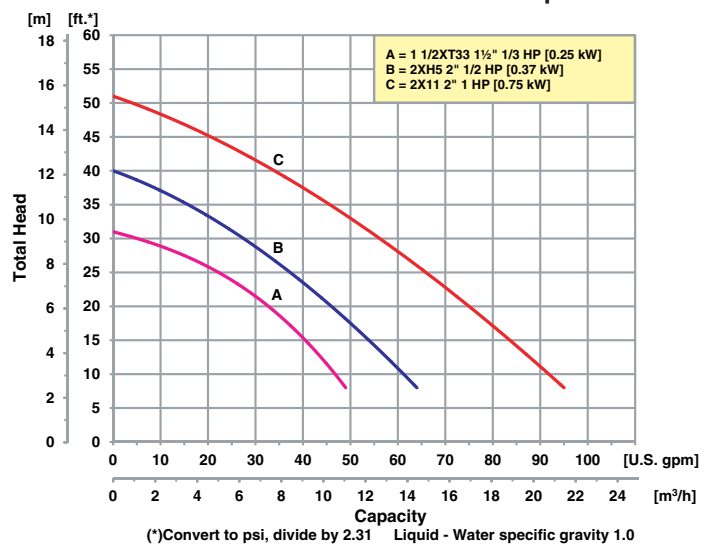

400 Spring Street • Royersford, PA 19468 USA

www.amtpump.com • 888-amt-pump (268-7867)

For use with nonflammable liquids compatible with pump component materials.

Viton® is a registered trademark of E.I. DuPont.



Submersible Pumps & Float Switches

Pump Dimensional & Specification Data

Model	Description/Type	Basic Construction	DIS*	HP	VAC	Full Load Amps	A	B	C	D Cable Length	E Suction Strainer	W	H	Ship Wt. (Lbs.)
1 1/2XT33	Submersible Pump	Stainless Steel/ Cast Iron	1-1/2	1/3	115	3	11.2 [28.5]	3.3 [8.4]	1.4 [3.5]	30 [9.1M]	0.39/[0.9] x 0.24 [0.6] Slots on 0.31/[0.7] Staggered Centers	6.6 [16.7]	14.5 [36.8]	30
2XH5	Submersible Pump	Stainless Steel/ Cast Iron	2	1/2	115	6	11.1 [28.2]	3.3 [8.4]	1.4 [3.5]	30 [9.1M]		6.6 [16.7]	14.5 [36.8]	31
2X11	Submersible Pump	Stainless Steel/ Cast Iron	2	1	115	10	13.7 [34.8]	3.8 [9.6]	1.6 [4.1]	50 [15.2M]	0.25/[0.6] x 0.38/[0.9] Slots on 0.50 [1.2] Staggered Centers	7.5 [19.0]	17.1 [43.4]	50

(*) Standard NPT (Male) pipe thread

NOTE: All dimensions are in inches (centimeters) and have a tolerance of ±1/8".

NOTE: Electric supply for ALL motors must be within ±10% of nameplate voltage rating.

(S) Minimum Liquid Height

Model	Curve	Description/Type	HP	NPT Port Size	Basic Construction	Full Load Amps
1 1/2XT33	A	Submersible Pump	1/3	1.5"	Stainless Steel/Cast Iron	3
2XH5	B	Submersible Pump	1/2	2"	Stainless Steel/Cast Iron	6
2X11	C	Submersible Pump	1	2"	Stainless Steel/Cast Iron	14

Model	Description	Ship Wt. (Lbs.)
55-930	Float Switches – Electrical Rating for 115/13 Amps with 30 Ft. 16 GA Cord	4
55-950	Float Switches – Electrical Rating for 115/20 Amps with 50 Ft. 14 GA Cord	5

Submersible Pump Standard Features

- Light Weight Slim Design
- Motors Protected by Overload or Thermal Breaker
- Lower Seal – Silicon-Carbide, Viton®
- Upper Seal – Carbon Ceramic, Viton®
- Oil Lubricated Seals
- Cast Iron Impeller, Top & Pump End
- 304 Stainless Steel Casing, Motor Housing, Shaft and Hardware
- Long Power Cables
 - 1/3 & 1/2 HP is 30 Feet in Length
 - 1 HP is 50 Feet in Length
- Optional Piggyback Mercury-free Float Switches
- Nitrile O-rings
- Max Temperature 104° F
- QSP – Quick Ship Pumps

Float Switch Standard Features

- Mercury-Free
- No Wiring
- Adjustable Clamp
- Corrosion Resistant
- Proven Reliability
- Omni Directional
- Variable Pumping Range
- Easily Installed

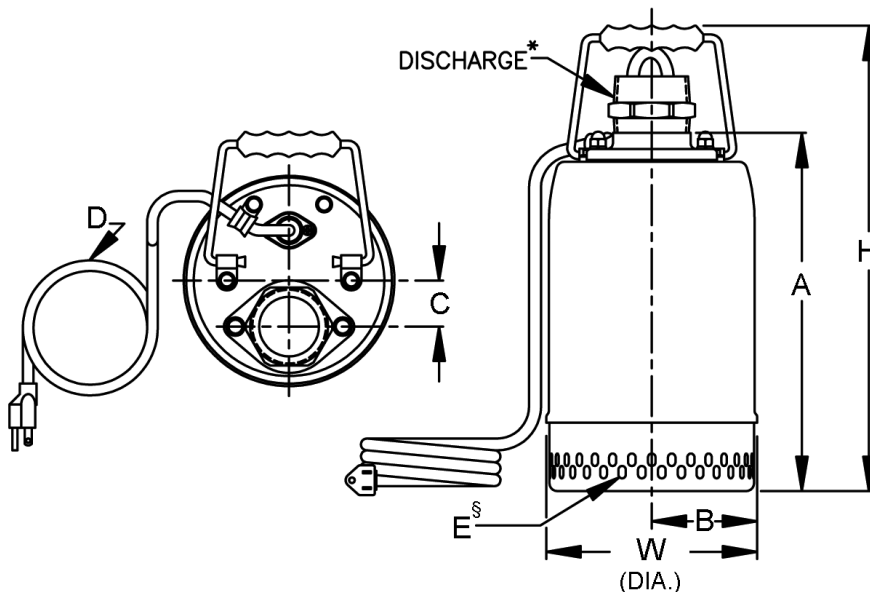

Manufacturer of AMT & IPT Pumps

400 Spring Street • Royersford, PA 19468 USA

www.amtpump.com • 888-amt-pump (268-7867)

The Gorman-Rupp Company reserves the right to discontinue any model or change specifications at any time without incurring any obligation.
©2012 American Machine and Tool Company. All rights reserved.



1212