

**INSTALLATION, OPERATION,
AND MAINTENANCE MANUAL**
WITH PARTS LIST



D SERIES PUMPS

MODELS	
3D-E1.5 1P	3D-X1.5 1P
3D-E1.5 3P	3D-X1.5 3P

GORMAN-RUPP PUMPS

www.grpumps.com

Register your new
Gorman-Rupp pump online at
www.grpumps.com

Valid serial number and e-mail address required.

RECORD YOUR PUMP MODEL AND SERIAL NUMBER

Please record your pump model and serial number in the spaces provided below. Your Gorman-Rupp distributor needs this information when you require parts or service.

Pump Model: _____

Serial Number: _____

TABLE OF CONTENTS

INTRODUCTION	PAGE I – 1
SAFETY - SECTION A	PAGE A – 1
INSTALLATION – SECTION B	PAGE B – 1
Pump Dimensions	PAGE B – 1
PREINSTALLATION INSPECTION	PAGE B – 1
POSITIONING PUMP	PAGE B – 2
Lifting	PAGE B – 2
Mounting	PAGE B – 2
SUCTION AND DISCHARGE PIPING	PAGE B – 2
Materials	PAGE B – 2
Line Configuration	PAGE B – 2
Fixed, Rigid Piping	PAGE B – 2
Gauges	PAGE B – 3
SUCTION LINES	PAGE B – 3
Fittings	PAGE B – 4
Strainers	PAGE B – 4
Sealing	PAGE B – 4
DISCHARGE LINES	PAGE B – 4
Siphoning	PAGE B – 4
Valves	PAGE B – 4
ALIGNMENT	PAGE B – 4
ELECTRICAL CONNECTIONS	PAGE B – 5
OPERATION – SECTION C	PAGE C – 1
STARTING	PAGE C – 1
OPERATION	PAGE C – 1
Priming	PAGE C – 1
OPERATION CHECKS	PAGE C – 1
Gearbox Check	PAGE C – 1
Leakage Check	PAGE C – 1
Strainer Check	PAGE C – 1
Accumulator Chamber Check	PAGE C – 1
STOPPING	PAGE C – 2
Cold Weather Preservation	PAGE C – 2
GEARBOX TEMPERATURE CHECK	PAGE C – 2
TROUBLESHOOTING – SECTION D	PAGE D – 1
PUMP MAINTENANCE AND REPAIR - SECTION E	PAGE E – 1
STANDARD PERFORMANCE CHART	PAGE E – 1
PARTS LISTS:	
Pump Model	PAGE E – 3
Diaphragm Pot Assembly	PAGE E – 5
Plunger Rod Assembly	PAGE E – 7
Gearbox Assembly	PAGE E – 9

TABLE OF CONTENTS
(continued)

PUMP AND SEAL DISASSEMBLY AND REASSEMBLY	PAGE E – 10
Suction And Discharge Check Valve Removal	PAGE E – 10
Diaphragm Removal	PAGE E – 11
Plunger Rod Removal And Disassembly	PAGE E – 11
Gearbox Removal And Disassembly	PAGE E – 11
Gearbox Reassembly And Installation	PAGE E – 13
Plunger Rod Reassembly And Installation	PAGE E – 15
Diaphragm Installation	PAGE E – 15
Suction And Discharge Check Valve Installation	PAGE E – 15
LUBRICATION	PAGE E – 16
Plunger Rod Assembly	PAGE E – 16
Gearbox	PAGE E – 16

INTRODUCTION

Thank You for purchasing a Gorman-Rupp pump. **Read this manual** carefully to learn how to safely install and operate your pump. Failure to do so could result in personal injury or damage to the pump.

Because pump installations are seldom identical, this manual cannot possibly provide detailed instructions and precautions for every aspect of each specific application. Therefore, it is the responsibility of the owner/installer of the pump to ensure that applications not addressed in this manual are performed **only** after establishing that neither operator safety nor pump integrity are compromised by the installation. Pumps and related equipment **must** be installed and operated according to all national, local and industry standards.

If there are any questions regarding the pump or its application which are not covered in this manual or in other literature accompanying this unit, please contact your Gorman-Rupp distributor, or The Gorman-Rupp Company:

The Gorman-Rupp Company
P.O. Box 1217
Mansfield, Ohio 44901—1217
Phone: (419) 755—1011
 or:
Gorman-Rupp of Canada Limited
70 Burwell Road
St. Thomas, Ontario N5P 3R7
Phone: (519) 631—2870

For information or technical assistance on the power source, contact the power source manufacturer's local dealer or representative.

HAZARD AND INSTRUCTION DEFINITIONS

The following are used to alert maintenance personnel to procedures which require special attention, to those which could damage equipment, and to those which could be dangerous to personnel:



Immediate hazards which WILL result in severe personal injury or death. These instructions describe the procedure required and the injury which will result from failure to follow the procedure.



Hazards or unsafe practices which COULD result in severe personal injury or death. These instructions describe the procedure required and the injury which could result from failure to follow the procedure.



Hazards or unsafe practices which COULD result in minor personal injury or product or property damage. These instructions describe the requirements and the possible damage which could result from failure to follow the procedure.

NOTE

Instructions to aid in installation, operation, and maintenance or which clarify a procedure.

SAFETY - SECTION A

This information applies to D Series electric motor driven diaphragm pumps. Refer to the manual accompanying the motor before attempting to begin operation.



Before attempting to open or service the pump:

1. Familiarize yourself with this manual.
2. Lock out and tag out incoming power to the motor to ensure that the pump will remain inoperative.
3. Allow the pump to completely cool if overheated.
4. Drain the pump.



This pump is designed to handle non-volatile non-flammable liquids containing specified entrained solids. Do not attempt to pump volatile, corrosive, or flammable liquids which may damage the pump or endanger personnel as a result of pump failure.



After the pump has been installed, block the wheels and secure the pump to prevent creeping. Make certain that the pump and all piping or hose connections are tight, properly supported and secure before operation.



All electrical connections must be in accordance with the National Electric Code. If there is a conflict between instructions provided and N.E.C. specifications, N.E.C. specifications shall take precedence. All electrical equipment supplied with this pump was in conformance with N.E.C. requirements in effect on the date of manufacture. Failure to follow applicable specifications, or substitution of electrical parts not supplied or approved by the manufacturer, can result in severe injury or death.



Do not operate the pump without the eccentric and coupling guards in place over the rotating parts. Exposed rotating parts can catch clothing, fingers, or tools, causing severe injury to personnel.



The electrical power used to operate this pump is high enough to cause injury or death. Obtain the services of a qualified electrician to make all electrical connections. Make certain the pump and motor are properly grounded; never use gas pipe as an electrical ground. Be sure that the incoming power matches the voltage and phase of the motor before making motor connections. Do not run the pump if the voltage is not within limits.



Do not install and operate a non-explosion proof motor in an explosive atmosphere. Install, connect, and operate the motor in accordance with The National Electric Code and all local codes. If there is a conflict between the instructions in the manual accompanying the unit and The National Electric Code or the applicable local code, The National or local code shall take precedence.



Never install a positive shut-off valve in the discharge line; discharge restrictions will cause excessive friction loss resulting in overloading and destruction of pump and drive components. It is strongly recommended that unless absolutely necessary, no positive shut-off valve be installed in the suction line; excessive restriction will cause incomplete filling of the diaphragm chamber and result in shortened diaphragm life.

INSTALLATION – SECTION B

Review all **SAFETY** information in Section A.

For further assistance, contact your Gorman-Rupp distributor or the Gorman-Rupp Company.

Since pump installations are seldom identical, this section offers only general recommendations and practices required to inspect, position, and arrange the pump and piping.

Pump Dimensions

See Figure 1 for the approximate physical dimensions of this pump.

OUTLINE DRAWING

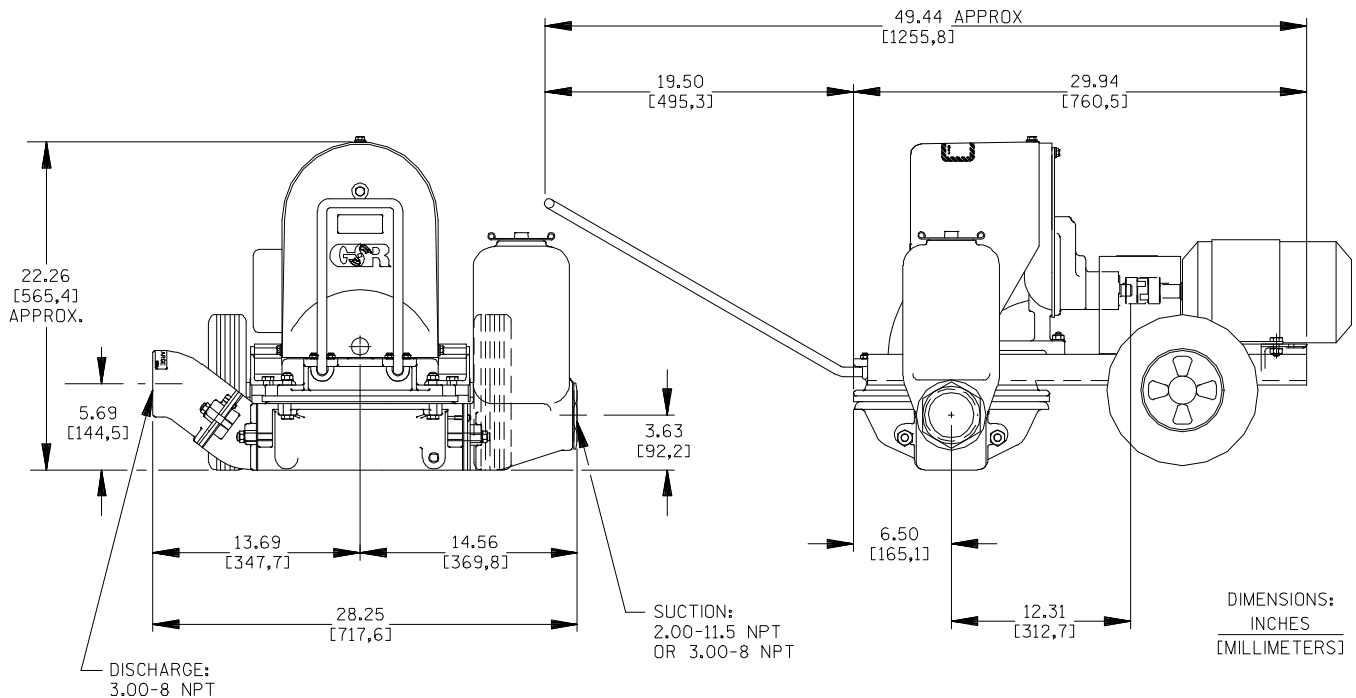

Figure 1. Pump Model 3D-E/X1.5 All Voltages

PREINSTALLATION INSPECTION

The pump assembly was inspected and tested before shipment from the factory. Before installation, inspect the pump for damage which may have occurred during shipment. Check as follows:

- Inspect the pump for cracks, dents, damaged threads, and other obvious damage.
- Check for and tighten loose attaching hardware. Since gaskets tend to shrink after drying, check for loose hardware at mating surfaces.

- Carefully read all tags, decals, and markings on the pump assembly, and perform all duties indicated.
- Check levels and lubricate as necessary. Refer to **LUBRICATION** in the **MAINTENANCE AND REPAIR** section of this manual and perform duties as instructed.
- If the pump and motor have been stored for more than 12 months, some of the components or lubricants may have exceeded their maximum shelf life. These **must be inspected**

or **replaced** to ensure maximum pump service.

If the maximum shelf life has been exceeded, or if anything appears to be abnormal, contact your Gorman-Rupp distributor or the factory to determine the repair or updating policy. **Do not** put the pump into service until appropriate action has been taken.

POSITIONING PUMP



Do not install and operate a non-explosion proof motor in an explosive atmosphere.

Lifting

Pump unit weights will vary depending on the mounting and drive provided. Check the shipping tag on the unit packaging for the actual weight, and use lifting equipment with appropriate capacity. Drain the pump and remove all customer-installed equipment such as suction and discharge hoses or piping before attempting to lift existing, installed units.



The pump assembly can be seriously damaged if the cables or chains used to lift and move the unit are improperly wrapped around the pump.

Mounting

Locate the pump in an accessible place as close as practical to the liquid being pumped. Level mounting is essential for proper operation.

The pump may have to be supported or shimmed to provide for level operation or to eliminate vibration.

After the pump has been positioned, block the wheels and secure the pump to prevent creeping.

SUCTION AND DISCHARGE PIPING

Pump performance is adversely effected by increased suction lift, discharge elevation, and friction losses. See Page E-1 to be sure your overall application allows the pump to operate within the safe operation range.

Materials

Either pipe or hose maybe used for suction and discharge lines; however, the materials must be compatible with the liquid being pumped. If hose is used in suction lines, it must be the rigid-wall, reinforced type to prevent collapse under suction. Using piping couplings in suction lines is not recommended.

Line Configuration

Keep suction and discharge lines as straight as possible to minimize friction losses. Make minimum use of elbows and fittings, which substantially increase friction loss. If elbows are necessary, use the long-radius type to minimize friction loss.

Never pull a line into place by tightening connections at the pump. Lines near the pump must be independently supported to avoid strain on the pump which could cause excessive vibration and increased diaphragm and gear train wear. If hose-type lines are used, they should have adequate support to secure them when filled with liquid and under pressure.

Fixed, Rigid Piping

This pump is equipped with an integral suction accumulator chamber which promotes an efficient flow of liquid and acts as an air cushion against shock. Since the air in this chamber will leak away during pump operation, the air must be replenished periodically. To introduce air into the chamber, stop the pump and remove the suction accumulator plug and integral gasket; this will break

prime and allow the liquid in the chamber to drain away through the suction line.

If the pump is mounted in a system with fixed, rigid piping, it is recommended that a flexible connection be installed at or near the suction and discharge ports to absorb shock which would other-

wise be transmitted through the drive train and greatly accelerate pump wear.

In a fixed piping installation, properly sized surge suppressors **must** be installed in both suction and discharge lines. If commercial surge suppressors are not readily available, air chambers may be fabricated from pipe as shown in Figure 2.

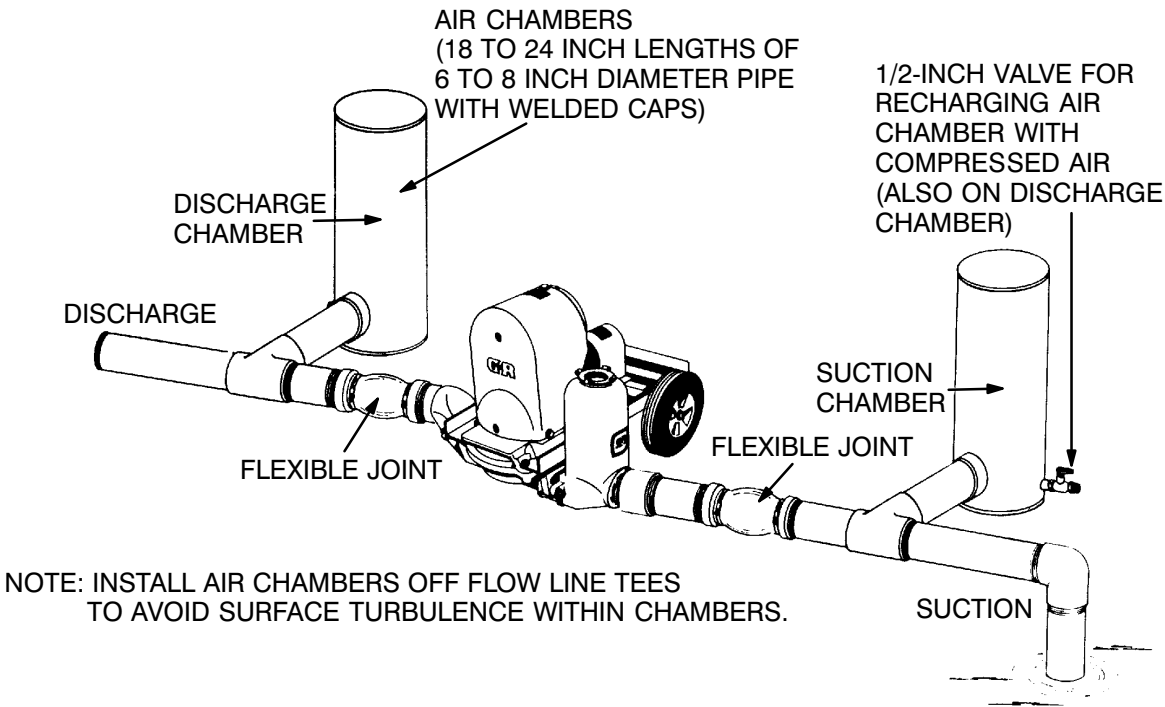

Figure 2. Fixed Piping Installation

Note that the air chambers have not been installed directly in the flow line, but have been installed off tees to avoid turbulence within the chambers. The air chambers are fitted with valves to permit introduction of small amounts of compressed air to further dampen shock; this compressed air will leak away during operation, and should be replaced from time to time. If the suction chamber floods, open the suction chamber valve to break prime and allow the liquid in chamber to drain through the suction line.

Gauges

If discharge pressure and vacuum suction gauges are desired, drill and tap the suction and discharge lines not less than 18 inches (457,2 mm) from the suction and discharge ports and install the lines.

Installation closer to the pump may result in erratic readings.

SUCTION LINES

To avoid air pockets which could affect pump priming, the suction line must be as short and direct as possible. When operation involves a suction lift, the line must always slope upward to the pump from the source of the liquid being pumped; if the line slopes down to the pump at any point along the suction run, air pockets will be created.

NOTE

Maximum pump performance is realized at suction lifts of 5 feet (1,5 m) or less. Use the shortest possible length of suction hose or piping; lengths of 25 feet (7,6 m) or longer will reduce the capacity of the pump.

It is strongly recommended that no positive shut-off valve be installed in the suction line; excessive restrictions will cause incomplete filling of the diaphragm chamber and result in short diaphragm life.

Fittings

Suction lines should be the same size as the pump inlet. If reducers are used in suction lines, they should be the eccentric type, and should be installed with the flat part of the reducers uppermost to avoid creating air pockets. The suction line should not be restricted more than 1 inch below the nominal suction size.

The use of pipe couplings in the suction line is not recommended.

Strainers

If a strainer is furnished with the pump, be certain to use it; any spherical solids which pass through a strainer furnished with the pump will also pass through the pump itself.

If a strainer is not furnished with the pump, but is installed by the pump user, make certain that the total area of the openings in the strainer is at least three or four times the cross section of the suction line, and that the openings will not permit passage of solids larger than the solids handling capability of the pump.

This pump is designed to handle up to 2-1/4 inch (57,2 mm) diameter spherical solids.

Sealing

Since even a slight leak will affect priming, head, and capacity, especially when operating with a high suction lift, all connections in the suction line should be sealed with pipe dope to ensure an airtight seal. Follow the sealant manufacturer's recommendations when selecting and applying the pipe dope. The pipe dope should be compatible with the liquid being pumped.

DISCHARGE LINES



The discharge line must be the same size as, or larger than, the suction line. Never install or operate the pump with a discharge line smaller than the suction; a restricted discharge line will cause excessive friction loss resulting in overloading and destruction of pump and drive components.

Siphoning

Do not terminate the discharge line at a level lower than that of the liquid being pumped unless a siphon breaker is used in the line. Otherwise, a siphoning action causing damage to the pump could result.

Valves

The pump is provided with integral suction and discharge check valves.



Never install a positive shut-off valve in the discharge line; discharge restrictions will cause excessive friction loss resulting in overloading and destruction of pump and drive components. It is strongly recommended that unless absolutely necessary, no positive shut-off valve be installed in the suction line; excessive restriction will cause incomplete filling of the diaphragm chamber and result in shortened diaphragm life.

ALIGNMENT

The alignment of the pump and motor is critical for trouble-free mechanical operation. The motor and pump must be mounted so that their shafts are aligned with and parallel to each other. The pump and motor were aligned and secured at the factory,

but fastening hardware may have loosened during shipment. It is imperative that alignment be checked after the pump and piping are installed, and before operation. Adjustments may be made by loosening the securing hardware and shifting or shimming components as required.

To check coupling alignment, use a feeler gauge or taper gauge between the coupling halves every 90°. The coupling is in alignment when the hubs are the same distance apart at all points.

To check parallel adjustment, lay a straightedge across both coupling halves at the top, bottom, and side. When the straightedge rests evenly on both halves of the coupling, the coupling is in horizontal parallel alignment. If the coupling is misaligned, use a feeler gauge between the coupling and the straightedge to measure the amount of misalignment.



Do not operate the pump without the eccentric and coupling guards in place over the rotating parts. Exposed rotating parts can catch clothing, fingers, or tools, causing severe injury to personnel.

ELECTRICAL CONNECTIONS

Before connecting the motor to the incoming power, check that the electrical service available

matches the pump motor requirements stamped on the motor nameplate.



The electrical power used to operate this pump is high enough to cause injury or death. Obtain the services of a qualified electrician to make all electrical connections. Make certain the pump and motor are properly grounded; never use gas pipe as an electrical ground. Be sure that the incoming power matches the voltage and phase of the motor before making motor connections. Do not run the pump if the voltage is not within limits.



Do not install and operate a non-explosion proof motor in an explosive atmosphere. Install, connect, and operate the motor in accordance with The National Electric Code and all local codes. If there is a conflict between the instructions in the manual accompanying the unit and The National Electric Code or the applicable local code, The National or local code shall take precedence.

Refer to the following motor data before making electrical connections.

Motor Data

MODEL	VOLTAGE	PHASE	HP	Hz	RPM	THERMAL OVERLOAD
3D-E1.5	115/230	1	1.5	60	1800	N/A
	230/460	3	1.5	60	1800	N/A
3D-X1.5	115/230	1	1.5	60	1800	YES
	230/460	3	1.5	60	1800	YES

OPERATION – SECTION C

Review all **SAFETY** information in Section A.

Follow the instructions on all tags, labels and decals attached to the pump.



This pump is designed to handle **non-volatile non-flammable liquids containing specified entrained solids**. Do not attempt to pump **volatile, corrosive, or flammable liquids** which may damage the pump or endanger personnel as a result of pump failure.



After the pump has been installed, **block the wheels and secure the pump to prevent creeping**. Make certain that the **pump and all piping or hose connections are tight, properly supported and secure before operation**.

Pump application will affect its performance, especially discharge velocities. Consult the Gorman-Rupp factory for actual performance levels for the pump.

Install the pump and piping as described in **INSTALLATION**. Make sure that the piping connections are tight, and that the pump is securely mounted. Check that components are properly lubricated (see **LUBRICATION** in **MAINTENANCE AND REPAIR**).



Make certain that any positive shut-off valve installed in the suction line is open before operating the pump; excessive re-

striction will cause incomplete filling of the diaphragm chamber and result in shortened diaphragm life. No positive shut-off valve should be installed in the discharge line.

STARTING

Consult the operations manual furnished with the motor before starting the pump. Open any valves installed in the suction line and start the pump.

OPERATION



The pump is designed to operate at approximately 60 cycles per minute through a gearbox with a 30.36:1 ratio at a maximum input speed of 1800 RPM. Make certain that the electric motor installed does not exceed this RPM. Operation at higher RPM can cause pump components to be damaged or destroyed.

Priming

The pump may not prime immediately because the suction line must first fill with liquid. If the pump fails to prime within five minutes, stop the engine and check the suction line for leaks.

OPERATION CHECKS

Gearbox Check

Check that the gearbox is properly lubricated (see **LUBRICATION** in **MAINTENANCE AND REPAIR**).

Leakage Check

No leakage should be visible at pump mating surfaces, connections or fittings. Keep all line connections and fittings tight to maintain maximum pump efficiency.

Strainer Check

If a suction strainer has been installed, check and clean it as necessary. It should be cleaned if pump flow begins to drop. If a vacuum suction gauge has been installed, monitor and record the readings regularly to detect strainer blockage.

Accumulator Chamber Check

Check periodically to ensure that there is sufficient air in the integral suction accumulator chamber. Replenish as required (see **Fixed, Rigid Piping** in Section B for details).

STOPPING

After stopping the pump, lock out and tag out incoming power to the motor to ensure that the pump will remain inoperative.

If the pump will be idle for more than a few hours, or if it has been pumping liquids containing a large amount of solids, flush it with clean water.

Cold Weather Preservation



The primary construction materials of this pump are aluminum, with neoprene flap valves and a **DuraBlue 1000™** diaphragm. Do not attempt to clean or flush this pump with any liquid which would attack pump fittings or components. Avoid cleaning with cleaning solvent.

In below freezing conditions, drain the water from the pump and the lines when the pump is not in operation. Also, clean out any solids by flushing with a hose.

GEARBOX TEMPERATURE CHECK

The gearbox runs higher than ambient temperatures because of heat generated by friction. Temperatures of approximately 200°F (93°C) are considered normal, and can operate intermittently at 250°F (121°C).

Checking gearbox temperatures by hand is inaccurate. Place a contact-type thermometer against the housing and record this temperature for future reference.

A sudden increase in gearbox temperature is a warning that the bearings are at the point of failing. Make certain that the bearing lubricant is of the proper viscosity and at the correct level (see **LUBRICATION** in Section E). Bearing overheating can also be caused by shaft misalignment and/or excessive vibration.

When pumps are first started, the bearings may seem to run at temperatures above normal. Continued operation should bring the temperatures down to normal levels.

TROUBLESHOOTING – SECTION D

Review all SAFETY information in Section A.



Before attempting to open or service the pump:

- 1. Familiarize yourself with this manual.**
- 2. Lock out and tag out incoming power to ensure that the pump will remain inoperative.**
- 3. Allow the pump to completely cool if overheated.**
- 4. Drain the pump.**

TROUBLE	POSSIBLE CAUSE	PROBABLE REMEDY
PUMP FAILS TO PRIME	<p>Air leak in suction line.</p> <p>Lining of suction hose collapsed.</p> <p>Integral suction or discharge check valve clogged, binding, or not seating properly.</p> <p>Cracked or broken diaphragm.</p> <p>Diaphragm not securely in place.</p> <p>Strainer clogged.</p>	<p>Correct leak.</p> <p>Replace suction hose.</p> <p>Clean valves, check that flange nuts are tight.</p> <p>Replace diaphragm.</p> <p>Secure diaphragm.</p> <p>Check strainer and clean if necessary</p>
PUMP STOPS OR FAILS TO DELIVER RATED FLOW OR PRESSURE	<p>Air leak in suction line.</p> <p>Suction intake not properly submerged</p> <p>Lining of suction hose collapsed.</p> <p>Cracked or broken diaphragm.</p> <p>Diaphragm not securely in place.</p> <p>Strainer clogged.</p> <p>Integral suction or discharge check valve clogged, binding, or not seating properly.</p>	<p>Correct leak.</p> <p>Check installation.</p> <p>Replace suction hose.</p> <p>Replace diaphragm.</p> <p>Secure diaphragm.</p> <p>Check strainer and clean if necessary</p> <p>Clean valves, check that flange nuts are tight.</p>

TROUBLE	POSSIBLE CAUSE	PROBABLE REMEDY
PUMP REQUIRES TOO MUCH POWER	<p>Liquid solution too thick.</p> <p>Integral discharge check valve clogged or binding.</p> <p>Bearings in motor or gearbox worn or binding.</p>	<p>Dilute if possible.</p> <p>Clean valve.</p> <p>Check bearings.</p>
PUMP CLOGS FREQUENTLY	<p>Integral suction or discharge check valve clogged, binding, or not seating properly.</p> <p>Liquid solution too thick.</p>	<p>Clean valves, check that flange nuts are tight.</p> <p>Dilute if possible.</p>
EXCESSIVE NOISE	<p>Pump, gearbox, or motor not securely mounted.</p> <p>Gearbox or motor not properly lubricated.</p>	<p>Check and tighten mounting bolts.</p> <p>See LUBRICATION in MAINTENANCE AND REPAIR.</p>
BEARINGS RUN TOO HOT	<p>Bearing temperature is high, but within limits.</p> <p>Low or incorrect lubricant.</p> <p>Drive misaligned.</p>	<p>Check bearing temperature regularly to monitor any increase.</p> <p>Check for proper type and level of lubricant.</p> <p>Align drive properly.</p>

PUMP MAINTENANCE AND REPAIR - SECTION E

MAINTENANCE AND REPAIR OF THE WEARING PARTS OF THE PUMP WILL MAINTAIN PEAK OPERATING PERFORMANCE.

IN GALLONS PER MINUTE AT 60 STROKES PER MINUTE				
STATIC LIFT IN FEET	STATIC DISCHARGE HEAD IN FEET			
	5	10	15	20
5	78	67	66	68
10	73	64	66	62
15	68	60	64	59
20	64	59	65	59
25	56	56	60	56

IN LITERS PER MINUTE AT 60 STROKES PER MINUTE				
STATIC LIFT IN METERS	STATIC DISCHARGE HEAD IN METERS			
	1,5	3,0	4,6	6,1
1,5	295,2	253,6	249,8	257,4
3,0	276,3	242,2	249,8	234,7
4,6	257,4	227,1	242,2	223,3
6,1	242,2	223,3	246,0	223,3
7,6	212,0	212,0	227,1	212,0

*** STANDARD PERFORMANCE TEST DATA FOR 3D ELECTRIC MOTOR DRIVEN PUMP**

* Based on 70°F (21°C) clear water at sea level with minimum suction lift, using 3 inch (7,62 cm) suction hose and 4 inch (10,16 cm) non-collapsible discharge hose. Since pump installations are seldom identical, your performance may be difference due to such factors as viscosity, specific grav-

ity, elevation, temperature, and impeller trim.

If your pump serial number is followed by an "N", your pump is **NOT** a standard production model. Contact the Gorman-Rupp Company to verify performance or part numbers.

SECTION DRAWING

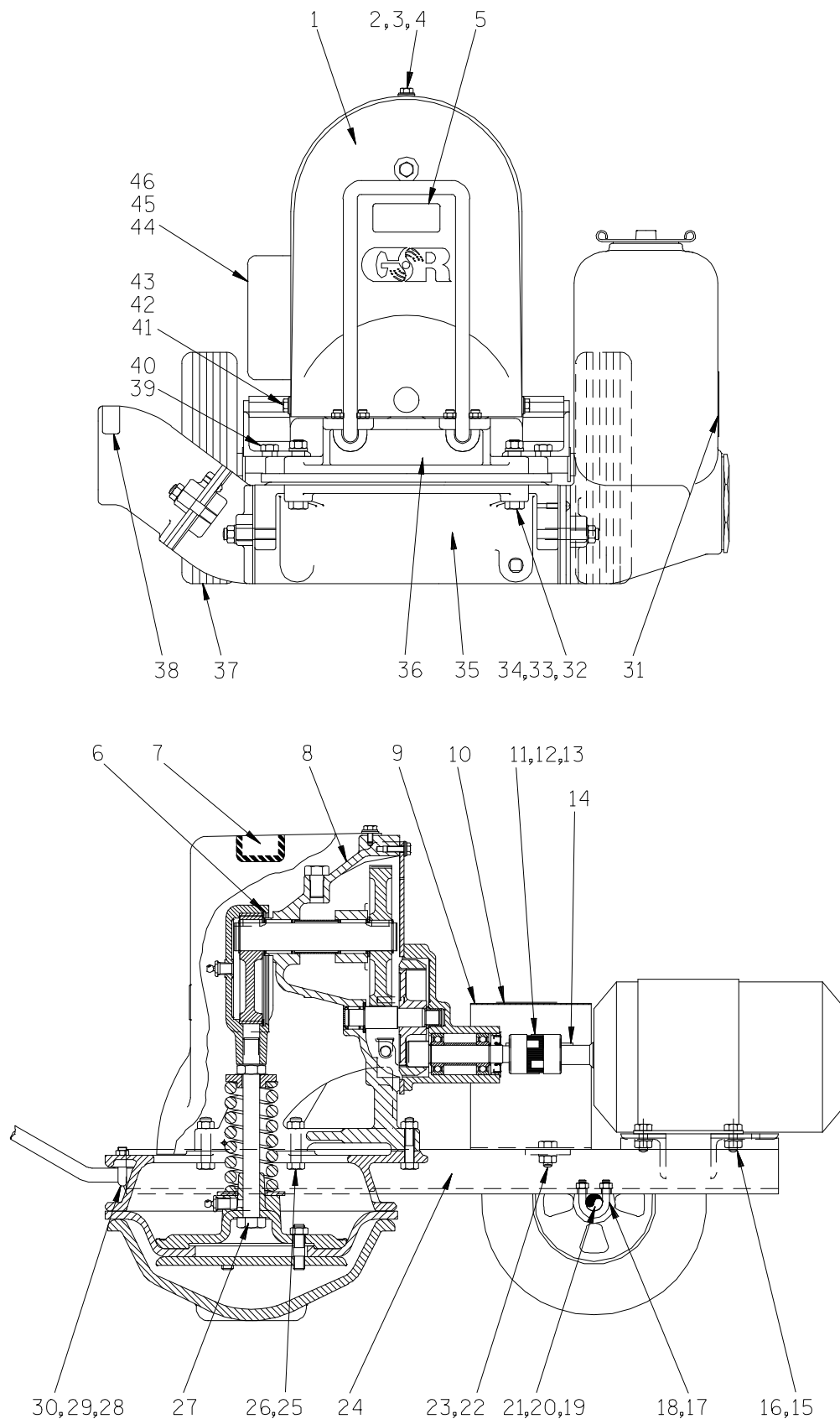

Figure 1. 3D Electric Motor Driven Pump

PARTS LIST
Pump Models 3D-E1.5 1P , 3D-E1.5 3P,
3D-X1.5 1P And 3D-X1.5 3P
 (From S/N 883504 up)

If your pump serial number is followed by an "N", your pump is **NOT** a standard production model. Contact the Gorman-Rupp Company to verify part numbers.

ITEM NO.	PART NAME	PART NUMBER	QTY	ITEM NO.	PART NAME	PART NUMBER	QTY
1	ECCENTRIC GUARD	38861-501 23200	1	29	U-BOLT	5495 15991	2
2	NYLOCK CAPSCREW	BT0403 15991	1	30	FLANGED HEX NUT	21765-314	4
3 *	WASHER	S157	1	31	SUCTION STICKER	6588AG	1
4	FLAT WASHER	K04 15991	1	32	FLAT WASHER	K08 15991	4
5	LUBRICATION DECAL	38817-066	1	33	HEX NUT	D08 15991	4
6	SNAP RING	5385	1	34	HEX HD CAPSCREW	B0811 15991	4
7	GUARD WARNING DECAL	38816-063	1	35	DIAPHRAGM POT ASSY	46475-701	1
8	GEAR BOX ASSY	8981	1	36	DIAPHRAGM RING	13582 13010	1
9	COUPLING GUARD	34613-005 15020	1	37 *	PNEUMATIC WHEEL	S752	2
10	GUARD WARNING DECAL	38816-063	1	38	DISCHARGE STICKER	6588BJ	1
11	3/4" COUPLING HALF	24355-035	1	39	HEX HD CAPSCREW	B0604 15991	2
12	7/8" COUPLING HALF	24355-037	1	40	LOCKWASHER	J06 15991	2
13	SPIDER	24355-262	1	41	HEX HD CAPSCREW	B0402 1/2 15991	2
14	KEY	N0304 15990	1	42	T TYPE LOCKWASHER	AK04 15991	2
15	HEX HD CAPSCREW	B0504 15991	4	43	FLAT WASHER	K04 15991	2
16	FLANGED HEX NUT	21765-312	4	44	MOTOR X1.5 HP 1P	28274-040	1
17	U-BOLT	5495 15991	2		MOTOR X1.5 HP 3P	28274-442	1
18	FLANGED HEX NUT	21765-314	4		MOTOR E1.5 HP 1P	28214-040	1
19	AXLE	4607AD 15990	1		MOTOR E1.5 HP 3P	28214-442	1
20	SPACE WASHER	5382 15990	4	45	WARNING DECAL	2613FF	1
21	HAIRCLIP PIN	21183-010	4	46	WARNING DECAL	2613FE	1
22	HEX HD CAPSCREW	B0403 15991	2		NOT SHOWN:		
23	FLANGED HEX NUT	21765-310	2		NAME PLATE	2613BP 13990	1
24	BASE	13583 24000	1		DRIVE SCREW	BM#04-03 15990	4
25	HEX HD CAPSCREW	B0608 15991	5		STRAINER	4917 24001	1
26	FLANGED HEX NUT	21765-314	5		TRADEMARK DECAL	38812-049	1
27	PLUNGER ROD ASSY	5685	1		OPTIONAL:		
28	DRAW BAR	5438 15990	1		STATIONARY BASE	8105B 24000	1

* INDICATES PARTS RECOMMENDED FOR STOCK

SECTION DRAWING

NOTE:

FLAP VALVE ASSEMBLY;
 SHOWN IN POSITION ON DISCHARGE SIDE
 SUCTION SIDE TO OPEN IN SAME DIRECTION.

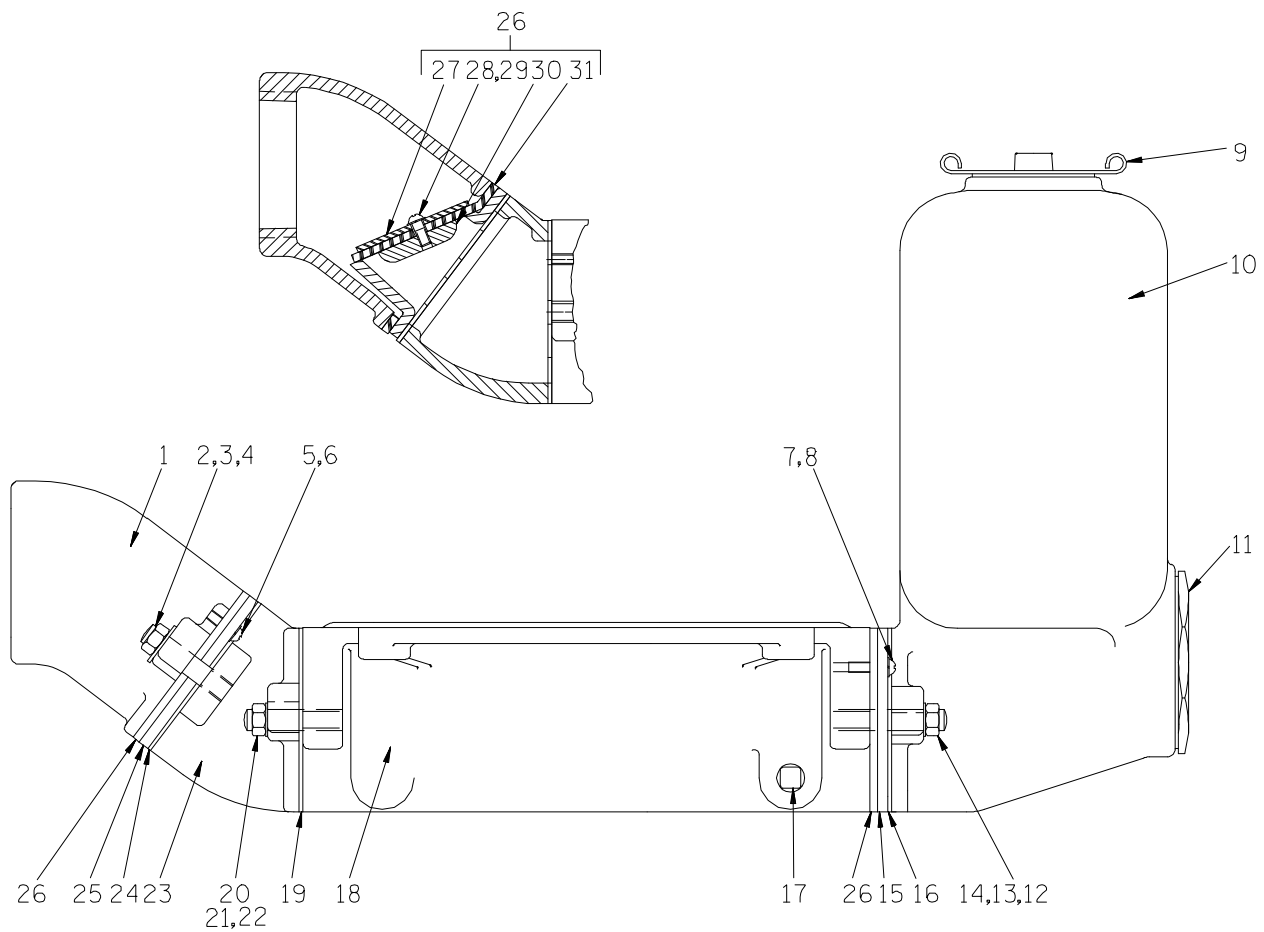

Figure 2. 46475-701 Diaphragm Pot Assembly

PARTS LIST
46475-701 Diaphragm Pot Assembly

ITEM NO.	PART NAME	PART NUMBER	QTY
1	DISCHARGE FLANGE	5658 13040	1
2	STUD	C0810 15991	2
3	HEX NUT	D08 15991	2
4	FLAT WASHER	KE08 15991	2
5	RD HD MACHINE SCREW	X0404 15991	2
6	LOCKWASHER	J04 15991	2
7	RD HD MACHINE SCREW	X0404 15991	2
8	LOCKWASHER	J04 15991	2
9	DRUM PLUG with GASKET	25142-010	1
10	SUCTION STUB	5376 13010	1
11	RED PIPE BUSHING	AP4832 11999	1
12	STUD	C0810 15991	2
13	FLAT WASHER	K07 15991	2
14	HEX NUT	D08 15991	2
15	VALVE SEAT	5374 10010	1
16	* GASKET	5374G 19100	1
17	DIAPHRAGM POT DRAIN PLUG	P06 15079	1
18	DIAPHRAGM POT	5375 13010	1
19	* GASKET	5374G 19100	1
20	STUD	C0809 15991	2
21	FLAT WASHER	K07 15991	2
22	HEX NUT	D08 15991	2
23	DISCHARGE FLANGE	5377 13040	1
24	* GASKET	5374G 19100	1
25	VALVE SEAT	5374 10010	1
26	FLAP VALVE ASSY	46413-013	1
27	-VALVE WEIGHT	5428 15990	1
28	-RD HD MACHINE SCREW	X0403 17000	4
29	-LOCKWASHER	J04 17000	4
30	-VALVE WEIGHT	5426 13010	1
31	* -FLAP VALVE	5427 19100	1

* INDICATES PARTS RECOMMENDED FOR STOCK

SECTION DRAWING

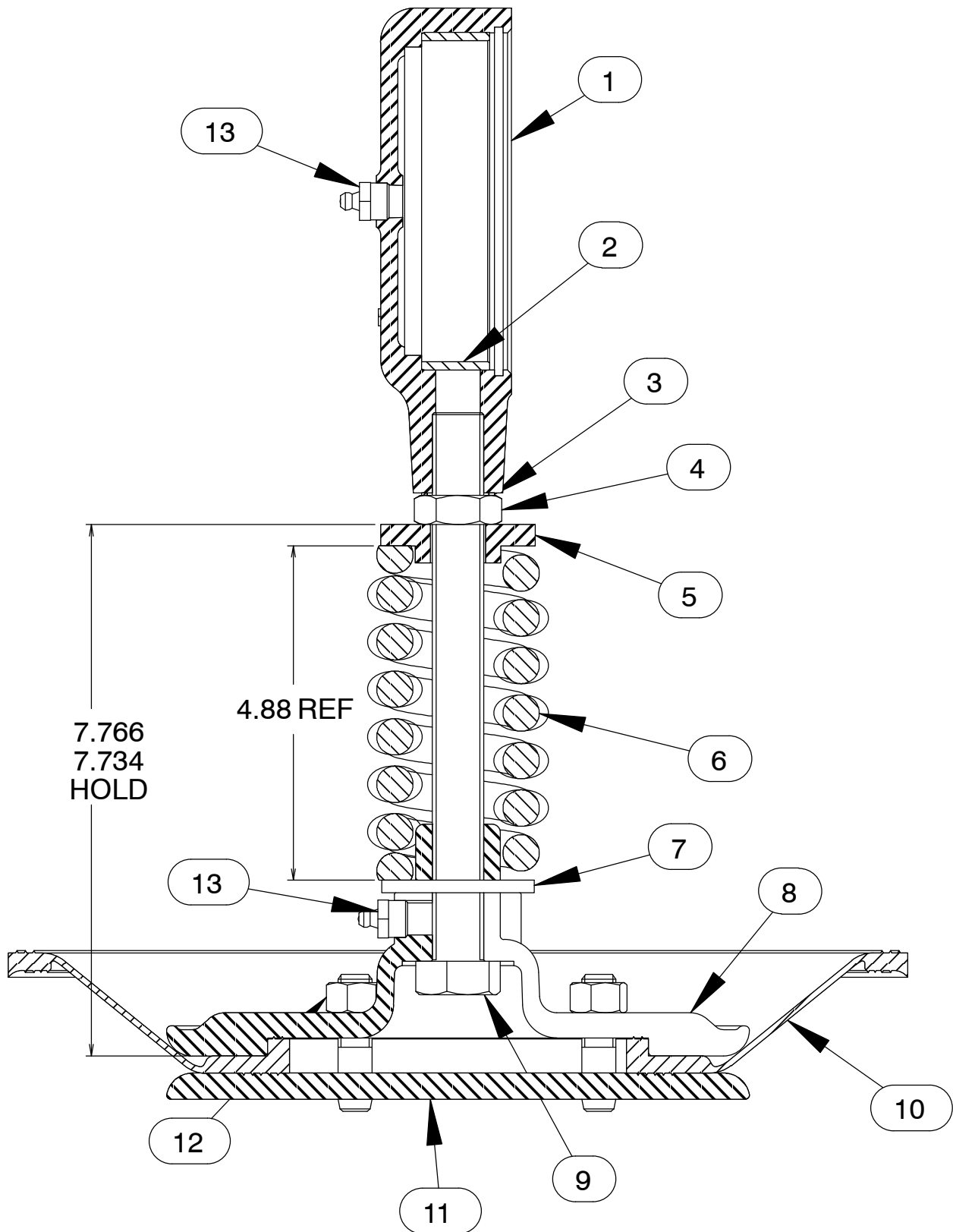

Figure 3. 5685 Plunger Rod Assembly

PARTS LIST
5685 Plunger Rod Assembly

ITEM NO.	PART NAME	PART NUMBER	QTY
1	ECCENTRIC CAP	5373 13010	1
2	BEARING – ECCENTRIC	5610 14000	1
3	T-TYPE LOCKWASHER – 3/4"	AK12 15991	1
4	HEX JAM NUT	AT12 15991	1
5	SPRING WASHER	5384 15991	1
6	* SPRING	5398 16081	1
7	FLAT WASHER	K20 15991	1
8	DIAPHRAGM PLATE	5381 10010	1
9	HEX BOLT	21612-577	1
10	* DIAPHRAGM	26844-041	1
11	DIAPHRAGM PLATE ASSY	5394	1
12	HEX NUT	D08 15991	3
13	LUBE FITTING	S191	2

* INDICATES PARTS RECOMMENDED FOR STOCK

SECTION DRAWING

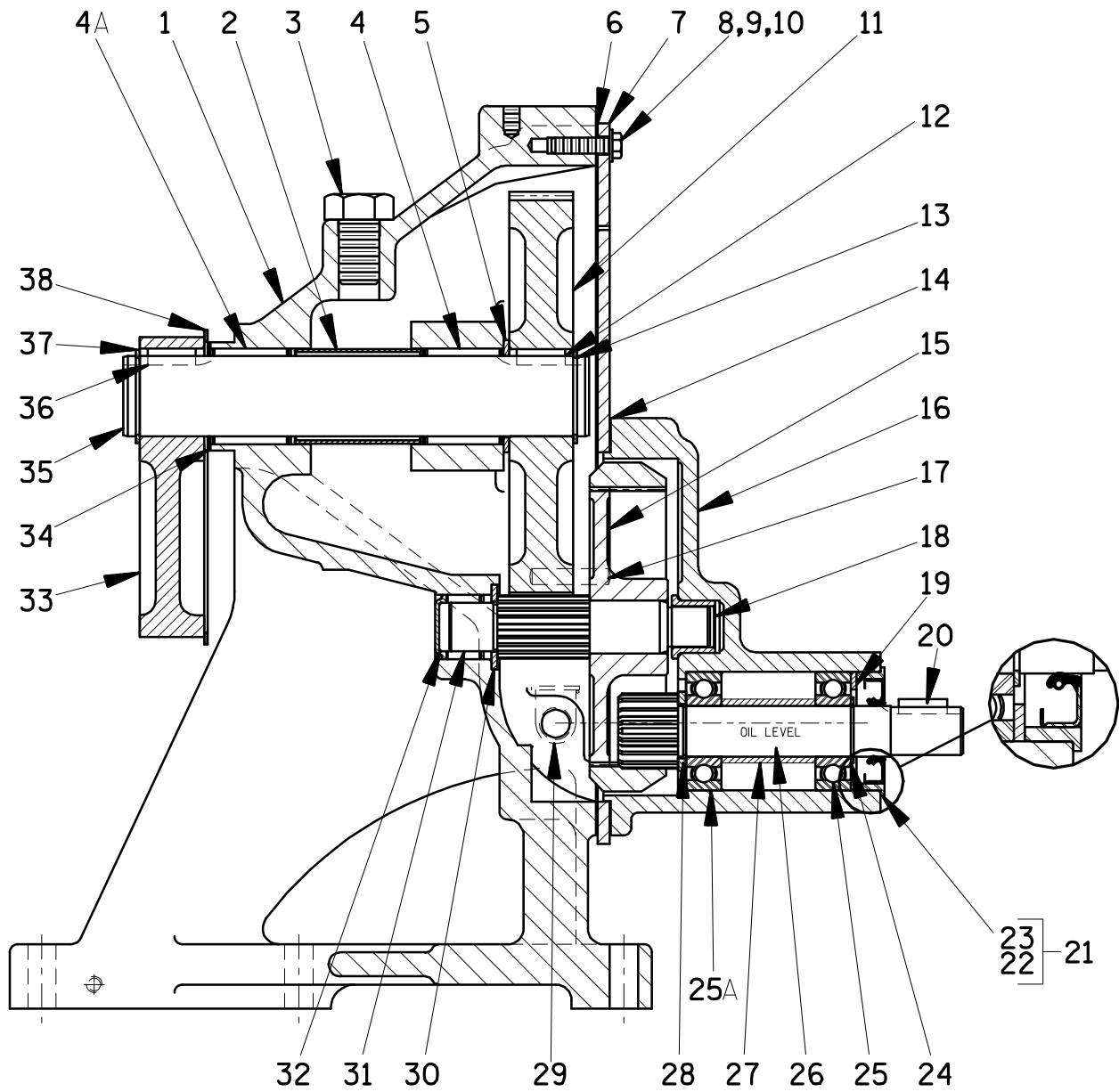

Figure 4. 8981 Gearbox Assembly

PARTS LIST
8981 Gearbox Assembly

ITEM NO.	PART NAME	PART NUMBER	MAT'L CODE	QTY	ITEM NO.	PART NAME	PART NUMBER	MAT'L CODE	QTY
1	GEAR HOUSING	5367	13010	1	20 *	KEY	N0304	15990	1
2	SPACER SLEEVE	S952	----	1	21 *	OIL SEAL ASSY	14408	----	1
3	HEX HD CAPSCREW	B1004	15991	1	22	-OIL SEAL ADAPTER	14407	15000	1
4	BEARING	S702	----	1	23	-OIL SEAL	25227-355	----	1
4A	BEARING	S702	----	1	24 *	SNAP RING	S269	----	1
5	SPACER WASHER	5395	15990	1	25 *	BALL BEARING	S1044	----	1
6 *	HOUSING GSKT	5367G	18000	1	25A *	BALL BEARING	S1044	----	1
7	COVER PLATE	5396	13010	1	26	DRIVE PINION	5917	16070	1
8	HEX HD CAPSCREW	B0403	15991	7	27	SLEEVE	5922	15070	1
9	LOCKWASHER	J04	15991	9	28	WASHER	5921	15990	1
10	HEX HD CAPSCREW	B0407	15991	2	29	OIL CUP	S617	----	1
11 *	GEAR	5334	16060	1	30	SPACER WASHER	5382	15991	1
12 *	HARDENED KEY	24113-542	----	1	31	PINION	5333	16020	1
13 *	SNAP RING	S700	----	1	32	BEARING	S703	----	1
14	GASKET	S825	----	1	33	ECCENTRIC CAM	5378A	10080	1
15	INTERNAL GEAR	S823	----	1	34	ADJ SHIM SET	13103A	15990	1
16	BEARING HOUSING	5918	13010	1	35	DRIVE SHAFT	5397	15020	1
17	STR DOWEL PIN	AA0405	15990	2	36	HARDENED KEY	31811-040	15990	1
18 *	PINION BRG BUSH	S824	----	1	37	SNAP RING	S700	----	1
19	WASHER	2M	15990	3	38	WASHER	6531	18040	1

* INDICATES PARTS RECOMMENDED FOR STOCK

PUMP DISASSEMBLY AND REASSEMBLY

Review all SAFETY information in Section A.

Follow the instructions on all tags, label and decals attached to the pump.

This pump requires little service due to its rugged, minimum-maintenance design. However, if it becomes necessary to inspect or replace the wearing parts, follow these instructions which are keyed to the sectional views (see Figures 1, 2, 3 and 4) and the accompanying parts lists.

Before attempting to service the pump, lock out and tag out incoming power to the motor to ensure that it will remain inoperative. Close all valves in the suction and discharge lines.

For motor disassembly and repair, consult the literature supplied with the motor, or contact your local motor representative.

Most service functions may be performed without separating the pump and gearbox from the motor. If major repair is required, the pump, gearbox and motor must be disconnected.



Before attempting to open or service the pump:

1. Familiarize yourself with this manual.
2. Lock out and tag out incoming power to the motor to ensure that the pump will remain inoperative.
3. Allow the pump to completely cool if overheated.
4. Drain the pump.

Before attempting to service the pump, drain the pump by removing the drain plug (18, Figure 2). Clean and reinstall the drain plug.



Use **Only Genuine Gorman-Rupp** replacement parts. Failure to do so may create a hazard and damage the pump or diminish optimal pump performance. Any such hazard, damage or diminished performance is not covered by the warranty.

NOTE

When appropriate recycling facilities are available, the user should recycle components and fluids when doing any routine maintenance / repairs and also at the end of the pump's useful life. All other components and fluids shall be disposed of according to all applicable codes and regulations.

Suction And Discharge Check Valve Removal (Figure 2)

To service the suction and discharge check valves, remove the suction and discharge piping.

To service the suction check valve assembly (26), remove the suction accumulator (10) by removing the hardware (13 and 14) securing it to the diaphragm pot (18). Remove the hardware (7 and 8) securing the valve seat (15) and check valve assembly to the diaphragm pot. Pull the check valve assembly from the suction port.

To service the discharge check valve assembly (26), loosen the hardware (3 and 4) and remove the assembled discharge flange (1), valve seat (25) and check valve assembly. Remove the gasket (24).

Remove the hardware (5 and 6) securing the valve seat and discharge check valve assembly to the discharge elbow.

To remove the discharge flange (23), loosen the hardware (21 and 22) securing the flange to the diaphragm pot. Remove the gasket (19).

The suction and discharge check valve assemblies are identical parts and operate in the same direction. For removal and/or replacement, remove the hardware (28 and 29) securing the check valve

weights (27 and 30) to the check valve (31). Inspect and replace parts as required.

If no further disassembly is required, see **Suction And Discharge Check Valve Installation**.

Diaphragm Removal

(Figure 1)

To remove the diaphragm (10, Figure 3), disengage the hardware (32, 33 and 34) and remove the diaphragm pot assembly (35). Inspect the diaphragm ring (36) for wear or damage. If replacement is required, the gearbox assembly (8) must be removed.

(Figure 3)

Remove the nuts (12). Separate the lower diaphragm plate assembly (11) from the diaphragm (10) and the upper diaphragm plate (8). Inspect the diaphragm and replace as required.

If no further disassembly is required, see **Diaphragm Installation**.

Plunger Rod Removal And Disassembly

(Figure 1)

With the diaphragm pot assembly and diaphragm removed, disengage the hardware (2, 3, 4, 41, 42 and 43) and remove the eccentric guard (1).

Removing the snap ring (6) and slide the plunger rod assembly (27) off the eccentric cam (33, Figure 4).

(Figure 3)

Use a socket wrench to hold the plunger rod (14) securely and unscrew the eccentric cap (1). Remove the T-type lockwasher (3), jam nut (4), spring washer (5) and spring (6). Remove the flat washer (7) and slide the plunger rod out of the upper diaphragm plate (8).

Inspect the eccentric bearing (2) for excessive wear. If replacement is necessary, use a suitable tool to cut the bearing and remove it from the eccentric cap. **Be careful** not to damage the eccentric cap.

Gearbox Removal And Disassembly

(Figure 1)

When properly operated and maintained, the gearbox assembly (8) should not require disassembly. Disassemble the gearbox **only** when there is evidence of wear or damage.



Shaft and bearing disassembly in the field is not recommended. These operations should be performed only in a properly equipped shop by qualified personnel.

Support the diaphragm ring (36) with wooden blocks. Disengage the hardware (25 and 26) securing the gearbox to the diaphragm ring, and remove the diaphragm ring. Inspect the diaphragm ring for wear or damage and replace as necessary. It is not necessary to remove the drawbar (28) from the diaphragm ring unless replacement is required. Disengage the hardware (30) from the U-bolts (29) to remove the drawbar.

Disengage the hardware (22 and 23) and remove the coupling guard (9). Loosen the attaching hardware, separate the coupling halves (11 and 12) and remove the spider (13). Remove the gearbox assembly, and slide the coupling half off the pinion drive shaft (26, Figure 4).

(Figure 4)

Before attempting to disassemble the gearbox assembly, drain the lubricant by removing the oil cup (29) and turning the gearbox on its side. Clean and reinstall the oil cup.

Remove the two lower and the five upper pieces of hardware (8, 9 and 10) securing the cover plate (7) to the gear housing (1). Pull the bearing housing (16) and cover plate from the pinion shaft (31) and gear (15). Remove the gasket (6) and clean the mating surfaces. Replace the gasket as necessary.

Remove the remaining two pieces of hardware (9 and 10) and separate the cover plate from the bearing housing. Remove the gasket (14) and clean the mating surfaces. Replace the gasket as necessary.

To disassemble the pinion drive shaft components, remove the key (20) and pry the oil seal assembly

(21) from the bearing housing. Press the oil seal (23) from the seal adaptor (22).

Remove the washer (19) and slide the assembled pinion drive shaft (26), bearings (25 and 25A) and sleeve (27) from the bearing housing.

After removing the shaft and bearings, clean and inspect the bearings **in place** as follows.

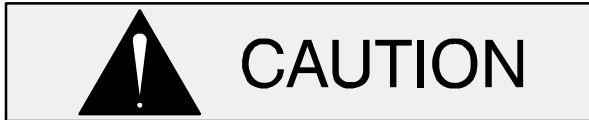

To prevent damage during removal from the shaft, it is recommended that bearings be cleaned and inspected **in place**. It is **strongly** recommended that the bearings be replaced **any** time the shaft and bearings are removed.

Clean the bearing housing, shaft and all component parts (except the bearings) with a soft cloth soaked in cleaning solvent. Inspect the parts for wear or damage and replace as necessary.



Most cleaning solvents are toxic and flammable. Use them only in a well-ventilated area free from excessive heat, sparks, and flame. Read and follow all precautions printed on solvent containers.

Clean the bearings thoroughly in **fresh** cleaning solvent. Dry the bearings with filtered compressed air and coat with light oil.



Bearings must be kept free of all dirt and foreign material. Failure to do so will greatly shorten bearing life. **Do not** spin dry bearings. This may scratch the balls or races and cause premature bearing failure.

Rotate the bearings by hand to check for roughness or binding and inspect the bearing balls. If ro-

tation is rough or the bearing balls are discolored, replace the bearings.

The bearing tolerances provide a tight press fit onto the shaft and a snug slip fit into the bearing housing. Replace the bearings, shaft, or bearing housing if the proper bearing fit is not achieved.

Inspect the sleeve (27) and replace as necessary.

If bearing and sleeve replacement is required, remove the snap ring (24). Using a bearing puller, remove the outboard bearing (25) from the drive pinion. Remove the sleeve and pull the inboard bearing (25A) from the shaft. Remove the washer (28) from the shaft.

Inspect the pinion bushing (18) for excessive wear. If replacement is required, use a screwdriver or other tool to pry the bushing from the bearing housing.

Slide the pinion shaft (31) and gear (15) out of the pinion bearing (32). Remove the spacer washer (30).

Inspect the pinion shaft and gear for wear or broken teeth. If replacement is required, use an arbor (or hydraulic) press to remove the shaft from the gear.

Use an arbor (or hydraulic) press to remove the pinion bearing from the gear housing.

NOTE

It is not necessary to remove the drive shaft (35), drive gear (11), shaft bearings (4 and 4A) or eccentric cam (33) unless wear or damage is obvious. Inspect the parts, and if replacement is necessary, proceed as follows.

Remove the snap ring (37) from the drive shaft. Using a bearing puller, remove the eccentric cam and key (36) from the drive shaft. Remove the eccentric cam shim set (34) and washer (38). Tie and tag the shims or measure and record their thickness for ease of reassembly.

Slide the drive shaft and gear out of the gear housing. Slide the spacer washer (5) off the drive shaft.

Remove the snap ring (13). Use an arbor (or hydraulic) press to remove the gear (11) and key (12) from the shaft.

To remove the drive shaft bearings (4 and 4A), the spacer sleeve (2) must be coiled into a smaller diameter to allow passage through the I.D. of the bearings.

NOTE

After the spacer sleeve is compressed, it will be permanently damaged and require replacement.

To remove the spacer sleeve, remove the capscrew (3) and use a pointed tool to rotate the perforated steel sleeve until the seam is visible through the tapped hole. Apply pressure on one side of the seam until one edge overlaps the other. Reach through the I.D. of the bearings and continue to coil the spacer sleeve until it can be removed. Reinstall the capscrew (3).

Use an arbor (or hydraulic) press to remove the bearings (4 and 4A) from the gear housing..

It is not necessary to remove the locating pins (17) from the gear housing unless they are bent or damaged. If replacement is required, press the pins from the housing.

Gearbox Reassembly And Installation

(Figure 4)

Inspect the shafts (26, 31 and 35) for distortion, nicks or scratches. Dress small nicks and burrs with a fine file or emery cloth. Replace the shaft if defective.

NOTE

Do not heat the needle bearings (4, 4A and 32). These bearings are designed to be pressed into the

gear housing, not onto the shafts.

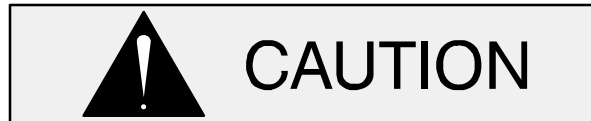

To prevent damage during removal from the shaft (26), it is recommended that the bearings (25 and 25A) be cleaned and inspected **in place**. It is **strongly** recommended that the bearings be replaced **any** time the shaft and bearings are removed.

The bearings may be heated to ease installation. An induction heater, hot oil bath, electric oven, or hot plate may be used to heat the bearings. Bearings should **never** be heated with a direct flame or directly on a hot plate.

NOTE

*If a hot oil bath is used to heat the bearings, both the oil and the container must be **absolutely** clean. If the oil has been previously used, it must be **thoroughly** filtered.*

Heat the bearings to a uniform temperature **no higher than 250° F (120° C)** and slide the bearings onto the shaft (26), one at a time, until they are fully seated. This should be done quickly, in one continuous motion, to prevent the bearings from cooling and sticking on the shaft.



Use caution when handling hot bearings to prevent burns.

After the bearings have been installed and allowed to cool, check to ensure that they have not moved out of position in shrinking. If movement has occurred, use a suitably sized sleeve and a press to reposition the bearings.

If heating the bearings is not practical, use a suitably sized sleeve and an arbor (or hydraulic) press to install the bearings on the shaft.



When installing the bearings onto the

shaft, **never** press or hit against the outer race, balls, or ball cage. Press **only** on the inner race.

If removed, install the snap ring (28) in the groove on the pinion drive shaft (26). Install the bearing (25A) on the pinion drive shaft against the snap ring. Install the sleeve (27). Install the bearing (25) onto the pinion drive shaft until squarely seated against the sleeve. Secure the bearing with the snap ring (24). Wrap the shaft and bearings in a clean cloth until reassembly in the bearing housing.

Install the bearing (4A) in the gear housing until it is flush with the outer machined face of the housing. Install a new spacer sleeve (2) through the open bearing bore, then press the bearing (4) into the bore until it is flush with the inner machined face on the housing.



When installing the bearings into the bearing bore, push against the outer race. **Never** hit the balls or ball cage.

Install the gear key (12) in the keyway in the drive shaft (35). Press the drive gear (11) onto the drive shaft and secure it with the snap ring (13). **Be sure** the drive gear seats against the snap ring.

Install the washer (5) onto the drive shaft and slide the assembled drive shaft and gear through the bearings in the gear housing. Install the same thickness of shims (34) as previously removed. Install the washer (38) and drive shaft key (36). Press the eccentric cam (33) onto the shaft and secure with the snap ring (37).

Press the pinion bearing (32) into the gear housing until the closed end is flush with the outer face of the bore.

Press the internal gear (15) onto the pinion shaft until it seats squarely against the pinion shoulder. Position the spacer washer (30) in the gear housing and slide the pinion shaft through the washer and into the pinion bearing.

Press the pinion bushing (18) into the bearing housing until fully seated.

Slide the assembled pinion drive shaft and bearings (25, 25A and 26) into the bearing housing (16) until the bearing (25A) is fully seated against the bore shoulder.

Press the oil seal (23) into the adaptor (22) with the lip positioned as shown in Figure 4. The outer face of the oil seal should be just flush with the face of the adaptor.

Install the washer (19) in the bearing housing. Press the oil seal assembly (21) into the bearing housing until fully seated. **Be careful** not to roll or damage the oil seal lip on the pinion keyway.

Install the housing gasket (6) and secure the cover plate (7) to the bearing housing with two of the capscrews and lockwashers (8 and 9).

If the locating pins (17) were removed, press new pins into the gear housing (1). Install the gasket (14) and position the bearing housing (16) over the internal gear (15) and against the cover plate so that the locating pins align with the holes in the cover plate. Be sure the teeth on the drive pinion (26) mesh with those on the internal gear (15). Tap against the bearing housing with a soft-faced mallet or wood block until the pinion bushing (18) fully engages the pinion shaft (31).

Secure the cover plate and bearing housing to the gear housing with the remaining attaching hardware (8, 9 and 10).

NOTE

The two longer capscrews (10) must be installed in the two lower holes in the gear housing.

Install the drive key (20) in the drive pinion.

(Figure 1)

Install the coupling half (12) on the drive pinion (26, Figure 4).

Secure the gearbox assembly (8) to the diaphragm ring (36) with the hardware (25 and 26). Connect the coupling halves and check alignment as described in Section B.

Secure the coupling guard (9) to the base with hardware (22 and 23).

Lubricate the gearbox as described in **LUBRICATION**.

Plunger Rod Reassembly And Installation

(Figure 3)

If the eccentric bearing (2) was removed, clean the bore of the eccentric cap (1) with a cloth soaked in cleaning solvent.



Most cleaning solvents are toxic and flammable. Use them only in a well-ventilated area free from excessive heat, sparks, and flame. Read and follow all precautions printed on solvent containers.

Use a suitably sized dowel and an arbor (or hydraulic) press to install a new eccentric bearing (2) into the eccentric cap until fully seated.

Slide the plunger rod (9) through the upper diaphragm plate (8). Install the flat washer (7), spring (6), spring washer (5) and jam nut (4). Compress the spring to the dimension shown in Figure 3 by tightening the jam nut.

Install the T-type lockwasher (3). Apply 'Loctite No. 242 Threadlocker' or equivalent compound on the plunger rod threads and screw the eccentric cap on until tight.

NOTE

The lubrication fitting (13) in the diaphragm plate must face the same direction as the lubrication fitting (13) in the eccentric cap.

Lubricate the eccentric bearing (2) with a thin coating of No.2 lithium base grease.

Diaphragm Installation

(Figure 3)

Position the diaphragm (10) on the upper diaphragm plate, making sure the lip is properly seated. Slide the studs (not shown) in the lower diaphragm plate (11) through the holes in the upper plate and secure with the nuts (12).

(Figure 1)

Install the plunger rod assembly (27) onto the eccentric cam (33, Figure 4) and secure with the snap ring (6).

Install the eccentric guard (1) and secure it with the hardware (2, 3, 4, 41, 42 and 43).

Lubricate the plunger rod assembly as described in **LUBRICATION**, Section E.

Secure the diaphragm pot assembly (35) to the diaphragm ring (36) with the hardware (32, 33 and 34).

Suction And Discharge Check Valve Installation

(Figure 2)

Inspect the check valve components and replace as required. Subassemble the check valve weights (27 and 30) and check valves (31) with the hardware (28 and 29).

If the inboard discharge flange (23) was removed, clean the mating surfaces and install the gasket (19). Secure the flange to the diaphragm pot with the hardware (21 and 22).

Subassemble the valve seat (25) and discharge check valve (26) to the discharge elbow (1) with the weights positioned as shown in Figure 2. Secure with the hardware (3 and 4).

Clean the mating surfaces of the valve seat and discharge flange (23). Install the gasket (24) and secure the outboard discharge flange, check valve, and seat to the inboard discharge flange with the hardware (5 and 6).

Check the operation of the check valve to ensure proper seating and free movement.

Clean the mating surfaces of the valve seat (5) and suction accumulator (10). Position the suction check valve, valve seat (15) and gasket (16) against the diaphragm pot (19) with the weights positioned as shown in Figure 2. Secure with the hardware (7 and 8).

Check the operation of the check valve to ensure proper seating and free movement.

Secure the suction accumulator (10) to the diaphragm pot with the hardware (13 and 14).

Connect the suction and discharge piping as described in **INSTALLATION**, Section B.

Refer to **OPERATION**, Section C before starting the pump.

LUBRICATION

Plunger Rod Assembly

(Figure 3)



The eccentric bearing should be lubricated thoroughly after each 8 hours of operation. Failure to do so may cause the bearing to overheat and fail.

Before attempting to lubricate the plunger rod assembly, rotate the eccentric cam until the grease fittings (15 and 16) can be accessed through the holes in the eccentric guard (1, Figure 1).

Use a grease gun to apply No. 2 lithium base grease to the upper lubrication fitting until grease

escapes from the eccentric cap. Lubricate the lower fitting until grease escapes from the top of the upper diaphragm plate inside the spring.

Gearbox

(Figure 4)

The gearbox was fully lubricated when shipped from the factory. Change the oil in a new gearbox at operating temperature after 100 hours of operation or four weeks, whichever comes first. To drain the oil, remove the oil cup (29) and position the pump and gearbox on its side. After draining, reinstall the oil cup and flush the case thoroughly with a light oil. Remove the oil cup and drain the flushing oil. Reinstall the oil cup.

To lubricate the gearbox, add SAE No. 30 non-detergent oil through the oil cup (29) until the oil level stabilizes at the middle of the oil cup. Check the oil regularly and maintain it at this level.

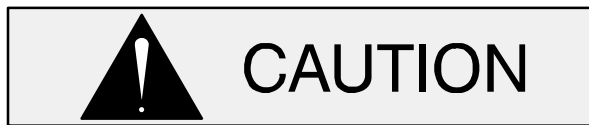

Monitor the condition of the bearing lubricant regularly for evidence of rust or moisture condensation. This is especially important in areas where variable hot and cold temperatures are common.

**For Warranty Information, Please Visit
www.grpumps.com/warranty
or call:
U.S.: 419-755-1280
Canada: 519-631-2870
International: +1-419-755-1352**

GORMAN-RUPP PUMPS