

HIGH-PRESSURE PORTABLE PUMP
PFP-9hpHND-EM-TWIN
GX270 HONDA WITH HIGH-PRESSURE PUMP

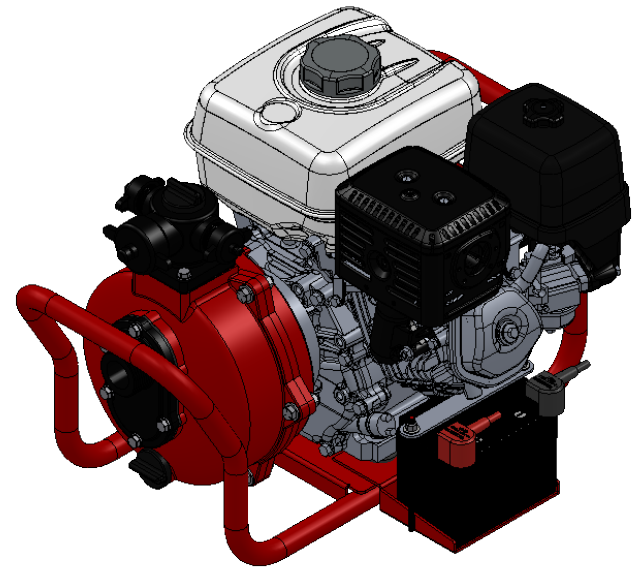

WE CAN CUSTOMIZE AS YOU WANT

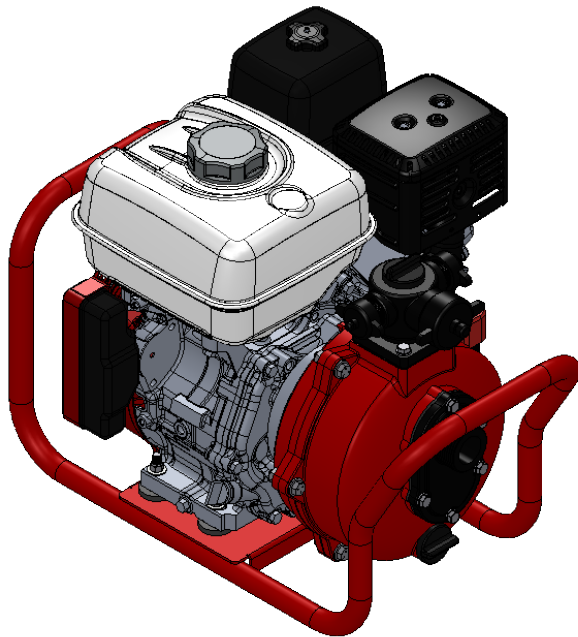
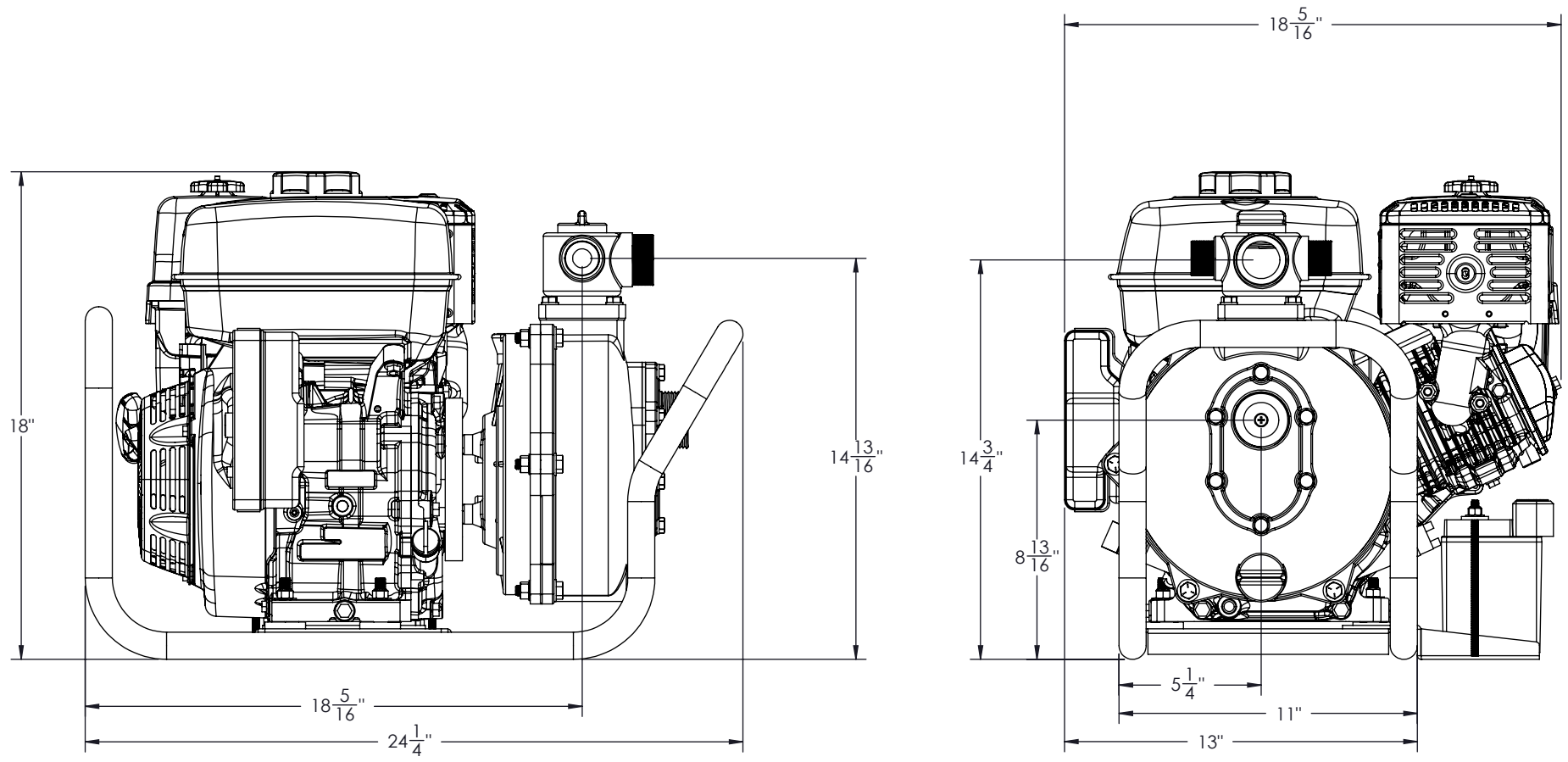

WET WEIGHT: 122 lbs

		CREATED BY: M.P. DATE: 10-08-16	TITLE : PFP-9hpHND-EM-TWIN HALF FRAME	WARNING THIS DOCUMENT REMAINS THE PROPERTY OF C.E.T. FIRE PUMPS MFG. ALL REPRODUCTION WITHOUT WRITTEN AGREEMENT FROM C.E.T. FIRE PUMPS MFG IS TOTALLY PROHIBITED.
		VERIFIED BY: M.P. DATE: 10-08-16	No: PO-09TW-0703-A	

REV.	DESCRIPTION	DATE	BY

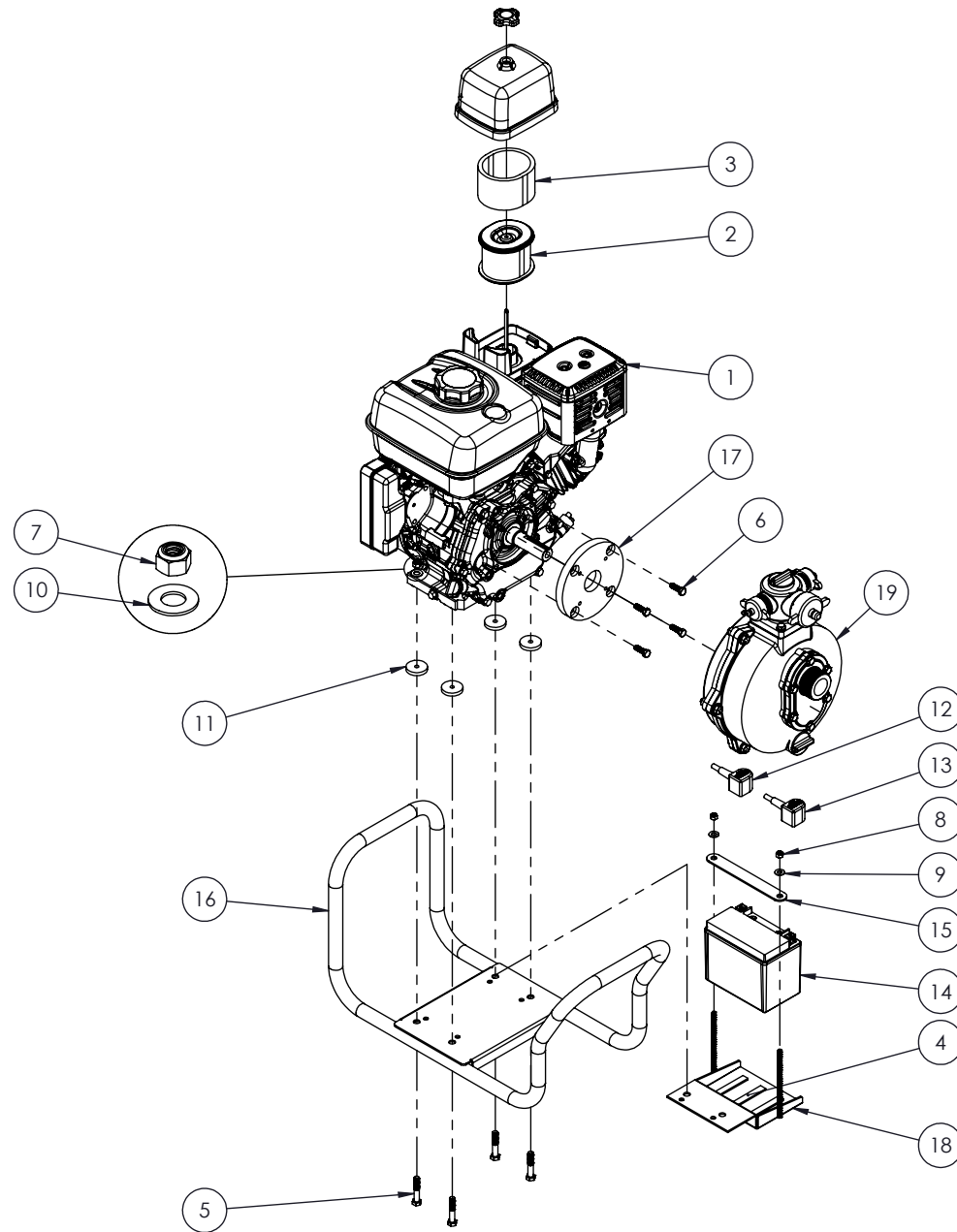

NO	PART NUMBER	DESCRIPTION	QTY
1	001-PP1-004	HONDA ENGINE (GX270), ELECTRIC/MANUAL 9hp GAS	1
2	003-PP1-104	AIR FILTER	1
3	003-PP1-111	AIR FILTER FOAM	1
4	020-PP1-008	BATTERY FOAM TAPE 1/2" x 3"	3
5	022-PP1-009	HEX. BOLT 3/8"-1.6 x 2" (Gr.5 ZINC)	4
6	022-PP1-451	HEX. BOLT 5/16"-24 x 1" (SS)	4
7	023-PP1-005	HEX. NYLON LOCK NUT 5/16"-18	4
8	023-PP1-006	HEX. NYLON LOCKNUT 1/4"-20	2
9	024-PP1-004	FLAT WASHER 5/16" ID x 3/4" OD	2
10	024-PP1-009	FLAT WASHER 3/8" int. x 7/8" ext.	4
11	025-PP1-015	RUBBER WASHER 0.312" INT x 1.5" EXT. x 1/4" TK	4
12	040-PP1-014	BATTERY CABLE CET-N-8.25	1
13	040-PP1-015B	BATTERY CABLE CET-R-10	1
14	040-PP1-075	BATTERY 12v	1
15	057-PP1-267A	BATTERY RETAINER PLATE	1
16	PO-0000-1724	HALF FRAME	1
17	PO-0000-3603	ADAPTER	1
18	PO-0000-9401	BATTERY SUPPORT	1
19	PO-00TW-2102	GOLIATH PUMP	1



ISO 9001
 Registered
 Quality
 Management

CREATED
 BY: M.P.
 DATE: 10-08-16
VERIFIED
 BY: M.P.
 DATE: 10-08-16

TITLE : PFP-9hpHND-EM-TWIN
 HALF FRAME
No: PO-09TW-0703-A

WARNING

THIS DOCUMENT REMAINS THE PROPERTY
 OF C.E.T. FIRE PUMPS MFG.
 ALL REPRODUCTION WITHOUT WRITTEN
 AGREEMENT FROM C.E.T. FIRE PUMPS MFG
 IS TOTALLY PROHIBITED.

REV.	DESCRIPTION	DATE	BY

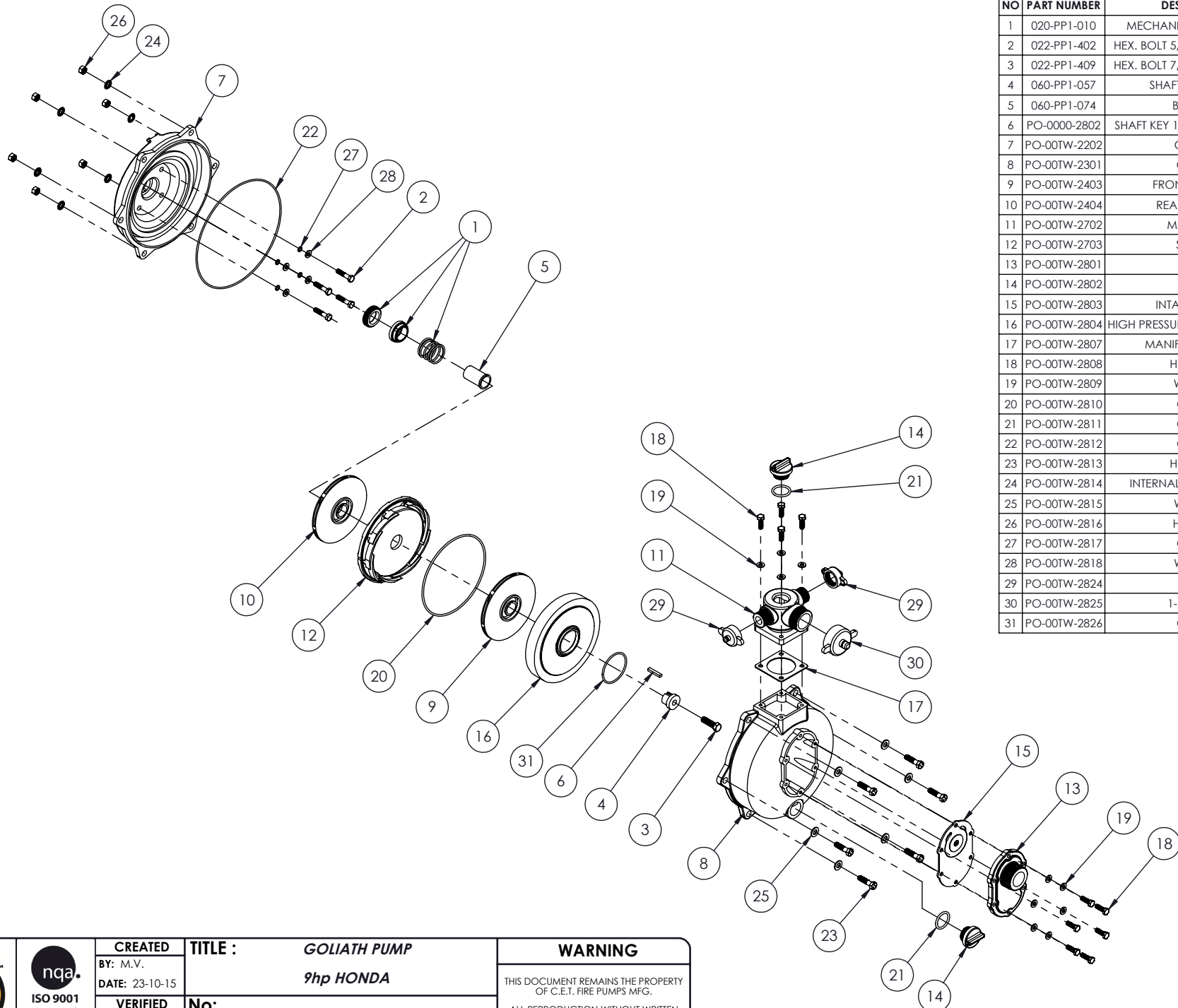

NO	PART NUMBER	DESCRIPTION	QTY
1	020-PP1-010	MECHANICAL SEAL 1" (SS)	1
2	022-PP1-402	HEX. BOLT 5/16"-18 x 1-1/2" (SS)	4
3	022-PP1-409	HEX. BOLT 7/16"-20 x 1-1/2" (SS)	1
4	060-PP1-057	SHAFT EXTENSION	1
5	060-PP1-074	BUSHING	1
6	PO-0000-2802	SHAFT KEY 1/4" x 3/16" x 1-3/8"	1
7	PO-00TW-2202	CASING	1
8	PO-00TW-2301	COVER	1
9	PO-00TW-2403	FRONT IMPELLER	1
10	PO-00TW-2404	REAR IMPELLER	1
11	PO-00TW-2702	MANIFOLD	1
12	PO-00TW-2703	STATOR	1
13	PO-00TW-2801	INTAKE	1
14	PO-00TW-2802	PLUG	2
15	PO-00TW-2803	INTAKE GASKET	1
16	PO-00TW-2804	HIGH PRESSURE IMPELLER COVER	1
17	PO-00TW-2807	MANIFOLD GASKET	1
18	PO-00TW-2808	HEX. BOLT	10
19	PO-00TW-2809	WASHER	10
20	PO-00TW-2810	O'RING	1
21	PO-00TW-2811	O'RING	2
22	PO-00TW-2812	O'RING	1
23	PO-00TW-2813	HEX. BOLT	6
24	PO-00TW-2814	INTERNAL LOCK WASHER	6
25	PO-00TW-2815	WASHER	6
26	PO-00TW-2816	HEX. NUT	6
27	PO-00TW-2817	O'RING	4
28	PO-00TW-2818	WASHER	4
29	PO-00TW-2824	1" CAP	2
30	PO-00TW-2825	1-1/2" CAP	1
31	PO-00TW-2826	O'RING	1



nqa.
ISO 9001
Registered
Quality
Management

CREATED
BY: M.V.
DATE: 23-10-15
VERIFIED
BY: M.P.
DATE: 06-11-15

TITLE : **GOLIATH PUMP**
9hp HONDA
No: **PO-09TW-0703-A**

WARNING

THIS DOCUMENT REMAINS THE PROPERTY OF C.E.T. FIRE PUMPS MFG.
ALL REPRODUCTION WITHOUT WRITTEN AGREEMENT FROM C.E.T. FIRE PUMPS MFG IS TOTALLY PROHIBITED.

REV.	DESCRIPTION	DATE	BY