

Serial Number : _____

This pump was built by :
C.E.T. Fire Pumps Mfg.



ACCEPT ONLY THE BEST

Instruction Handbook

(Version 1.0)

Model : PFP-13hpHND-FL

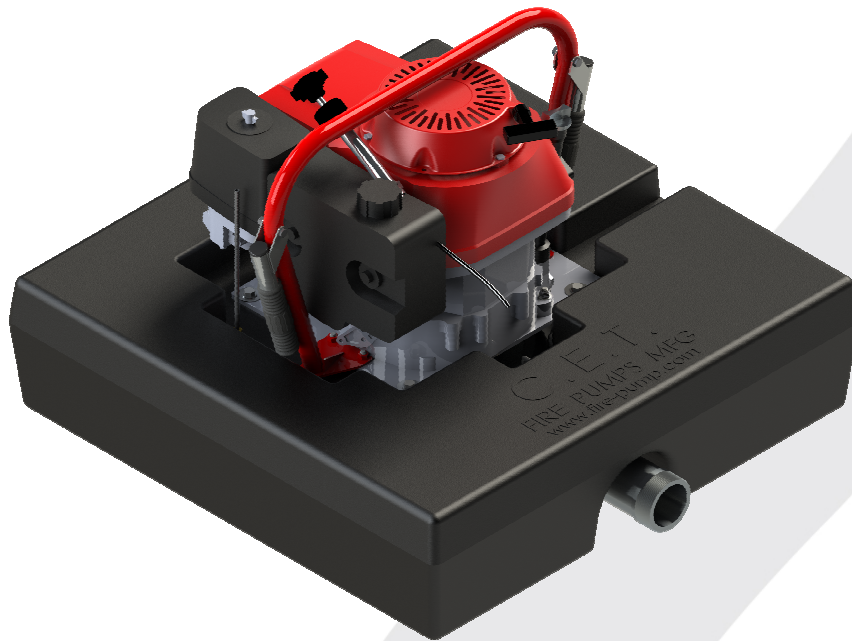

Your version of the pump, the engine and their accessories may vary from the one seen on the illustrations



2016, C.E.T. Fire Pumps Mfg. This handbook is subject to change without notice,
Contact your local C.E.T. dealer or C.E.T. direct to ensure you have the latest version.

Table of contents

1. FOREWORD	3 -
2. SAFETY INSTRUCTIONS	4 -
3. DESCRIPTION	7 -
4. GENERAL INSTRUCTIONS	10 -
5. TRANSPORT AND STORAGE	11 -
6. PERFORMANCE	12 -
7. STARTING PROCEDURE	13 -
8. OPERATING AND STOPPING	15 -
9. STARTUP	16 -
10. MAINTENANCE	17 -
11. TROUBLESHOOTING GUIDE	18 -
12. GENERAL WARRANTY	20 -
13. CONTACT US	21 -



1. Foreword

Congratulations on your purchase of a new C.E.T. fire pump, a quality product based on a century of experience in building fire-fighting equipment. If you follow the directives given in this handbook, your pump will be a useful ally for many years to come.



For your own safety and those around you, it is important that you read and understand each part of this handbook **BEFORE** you start the pump. Always keep this manual accessible so you can refer to it whenever the need arrives.

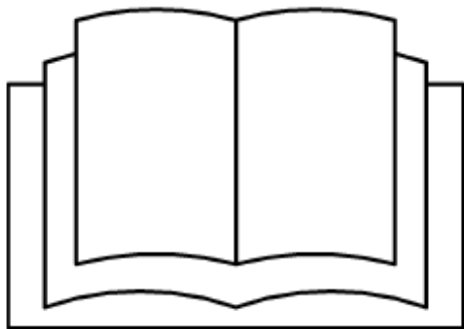

All rights reserved. No part of this manual may be reproduced without the prior written permission of **C.E.T. Fire Pumps MFG.**



2. Safety instructions

It is very important that you read and understand this handbook and the owner's manual of the engine before you start the pump.

DANGER



- **NEVER** run the engine in an enclosed area. Exhaust gases contain **carbon monoxide** which is an odorless and potentially deadly gas.
- **NEVER** run the pump in a radius of 3 ft (1m) of a building or combustible object.
- **NEVER** operate the engine if there is an accumulation of grass, leaves, or other combustible material around, behind or under the muffler.
- **NEVER** run the engine without a muffler or proper exhaust system.
- **NEVER** operate the engine if the fuel tank cap is removed, do not fill the tank while the engine is running. If fuel is spilled, move machine away from the area of the spill and avoid creating any source of ignition until it has completely evaporated.
- **NEVER** run the engine in an explosive environment.
- **NEVER** touch the spark plug or its components while running the engine; it could give you an electric shock.
- **NEVER** put your foot or hand near moving parts.
- **NEVER** wear loose, bulky or torn clothing while operating the pump, it could catch on moving parts and lead to serious injury.
- **NEVER** let your pump run unattended. It must always be operated by trained personnel assuring the stability and direction of discharge hose.
- **NEVER** operate this machine while under the influence of drugs or alcohol.
- **NEVER** spray the pressurised flow of water at a person or animal.



**WARNING**

- Not following the instruction handbook directives and operating procedure can lead to serious injuries, or even death. The operator and all other members or personnel handling the hoses connected to the pump must be trained and familiar with this type of product, know its limitations and have read and understood the Instruction Handbook and engine manual.
- **Risk of injuries resulting from pressure hazard.**

Before you disconnect a hose or take off a cap on the inlet or outlet, make sure the engine is stopped and open the drain valve to relieve pressure.

NEVER touch a pressurized flow of water, it is abrasive and could lead to serious injury.
- **Risk of injuries resulting from very hot water, scald and burn hazards.**

NEVER let the pump run for more than one minute with discharge valve(s) completely closed. When the pump is running make sure to always leave the discharge valve slightly opened, to avoid overheating of the pump. If the pump runs completely closed with water flowing for a few minutes, the water inside may heat-up and scald or burn the operator when he opens the valve. The mechanical seal and other components could also be damaged.
- **Risk of injuries resulting from high temperature components, burn hazard.**

NEVER touch the exhaust system, the muffler or the engine while it is running. All these components get very hot and touching them may cause burns.
- **Risk of injuries resulting from kickback from the recoil starter.**

To prevent injuries from kickback from the recoil starter, pull slowly on the rope until you feel a resistance, then pull quickly.
- **Risk of injuries resulting from tipping hazard.**

NEVER operate the engine if the pump is not stable. Always chose a flat, stable surface to operate the pump. The maximal slope for operation is 15°.



CAUTION	<ul style="list-style-type: none"> ○ NEVER run the pump for more than one minute without water. ○ NEVER run the engine without the proper amount of oil in the engine. ○ NEVER alter the engine and/or the pump even partially.
----------------	---

Signs and Symbols



This warning symbol means that not following the attached note will put at risk the security of the personnel operating near the pump. The words “danger”, “warning” and “caution” are used for levels of risk.

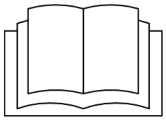

This symbol means that it is mandatory to read and understand this handbook as well as the operation manual from the engine manufacturer, **BEFORE** you start the engine.



This symbol represents the risk of injury from high temperature surfaces.



This symbol represents the risk of intoxication from dangerous gases, such as carbon monoxide.



This symbol represents the risk of injury caused by moving parts.



This symbol represents the hazards of handling dangerous material such as gasoline or diesel.



3. Description

This floating pump is directly driven by the very high quality GXV390 Honda engine. It is equipped with a recoil starter. This gasoline engine has an integrated fuel tank of 0.6 gallons (2.1L). The pump has a 2.5" (65mm) discharge and a 3" (77mm) inlet.

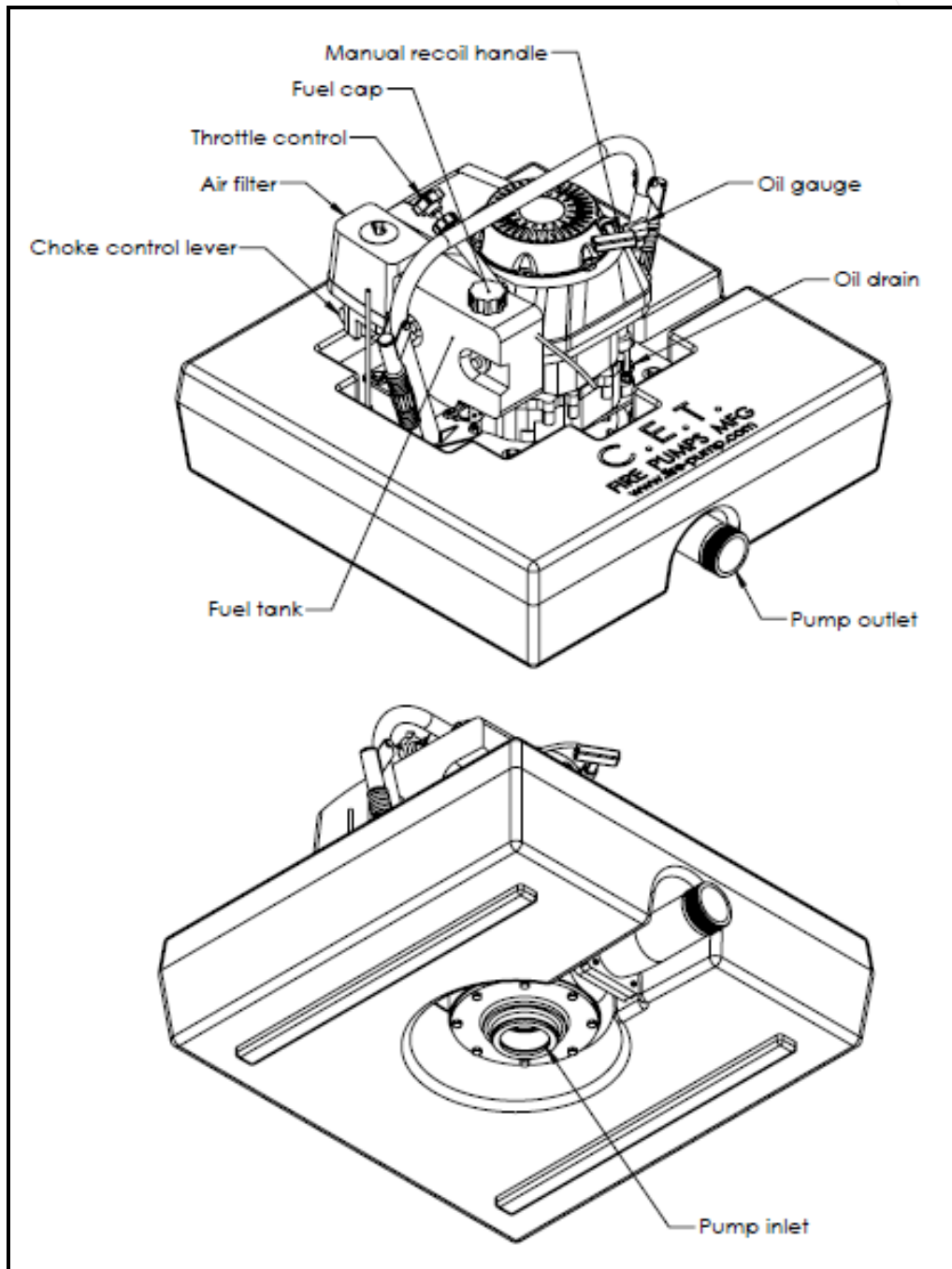

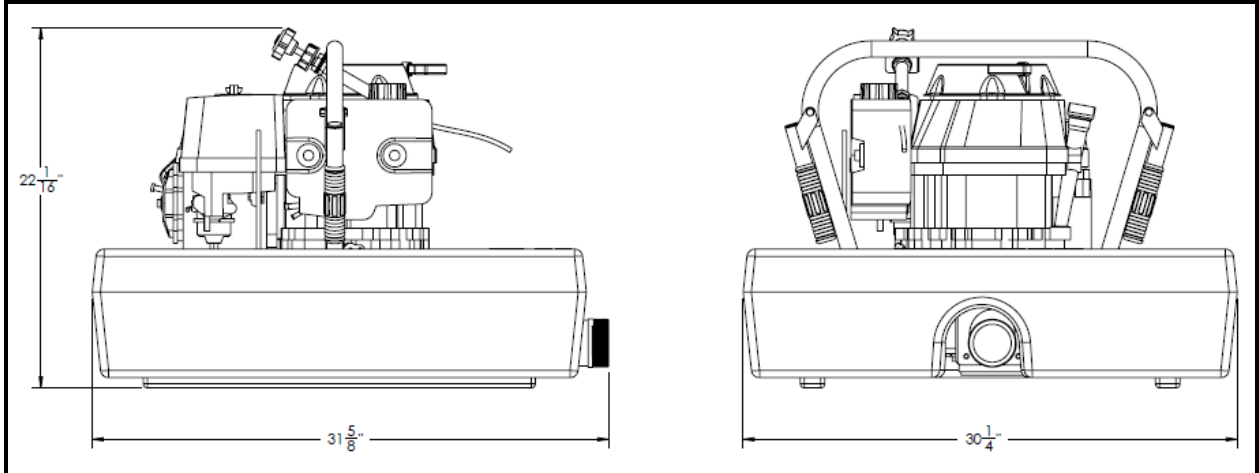
Dimensions:**Weight:** 120lbs (54kg)

The pump has a bronze impeller and a high resistance aluminum alloy body. It also has an axial mechanical seal. The pump can operate to a maximum pressure of 70 PSI (4.8bar). It has been designed to work at a temperature between 5°F (-15°C) and 104°F (40°C). The manufacturer does not guarantee the performances outside of this temperature range. The pump is operated with the throttle control knob on the side of the top of the frame. The pump should not run on a slope of more than 15° of incline or be tilted at more than 35° when stopped.



The assembly includes

- High quality GXV390 Honda gasoline engine.
- Centrifugal pump with one (1) outlet.
- Handling frame.
- Throttle control system.

The pump requires

- Oil (See the engine operator manual)
- Fuel (See the engine operator manual)
- Install in a properly ventilated area.

Recommended individual protective equipments (not included)

- Firefighting grade protective gloves (conforms to EN659 or equivalent).
- Protective glasses.
- Hearing protection

Intended use for application

This pump has been designed to move water for fire-fighting purposes. It has been engineered to run under the constant supervision of an operator properly trained. The pump was assembled according to the intended use of the engine manufacturer. Any use that doesn't conform with the previously stated intended use is not authorized unless C.E.T. Fire Pumps Mfg. gives such authorization in writing. A violation of this agreement could compromise the safety of the personnel working near the pump. The manufacturer's responsibility would be voided by C.E. Thibault Ladders Inc. and/or C.E.T. Fire Pumps Mfg. for damages resulting from unauthorized use.



4. General instructions

This pump must only be operated by trained personnel.



WARNING: The hydraulic power of the pump discharge can cause severe damage, even death. Never, under any circumstance, point the discharge hose toward a person or an animal, handle with care.

Highly contaminated water containing sand or rocks of diameters larger than 0.200" (5mm) could damage and shorten the lifespan of your pump. **Always use a strainer at the end of the suction hose.** If you are not sure of the quality of the pumped water, use a floating strainer to prevent drawing the sand or stone from bottom source.

The GXV390 engine runs on unleaded gasoline (with an octane rating of 86 or higher) and requires a quantity of 1.58qt (1.5L) of oil (SAE10W-30) for a running temperature range of -13°F (-25°C) to 95°F (35°C). (Refer to the engine manual)



WARNING: Always stop the engine before refilling the fuel tank.



WARNING: The exhaust system will get very hot. If the engine manufacturer recommendations are not followed it could also emit sparks, which could set the nearby environment on fire

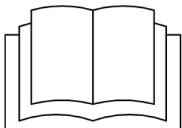

CAUTION: Read and understand the engine owner's manual and this instruction handbook before you start the engine.



5. Transport and storage

Transport :



WARNING: Never transport the pump while it is running.

The pump and its frame have been designed to be easily transported by two adults or more.

The pump shouldn't be inclined by more than 35° during transport, especially if the engine has oil in it.

Storage:



Warning: It is important to take into account the dangerous materials and components, such as gasoline and oil. Store away from heat source, flames and sparks (e.g. heater using a pilot).

The pump should be stored in a cool, dry place away from salty air. If the pump is to be stored for over 30 days, you should completely drain the fuel and carefully follow the steps written in your engine owner's manual.



6. Performance

The pump running under *normal conditions will give you these performances:

**Normal conditions : geostatic height of 4' 10" (1.5m), temperature de 59°F (15°C), water clear of sand and debris, atmospheric pressure < 3280' (1000m) from sea level*

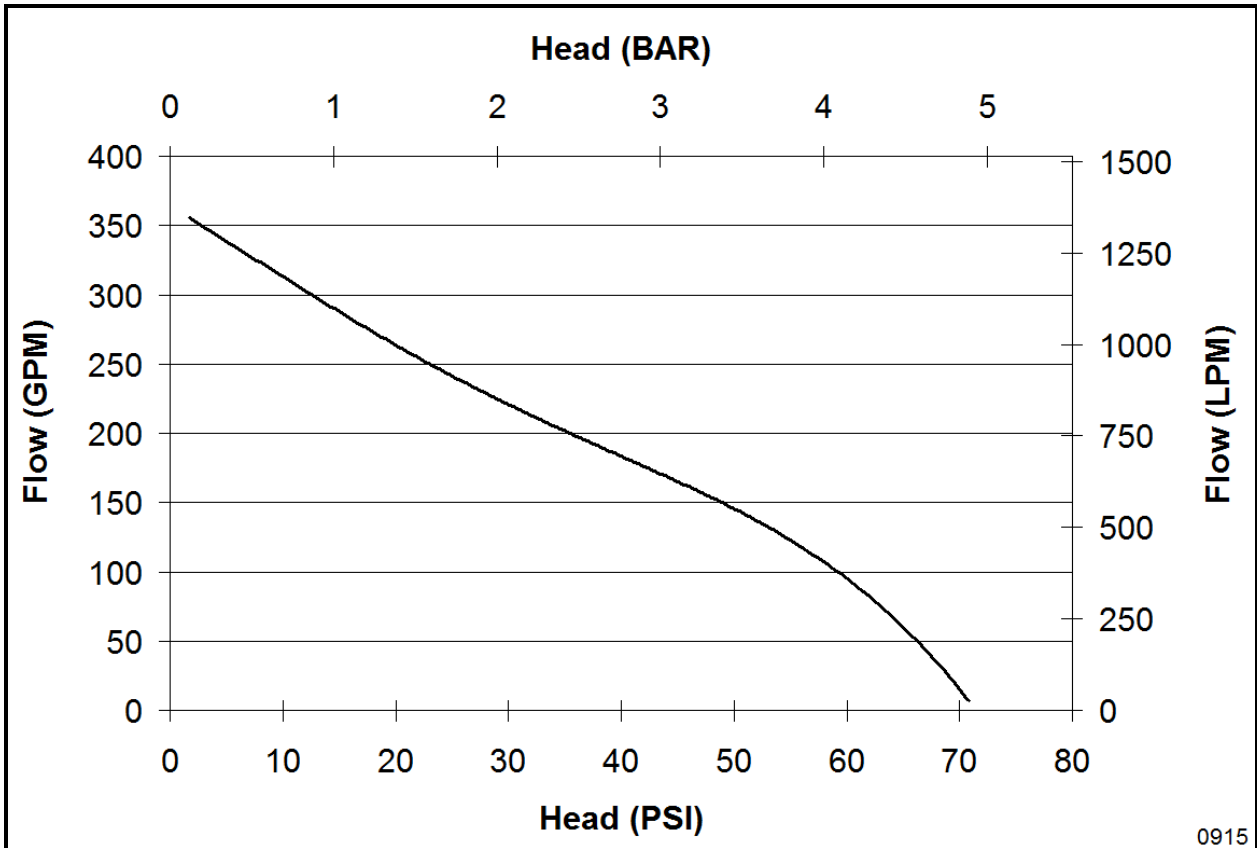

None conformance to the instructions given in this handbook can reduce the performances given by the pump.

Flow (GPM / LPM)	Pressure (PSI / Bar)
360 / 1362	0 / 0
250 / 946	25 / 1.7
125 / 473	50 / 3.5
0 / 0	70 / 4.8



7. Starting procedure

- 7.1. Place the pump on the water source.



WARNING: NEVER run the engine in an enclosed area. Exhaust gas contains carbon monoxide, an odorless and potentially deadly gas.

- 7.2. Check the oil level.

- 7.3. Check the fuel level.

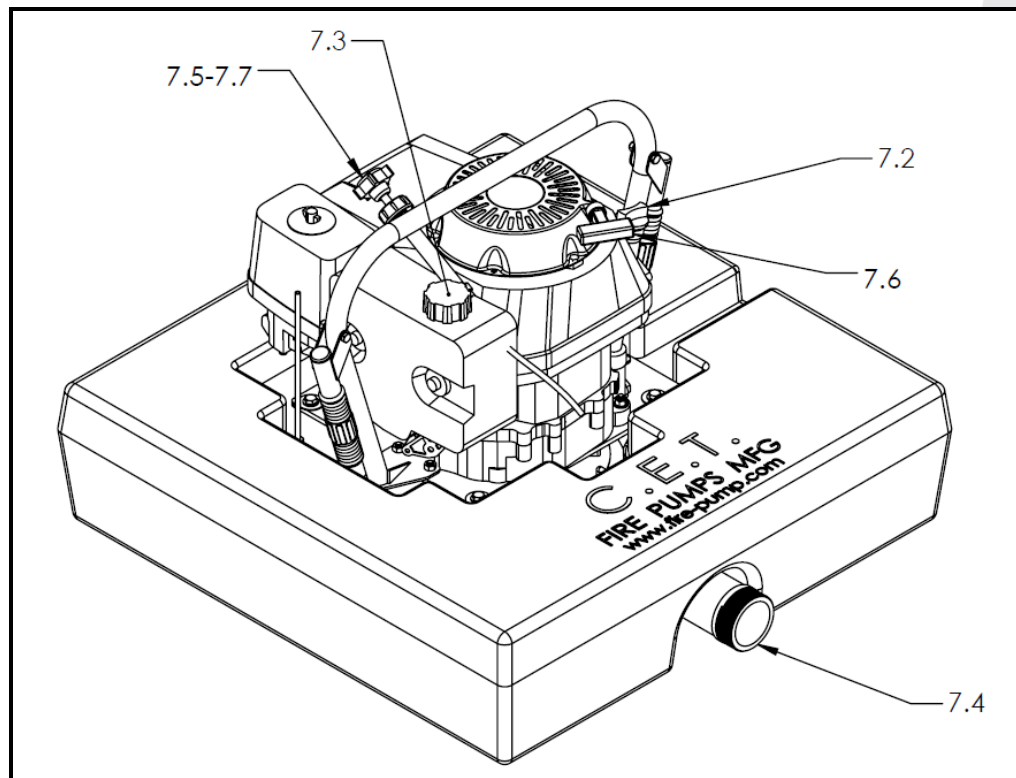

- 7.4. Connect the discharge hose. Make sure that there is a rubber seal on the adapter and screw it tight. Verify the water source to be used is clear of sand and/or small rocks, if you have any doubt about your water source, we recommend you use a strainer. If sand enters your pump it would damage the seal and wear rings, reducing useful life. The water source should be at least 12" deep.





WARNING: The discharge hose will tend to straighten up when filled with water. Make sure it won't compromise the safety of your installation. Warn the surrounding people before you start the pump. It is important that you evaluate the trajectory of the hose to prevent incidents.

7.5. Put the control throttle in starting position.



WARNING: Always make sure a trained person firmly holds the extremity of the discharge hose before starting the engine. The hydraulic power of the pump could cause the hose and nozzle to move violently and cause material damage, severe injuries or even death.

7.6. *Start the engine by pulling on the recoil starter handle. *Check the engine owner's manual for the starting and stopping procedure. **NOTE:** For start-up, or when starting the engine after a long period of storage, let it run at idle RPM'S for 30 minutes.



WARNING: Make sure you know the stopping procedure of the engine before starting it.

CAUTION: NEVER run the pump dry for more than one (1) minute, it could damage the mechanical seal.

7.7. You can adjust the ratio flow/pressure by two means.

7.7.1. Adjust the throttle of the engine to desired pressure.

7.7.2. Control the opening of a valve or a nozzle at the end of the discharge hose. By reducing the opening, pressure will increase and flow will decrease.



8. Operating and stopping

Adjust the throttle lever or the opening of the nozzle at the end of the discharge hose accordingly to the desired flow/pressure rate.

To stop the engine, put the throttle control to the stop position and hold it there for a few seconds.

CAUTION: NEVER leave water inside the casing of the pump and valves. The water could freeze and damage them.

CAUTION: After each use, it is important to flush the inside of your pump with fresh water. This will help prevent damages and wear to the pump components.

IF the pump has been used to pump salt water:

- Drain the salt water completely.
- Flush the pump with fresh water to prevent corrosion and salt crystals from forming.
- Apply a spray silicone compound to the pump internal components.
- Replace hose connection caps. (If your pump is equipped with them).

Initial warm up period:

The first time, run the pump at idle RPM's for 30 minutes.



WARNING: NEVER let the pump run unsupervised. Stop the engine before transporting the pump or filling the fuel tank. The engine and its components will be very hot when and after running. Let it cool down before touching it.



9. Startup

Get the pump ready for start-up:

Remove from packing. Check the oil level of the engine and the level of fuel. Make sure the electrical connections have not been damaged or disconnected during transport. Make sure that no bolt or screw has been loosened by vibration in transport. Every pump that we build is tested at the factory and meets rigorous standards of quality. To make sure that nothing outside our control occurred between our test and the delivery of your pump, we recommend you do a functional test

Functional test:

Make sure to completely submerge the pump. Connect a discharge hose of 2.5'' diameter and not more than 30'. The pump test should be done at an altitude lower than 3280' (1000m) from sea level.

Not matching these conditions could reduce the performance of the pump.

Initiate starting procedure:

Confirm the pump performances correspond to the chart given in this manual (see section 6. Performance), with a maximum variation of 15%. If your test doesn't match these results, make sure you have the same conditions as described here and that you have correctly followed the starting procedure. Otherwise contact your local C.E.T. Fire pumps dealer or C.E.T. direct.



10. Maintenance

This periodic maintenance table is not enough for a complete servicing of the engine. You must refer to the owner’s manual to make sure to apply a complete maintenance of the engine. It is highly recommended that you keep a record of the number of running hours of your pump and all the maintenance operations applied on it. If you require spare parts or a more detailed maintenance procedures, please contact your local C.E.T. Fire pumps dealer or C.E.T. direct.

Maintenance	Interval			
	Daily	First 8 hours	Every 50 hours	Every 100 hours
Check oil level and add some if required	■			
Check for oil or fuel leakage	■			
Make sure the throttle control is working well.	■	■		
Check and clean the air intake, also make sure the recoil starter rope is undamaged.		■	■	
Check the protective frame for damage.	■			
Clean the pump inlet strainer and make sure it is not obstructed.	■			
Check the seals for any leakage, change them if required.	■		■	
Make sure the electric components are properly connected and safe	■			■

Change the engine oil annually, even if the number of running hours is less than recommended.

Dispose properly of the used oil and filters according to the local environmental regulations.



11. Troubleshooting guide

For all problems that are not covered by this table, please contact your local C.E.T. Fire pumps dealer or C.E.T. direct.

Problem	Probable cause		Remedy	
The engine won't start	No fuel in the combustion chamber	The fuel tank is empty	Fill the fuel tank	
	The electric starter doesn't work	Not enough electrical power	Check the electrical connections, check if the battery is charged, if required charge the battery. Check the engine manual for faulty electrical starter problems. Use the recoil starter.	
	Faulty engine	Refer to the troubleshooting guide of the engine owner's manual		
The engine output is low	Engine is overheating	Refer to the troubleshooting guide of the engine owner's manual		
	The engine won't speed up	The throttle control system is malfunctioning	Reset, repair or change the throttle control system.	
The engine seems to speed up and down	Air pockets are created in the suction hose	Air pockets in the suction hose	Make sure the inlet hose is straight and doesn't have a sharp turn angle allowing the formation of an air pocket.	
		Suction hose is not air tight	Make sure to have well understood and applied the priming protocol of the pump. Check for any possible air leakage in the suction hose. Check the mechanical seal for leakage.	
	Faulty engine	Refer to the troubleshooting guide of the engine owner's manual		
The engine works but the priming system doesn't seem to be able to fill the pump. (part 1/2)	The exhaust gas flow going through the venturi isn't high enough	The engine speed is too low	The throttle should be in the "fast" position while priming. For engine's speed problem, refer to "the engine output is low" section.	
		The exhaust port isn't completely closed.	Check if the exhaust port closing handle completely covers the outlet pipe. Clean up and flatten the closing surface beneath the exhaust port closing handle.	
	The pump is not air tight	The primer sucks in ambient air and thus can't take out all the air from the suction pipe	Make sure drain valve and discharge valve are closed. Verify the suction hose(s) and the gaskets are in good conditions.	
			Verify the end of the suction hose is completely submerged by at least 12" (305mm) of water. When pumping high volumes of water, sometimes a whirlpool is created by the suction. If so, make sure to submerge the suction hose end by at least 24" (610mm).	
The pump is too high above the water source	The height of water to pull up is above the priming system capacity	The priming system is guaranteed up to 20' (6meters). Above this height it is highly suggested to reduce the height difference.		



Problem	Probable cause		Remedy
The engine works but the priming system doesn't seem to be able to fill the pump. (part 2/2)	The pump is too far from the water source	The volume of air to vacuum is above the priming system capacity	Always put your pump as close to the water source as possible. Having a very long suction hose will take more time to prime and eventually overheat the mechanical seal. Never run the primer continuously for more than 2 minutes.
	A part of the suction hose is higher than the pump level	Air will get stuck in the higher level hose section.	If possible, try to avoid having higher sections suction hose than the pump level. Otherwise, close the discharge valve as soon as the pressure drops and prime the pump again. Repeat the procedure to eliminate all the air pockets in the hose, it is possible the procedure must be applied many times.
	The priming system is not maintained/engaged for long enough	Only partially vacuums the suction hose	Make sure to wait until some water comes out from the venturi before opening the discharge valve. The priming time for a height of 10' (3 meters) shouldn't take more than 45 seconds.
	Faulty priming system	An accumulation of carbon deposits or dust is obstructing the priming system.	Carefully dismantle the priming system, clean it up or replace the components if necessary.
The engine runs fine, but the pump output is low.	The restrictions or energy losses added to the system reduces significantly the pump performance.	The difference of elevation between the end of the discharge hose and the pump is too high.	Reduce the elevation difference, use a smaller nozzle at the end of the hose to build more pressure (while reducing the flow) or contact your local C.E.T. dealer for a more powerful model.
		Old or malfunctioning intake hose	It is possible on old suction hoses the inner liner rough up enough to cause friction loss and reduce capacity. In some rare cases, the inner liner completely detaches from the outer wall making priming almost impossible.
	Restriction on the suction side	Obstructed intake or strainer	Check the strainer if it clogged with leaves, algae, rocks, etc. Clean it up and make sure the end of the suction pipe doesn't touch the bottom of the water source. We recommend the use of a floating strainer.
	The pressure gauges indications are wrong.	Faulty or damaged pressure gauges or their tubing connections.	Check the connections of the pressure gauge and make sure they are watertight. Also check if there is no ice or debris blocking the tube. Check and test the pressure gauges, change them if necessary.
	The pump maximum flow has been reached.	Over the maximum flow limit the pump will begin to cavitate	Do not exceed the pump flow limit, cavitation will accelerate wear and damage the inner parts of the pump.



12. General Warranty

C.E.T. FIRE PUMPS MFG. warrants to the original purchaser that C.E.T. FIRE PUMPS MFG. will, at its election, either replace or repair any part of the new equipment sold to the purchaser hereunder which has been given no abnormal use; and which has received proper maintenance; and which is determined by C.E.T. FIRE PUMPS MFG. to be defective in material or workmanship; and which has, within three (3) years after delivery to the purchaser be returned at the purchaser's expense, with transportation charges prepaid, to C.E.T. FIRE PUMPS MFG. factory OR which has, within three (3) years after delivery to the purchaser, been pre-approved by C.E.T. FIRE PUMPS MFG. for a third-party to perform the work. All problems shall be reported to C.E.T. FIRE PUMPS MFG. in writing and damaged parts shall be returned to C.E.T. FIRE PUMPS MFG..

Exclusions from warranty

1. C.E.T. FIRE PUMPS MFG. incurs no liability under this warranty or otherwise for parts, accessories or components not manufactured by it, but purchased for assembly into the equipment, but C.E.T. FIRE PUMPS MFG. will assign to the Purchaser whatever warranty rights are extended by the supplier of such part, accessory or component
2. C.E.T. FIRE PUMPS MFG. incurs no liability under this warranty or otherwise, for equipment which has been abused, altered or improperly maintained, or for equipment which has been returned for inspection or repair more than ten (10) days after defect complained of has been or should have been discovered by the Purchaser, or Equipment which is operated after the defect has been discovered.
3. C.E.T. FIRE PUMPS MFG. incurs no liability for alteration or repairs unless the Purchaser first receives C.E.T. FIRE PUMPS MFG. / written consent or approval. C.E.T. FIRE PUMPS MFG. will not be responsible for work or repairs made or done by others.
4. C.E.T. FIRE PUMPS MFG. incurs no liability for design alterations, parts, accessories or components which are not standard but are specified by the Purchaser for incorporation into the equipment.

Interpretation

C.E.T. FIRE PUMPS MFG. shall not be liable for transportation charges either in shipment to or by it and shall not be liable for loss of use, or consequential damage of any kind in connection with the sales, alteration, repair or replacement of any equipment or part thereof. Liability under this warranty is limited to replacement or repair and in any event shall not exceed the purchase price paid. This warranty is not transferable by the Purchaser. C.E.T. FIRE PUMPS MFG. reserves the right to make changes in design or add any improvements to the Equipment at any time without incurring any obligation to install or modify same on other equipment previously supplied.

There are no other warranties, conditions or representations, expressed or implied, except the above.



13. Contact Us

For repair or questions about warranties, please contact your local C.E.T. fire pumps dealer or C.E.T. direct.

E-mail : service@fire-pump.com

Tel. : 1-450-568-2719

Fax : 1-450-568-2613

**C.E.T. fire pumps MFG
75, Hector Street, C.P.90
Pierreville, QC
J0G 1J0**



ACCEPT ONLY THE BEST

For more information on our products go to

www.fire-pump.com



2016, C.E.T. Fire Pumps Mfg. This handbook is subject to change without notice,
Contact your local C.E.T. dealer or C.E.T. direct to ensure you have the latest version.