



**Barmesa<sup>®</sup>**  
**Pumps**



seal plate and  
suction/discharge chamber  
in stainless steel

# High Efficiency Vertical Multistage Centrifugal Pumps **HMV series**

[barmesapumps.com/US](http://barmesapumps.com/US)

<b>Pump, motor and operating conditions</b> . . . . .	<b>1</b>
<b>Applications</b> . . . . .	<b>2</b>
<b>Performance scope &amp; specifications</b> . . . . .	<b>3</b>
<b>NPSH &amp; operation in parallel</b> . . . . .	<b>4</b>
<b>Max. pressure &amp; temperature</b> . . . . .	<b>5</b>
<b>Components &amp; materials</b> . . . . .	<b>6</b>
<b>Performance curves &amp; dimensions HMV5</b> . . . . .	<b>7</b>
<b>Performance curves &amp; dimensions HMV14</b> . . . . .	<b>8</b>
<b>Performance curves &amp; dimensions HMV22</b> . . . . .	<b>9</b>
<b>Performance curves &amp; dimensions HMV45</b> . . . . .	<b>10</b>
<b>Performance curves &amp; dimensions HMV70</b> . . . . .	<b>11</b>
<b>Performance curves &amp; dimensions HMV95</b> . . . . .	<b>12</b>
<b>Performance curves &amp; dimensions HMV140</b> . . . . .	<b>13</b>
<b>Performance curves &amp; dimensions HMV140-2</b> . . . . .	<b>14</b>
<b>Performance curves &amp; dimensions HMV200</b> . . . . .	<b>15</b>
<b>Performance curves &amp; dimensions HMV200-2</b> . . . . .	<b>16</b>
<b>Performance curves &amp; dimensions HMV300</b> . . . . .	<b>17</b>
<b>Performance curves &amp; dimensions HMV300-2</b> . . . . .	<b>18</b>
<b>Technical data</b> . . . . .	<b>19</b>

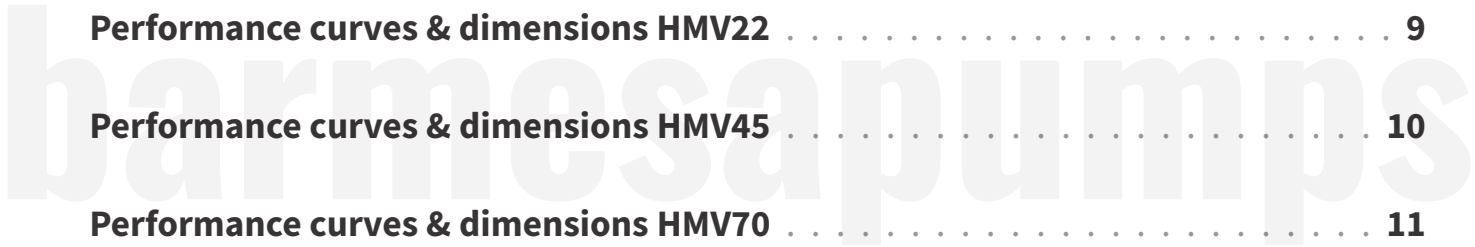

# VERTICAL MULTISTAGE PUMPS



Our vertical multistage centrifugal pumps are driven by premium efficiency electric motors. The output shaft of the motor is directly connected with the pump shaft through a coupling. The pressure resistant cylinder and flow passage components are fixed between the pump head and the inlet and outlet section with clamping bolts. The inlet and outlet are located at the bottom of the pump in the same plane.



## Premium efficiency motor

- ✓ 1 HP up to 75 HP
- ✓ Totally enclosed fan-cooled
- ✓ Three phase, 3500 RPM
- ✓ 230/460 volts, 60 Hz
- ✓ IP55 protection class
- ✓ Class F insulation



## Operating conditions

- ✓ Thin, clean, non-flammable and non-explosive liquid, free of granules and fibers.
- ✓ Liquid temperature:
  - Hot water type: 5 °F ~ 248 °F
- ✓ Ambient temperature up to 104 °F
- ✓ Height up to 1000 ft



## Applications

HMV series pumps are designed to ensure that they can be installed directly into the piping system with the same diameters and the outlet and inlet are at the same level. This structure design makes the connection of the pump to the pipeline more compact.

We have them in a wide variety of specifications to meet your flow and pressure requirements. In addition, they can handle not only water, but also various industrial liquid media, of different temperatures, flow rates and pressure ranges. A single pump can solve multiple water supply problems!

### Water supply

- ✓ Water filtration and transport
- ✓ Water distribution
- ✓ Net pressure increase for high-rise buildings
- ✓ Industrial water pressure boosting

### Irrigation

- ✓ Irrigation by region
- ✓ Sprinkler irrigation
- ✓ Drip irrigation

### Industrial boosting

- ✓ Process water system
- ✓ Cleaning system
- ✓ High pressure washing system
- ✓ Fire fighting system
- ✓ Automobile cleaning system

### Delivery

- ✓ Oil and alcohol
- ✓ Acid and alkali
- ✓ Ethylene, glycol and coolant

### Industrial liquid transportation

- ✓ Refrigeration and air conditioning system
- ✓ Boiler feed water system
- ✓ Temperature system
- ✓ Machine adjustment

### Water treatment

- ✓ Ultrafiltration system
- ✓ Reverse osmosis system
- ✓ Distillation system



# PERFORMANCE SCOPE & SPECIFICATIONS

PARAMETER	HMV5	HMV14	HMV22	HMV45	HMV70	HMV95
Rated flow (gpm)	5	14	22	45	70	95
Rated flow (lps)	0.3	0.9	1.4	2.8	4.4	6
Max. flow (gpm)	10	21	35	65	101	139
Max. flow (lps)	0.6	1.3	2.2	4.1	6.4	8.8
Max. pressure (PSI)	522	479	406	479	377	319
Motor capacity (HP)	1 - 4	1 - 5.5	1.5 - 7.5	3 - 20	3 - 25	3 - 25
Max. temp. (°F)	248					
Max. temp. (°C)	120					
ANSI flange	1¼"	1¼"	1¼"	1½"	2"	2"

PARAMETER	HMV140	HMV200	HMV300	HMV440	HMV620	HMV750
Rated flow (gpm)	140	200	300	440	620	750
Rated flow (lps)	8.8	12.6	19	28	39.2	47
Max. flow (gpm)	200	292	411	650	831	1030
Max. flow (lps)	12.6	18.4	25.9	41	52.4	65
Max. pressure (PSI)	479	464	334	421	435	377
Motor capacity (HP)	5.5 - 60	7.5 - 75	15 - 75	20 - 120	20 - 150	25 - 150
Max. temp. (°F)	248					
Max. temp. (°C)	120					
ANSI flange	2½"	3"	4"	4"	6"	6"

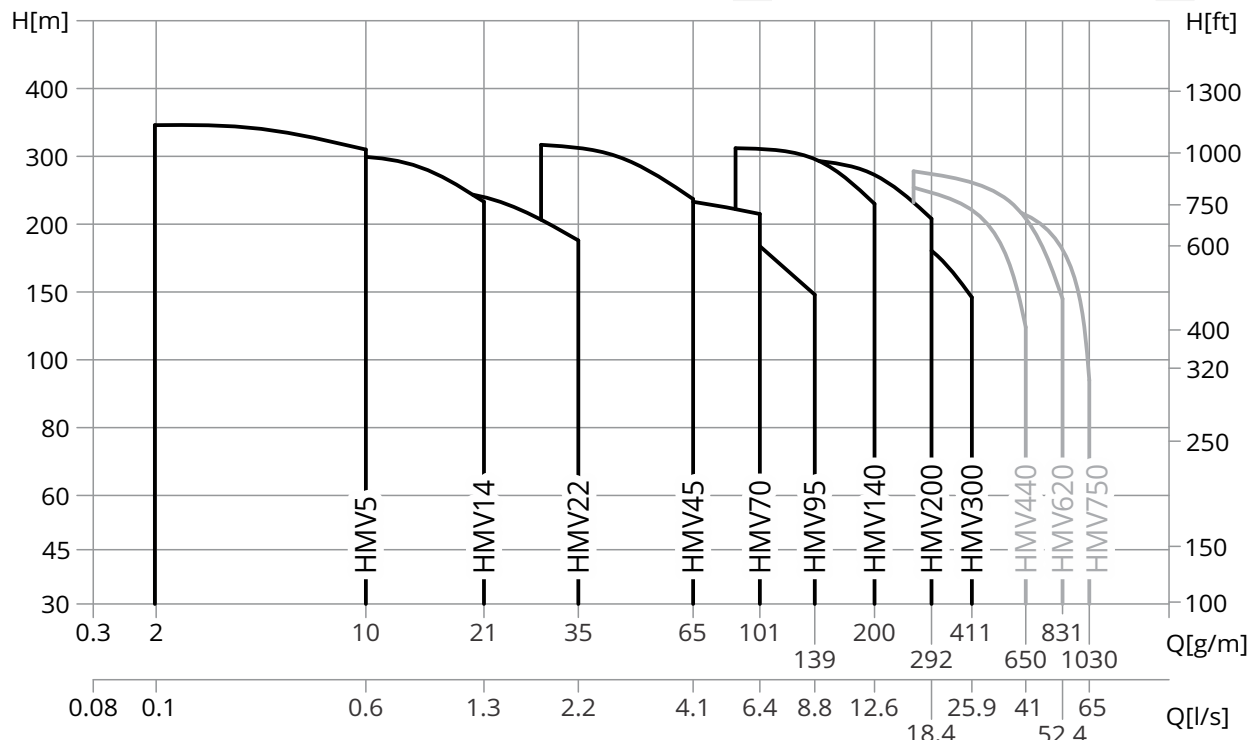

## Minimum inlet pressure NPSH

If the pressure in the pump is lower than the pressure of the vapor used to transport the liquid, cavitations will occur. To avoid cavitations, a minimum pressure must be guaranteed on the inlet side of the pump. The maximum suction pressure can be calculated with the following formula:

$$H = P_b \times 10.2 - NPSH - H_f - H_v - H_s$$

Where:

- **P<sub>b</sub>** = atmosphere pressure in bar (can be set as 1). In a closed system, it means system pressure.
- **NPSH** = net positive suction head in meters. It can be read out from the point of possible max. flow rate shown on NPSH curve.
- **H<sub>f</sub>** = pipeline loss at the inlet in meters.
- **H<sub>v</sub>** = steam pressure in meters.
- **H<sub>s</sub>** = safety margin of minimum 0.5 meters delivery head.

If the calculated result H is positive, the pump may run under the max. suction pressure H. In case the calculated result H is negative, a delivery head of min. inlet pressure is necessary.

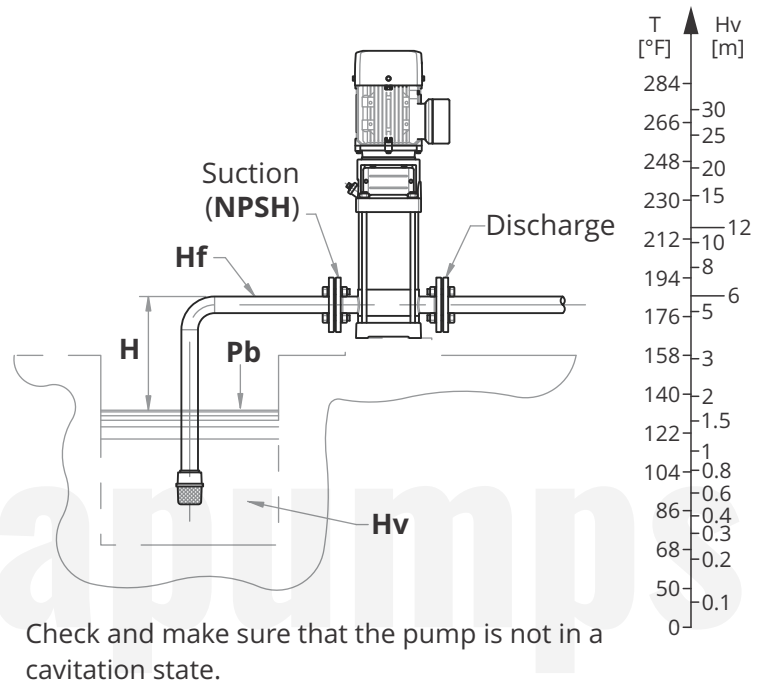

## Operation in parallel

The connection of several pumps in parallel operation will be much more beneficial than the operation of a single large pump.

- ✓ Applicable to the different modes of operation required in a variable flow system.
- ✓ This setup increases the possibility of water supply when a pump fails, because only a part of the system flow is affected.

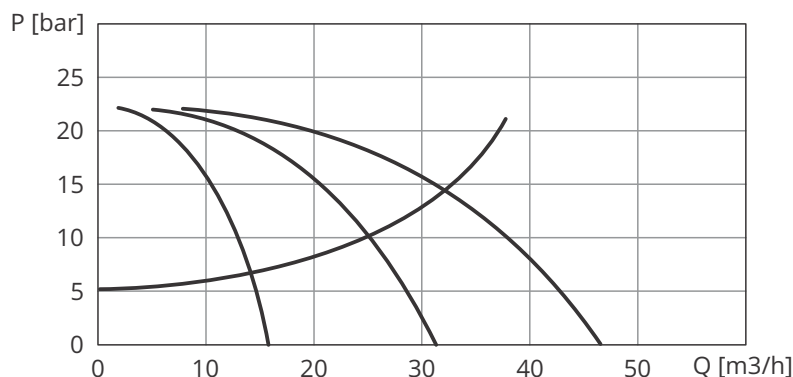

# MAX. PRESSURE & TEMPERATURE

## Maximum working pressure

The following graph shows the limitation of pressure and temperature, which shall be in the scope as shown.

MODEL	CURVE No.
HMV 5	7
HMV 22	2
HMV 14 y 45	8
HMV 70 y 95	3
HMV 140	
10-1 ~ 50-2	1
50 ~ 80-2	4
80 ~ 100	6
HMV 200	
10-1 ~ 40	1
40-2 ~ 60	4
70-2 ~ 80-2	6
HMV 300	
10-1 ~ 30	1
40-2 ~ 50-2	4
HMV 440	
10 ~ 30	1
40-2 ~ 50	4
50-3 ~ 60	5
HMV 620	
10-1 ~ 30	1
40-2 ~ 50	4
60-2 ~ 60	5
HMV 750	
10-1 ~ 30-1	1
30 ~ 50-2	4

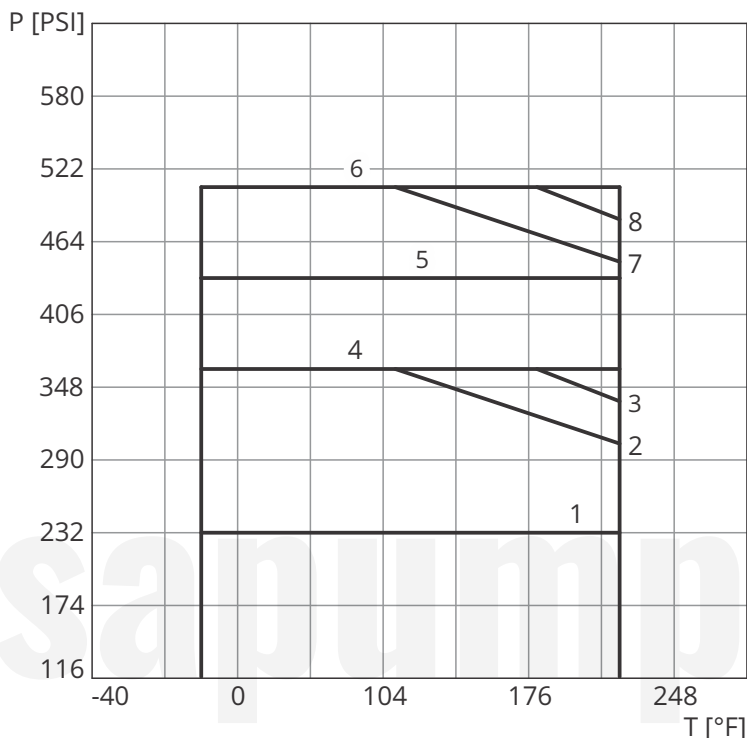

## Max. ambient temperature

When the pump operates at an ambient temperature above 104 °F or at an altitude above 3281 ft, due to low air density and poor cooling effects, the output power of the P2 motor will be reduced to some extent. If the pump operates under the above conditions, it should be equipped with a higher power motor.

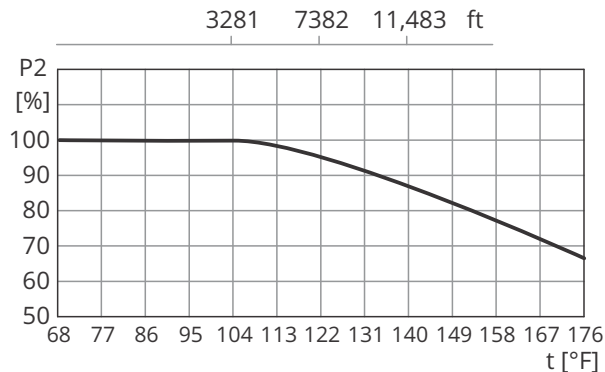

## Materials for HMV 5, 14, 22

ITEM	NAME	MATERIAL	AISI/ASTM
1	Motor	-	-
2	Bracket	Ductile cast iron	ASTM A536 65-45-12
3	Seal base	Stainless steel	AISI 304
4	Mechanical seal	TC/Graphite/Viton®	-
5	Top diffuser	Stainless steel	AISI 304
6	Diffuser	Stainless steel	AISI 304
7	Support diffuser	Stainless steel	AISI 304
8	Coupling	Ductile cast iron	ASTM A536 65-45-12
9	Impeller	Stainless steel	AISI 304
10	Cylinder	Stainless steel	AISI 304
11	Shaft	Stainless steel	AISI 304
12	Bearing	Tungsten carbide	-
13	Inducer	Stainless steel	AISI304
14	Inlet & outlet chamber	Stainless steel	AISI 304
15	Base	Cast iron	ASTM 25B

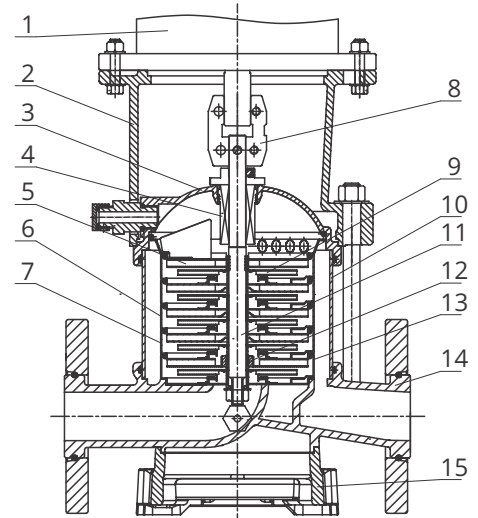

HMV 5, 14, 22

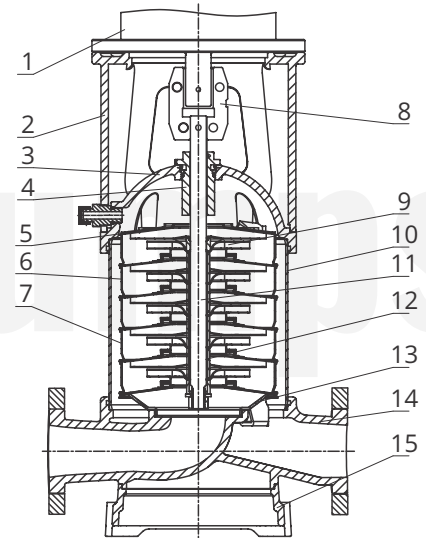

HMV 45, 70, 95

## Materials for HMV 45, 70, 95, 140, 200, 300

ITEM	NAME	MATERIAL	AISI/ASTM
1	Motor	-	-
2	Bracket	Ductile cast iron	ASTM A536 65-45-12
3	Seal base	Stainless steel	AISI 304
4	Mechanical seal	TC/Graphite/Viton®	-
5	Top diffuser	Stainless steel	AISI 304
6	Diffuser	Stainless steel	AISI 304
7	Support diffuser	Stainless steel	AISI 304
8	Coupling	Ductile iron	ASTM A536 65-45-12
9	Impeller	Stainless steel	AISI 304
10	Cylinder	Stainless steel	AISI 304
11	Shaft	Stainless steel	AISI 304
12	Bearing	Tungsten carbide	-
13	Inducer	Stainless steel	AISI 304
14	Inlet & outlet chamber	Stainless steel	AISI 304
15	Base	Cast iron	ASTM 25B

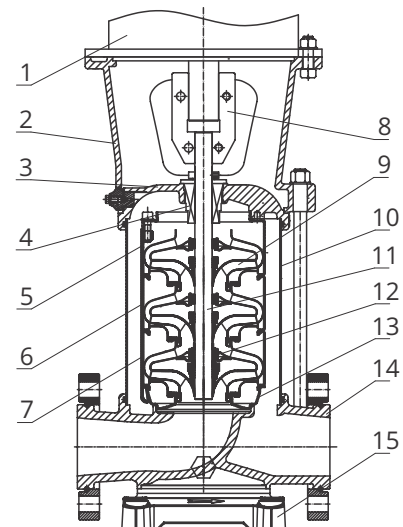

HMV 140, 200, 300



# PERFORMANCE CURVES & DIMENSIONS HMV5

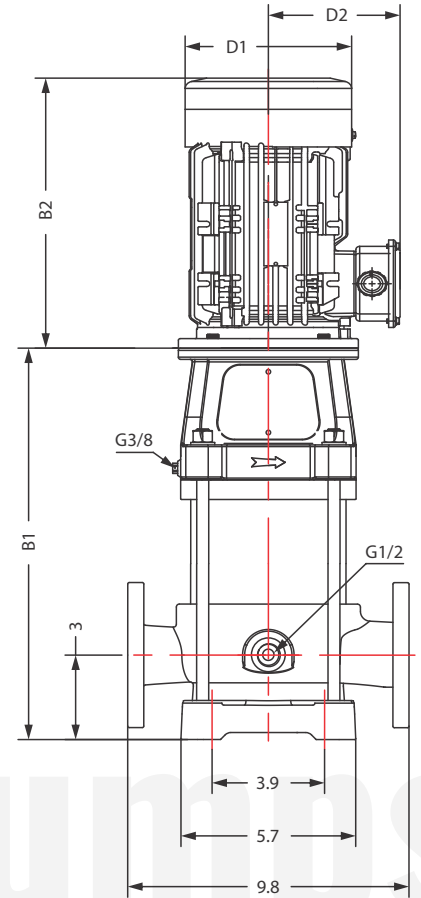
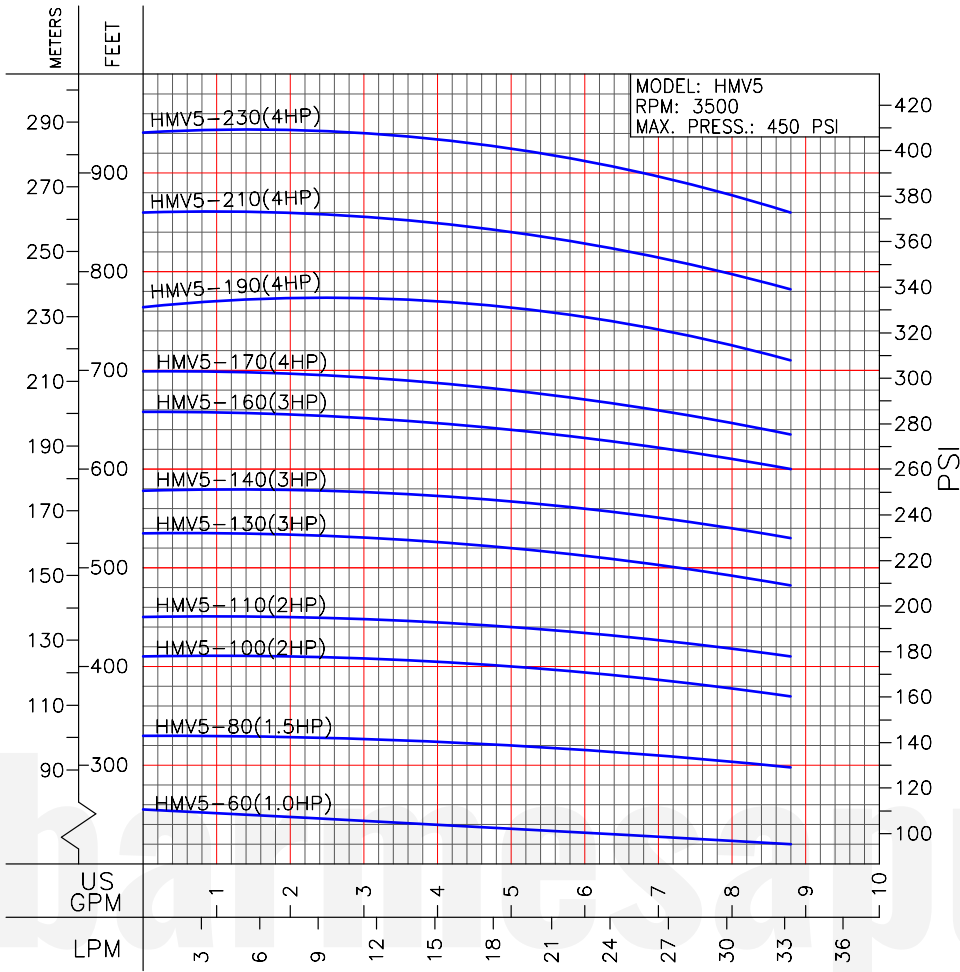

1 1/4" / ANSI / CLASS 300

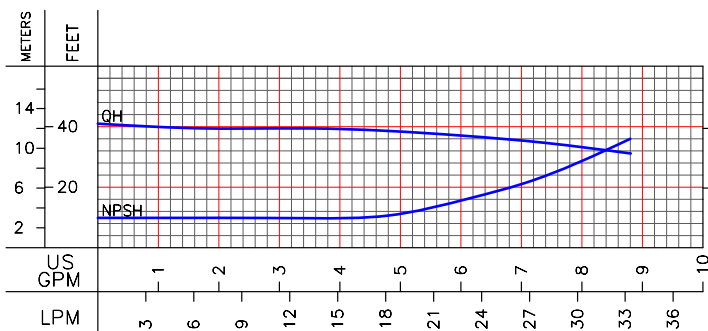
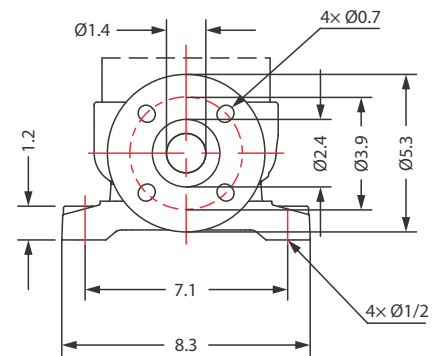
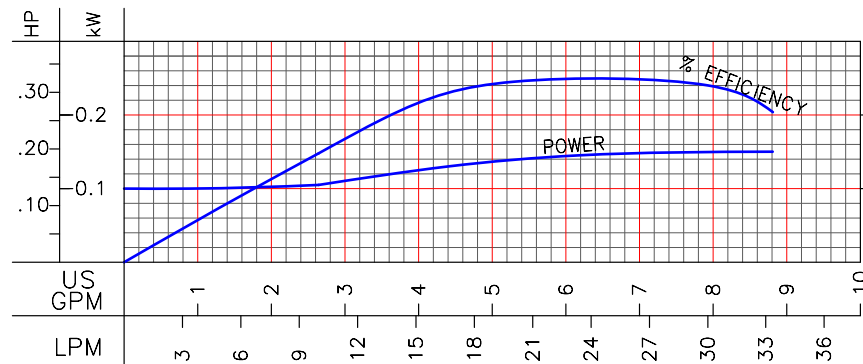

MODEL	HP	STAGES	SIZE (in)				WEIGHT (lb)	
			B1	B2	B1+B2	D1		D2
HMV5-60-103	1	6	14	11	25	7	6	66
HMV5-80-153	1.5	8	15	11	26	7	6	75
HMV5-100-203	2	10	17	14	31	7	6	90
HMV5-110-203	2	11	17	14	31	7	6	90
HMV5-130-303	3	13	19	14	33	7	6	101
HMV5-140-303	3	14	20	14	33	7	6	104
HMV5-160-303	3	16	21	14	35	7	6	108
HMV5-170-403	4	17	22	16	38	8	6	121
HMV5-190-403	4	19	24	16	40	8	6	123
HMV5-210-403	4	21	25	16	41	8	6	128
HMV5-230-403	4	23	26	16	43	8	6	132

# PERFORMANCE CURVES & DIMENSIONS HMV14

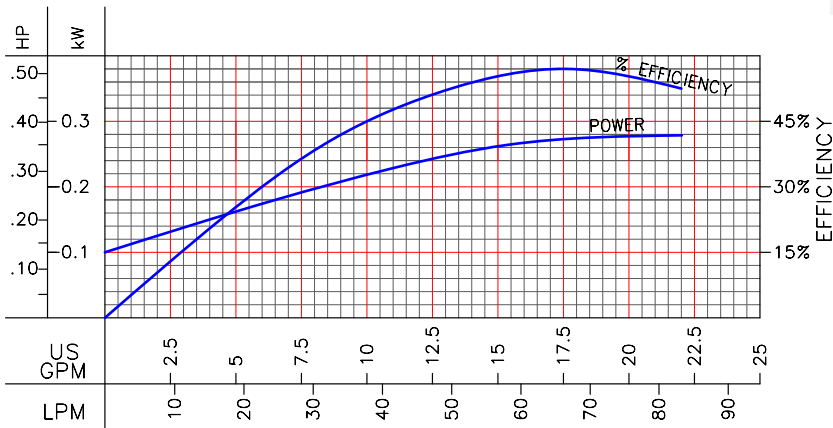
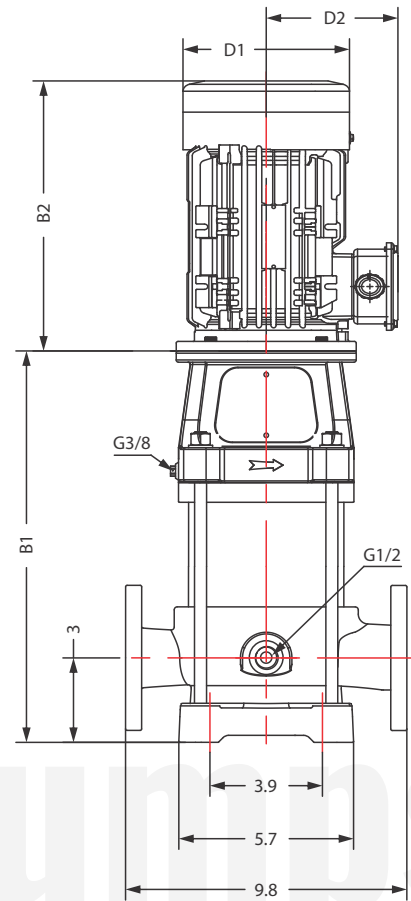
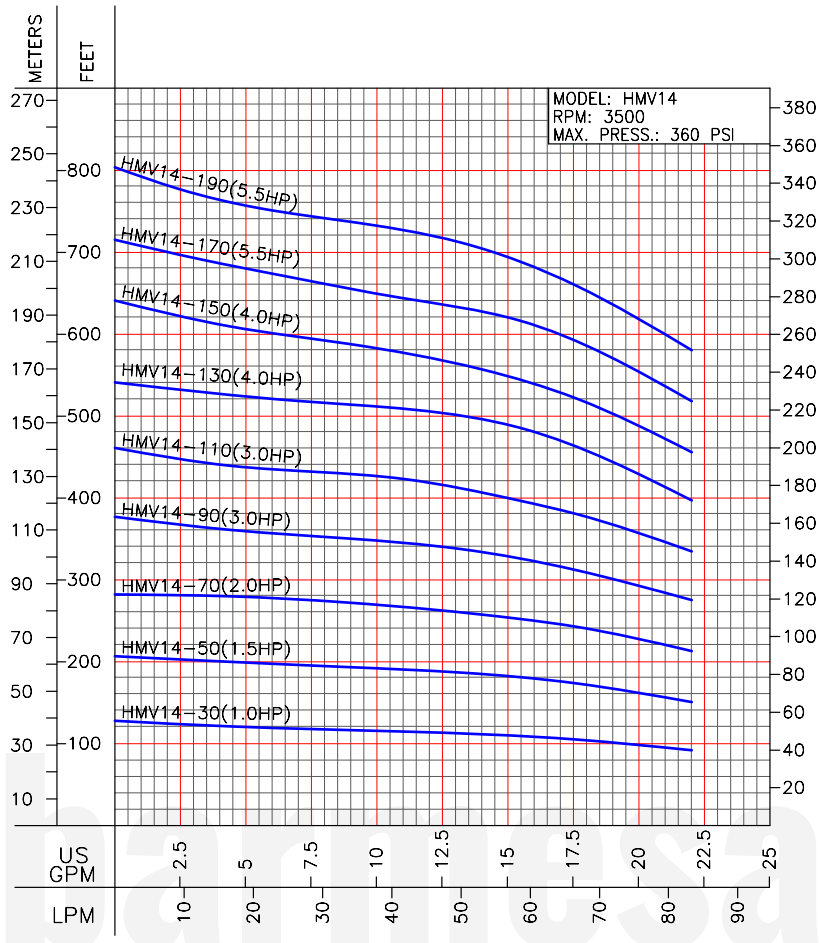

1 1/4" / ANSI / CLASS 300

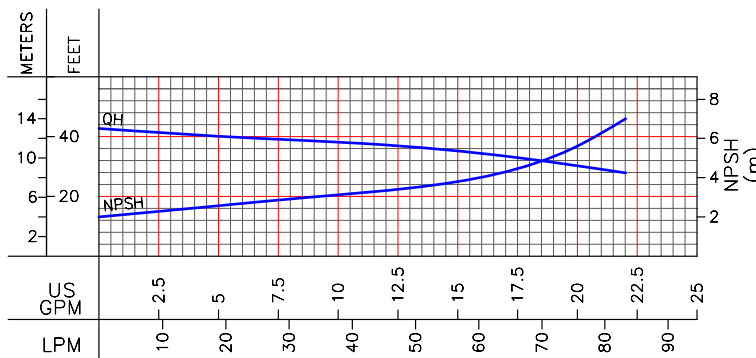
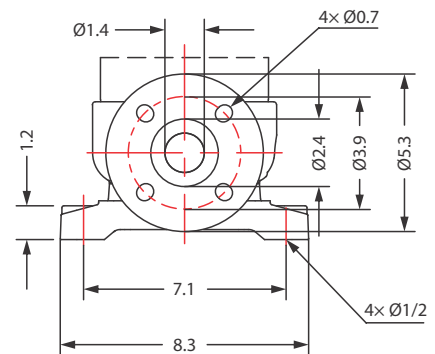

MODEL	HP	STAGES	SIZE (in)			D1	D2	WEIGHT (lb)
			B1	B2	B1+B2			
HMV14-30-103	1	3	11	11	22	7	6	64
HMV14-50-153	1.5	5	13	11	24	7	6	71
HMV14-70-203	2	7	15	14	28	7	6	86
HMV14-90-303	3	9	16	14	30	7	6	101
HMV14-110-303	3	11	17	14	31	7	6	106
HMV14-130-403	4	13	19	16	35	8	6	119
HMV14-150-403	4	15	21	16	37	8	6	123
HMV14-170-553	5	17	22	16	38	9	7	130
HMV14-190-553	5	19	24	16	40	9	7	132

# PERFORMANCE CURVES & DIMENSIONS HMV22

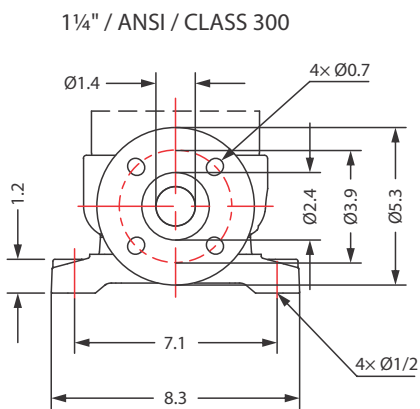
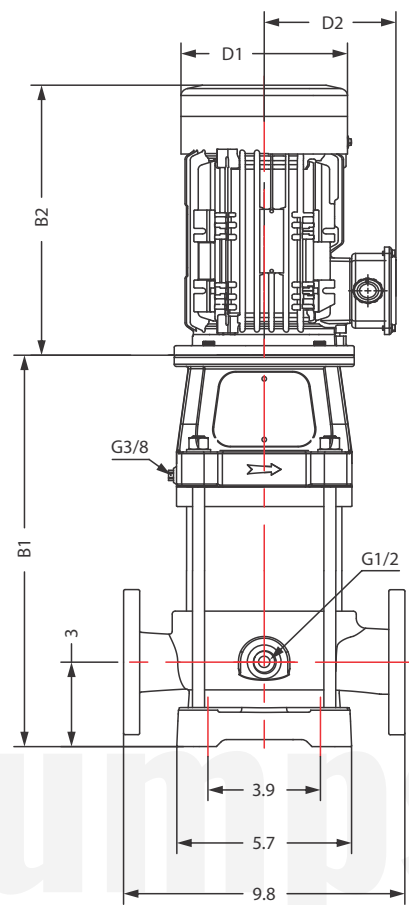
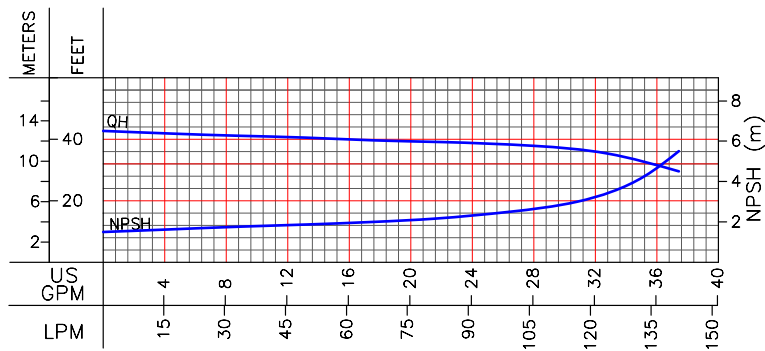
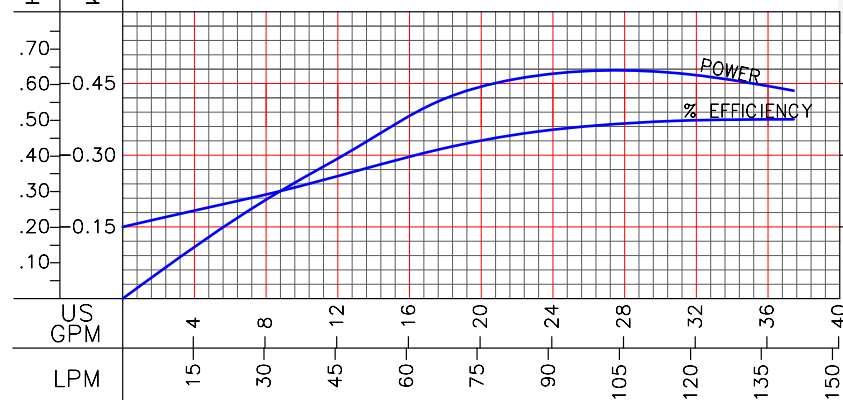
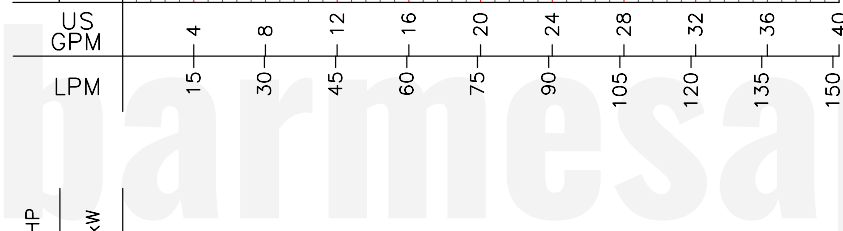
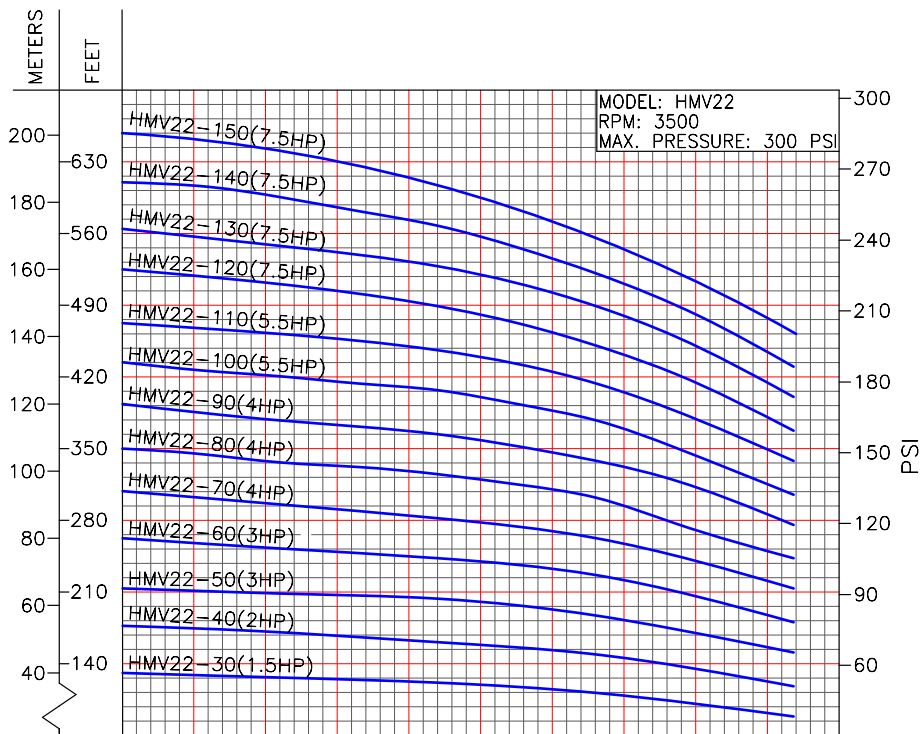

MODEL	HP	STAGES	SIZE (in)				WEIGHT (lb)	
			B1	B2	B1+B2	D1		D2
HMV22-30-153	1.5	3	12	11	24	7	6	71
HMV22-40-203	2	4	14	14	28	7	6	77
HMV22-60-303	3	6	16	14	30	7	6	86
HMV22-90-403	4	9	20	16	36	8	6	104
HMV22-110-553	5	11	22	16	38	9	7	123
HMV22-150-753	7.5	15	27	18	45	10	8	148

# PERFORMANCE CURVES & DIMENSIONS HMV45

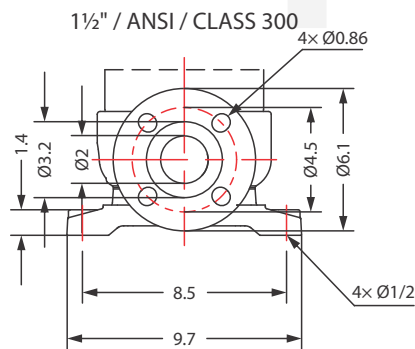
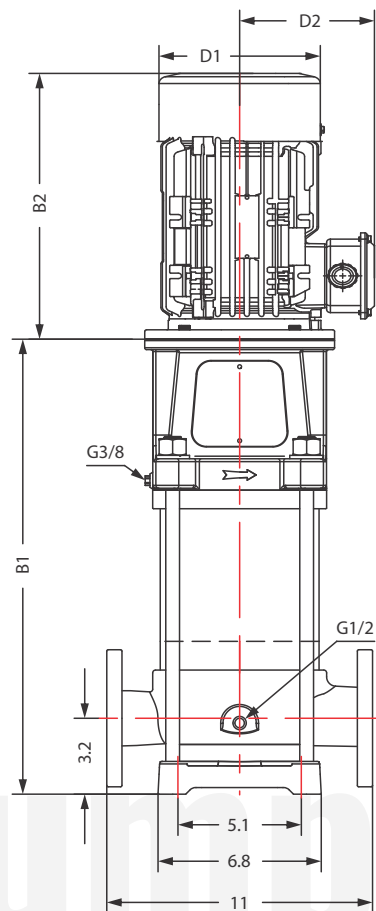
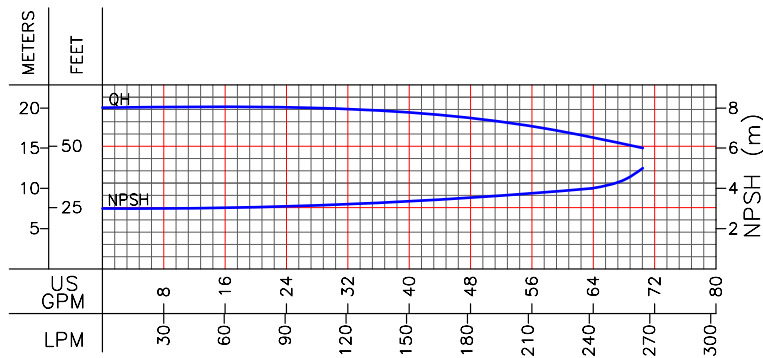
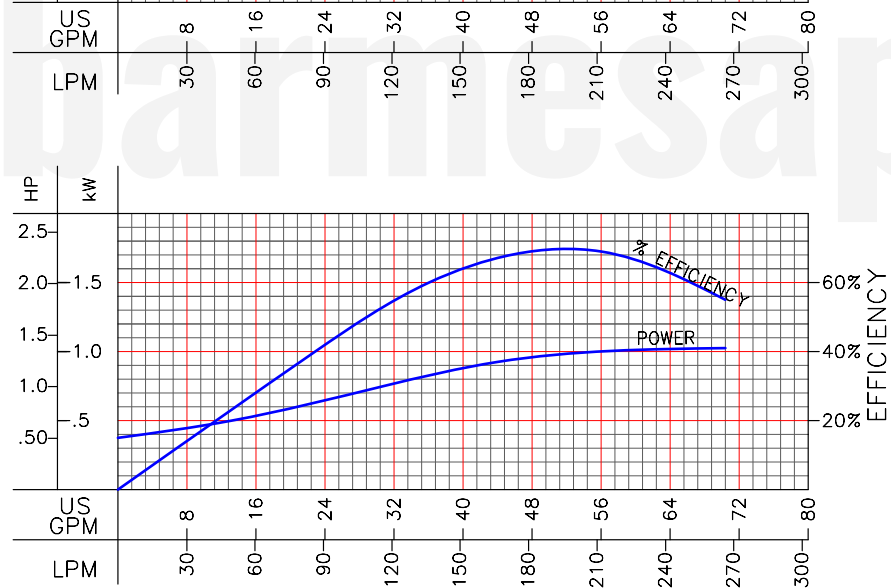
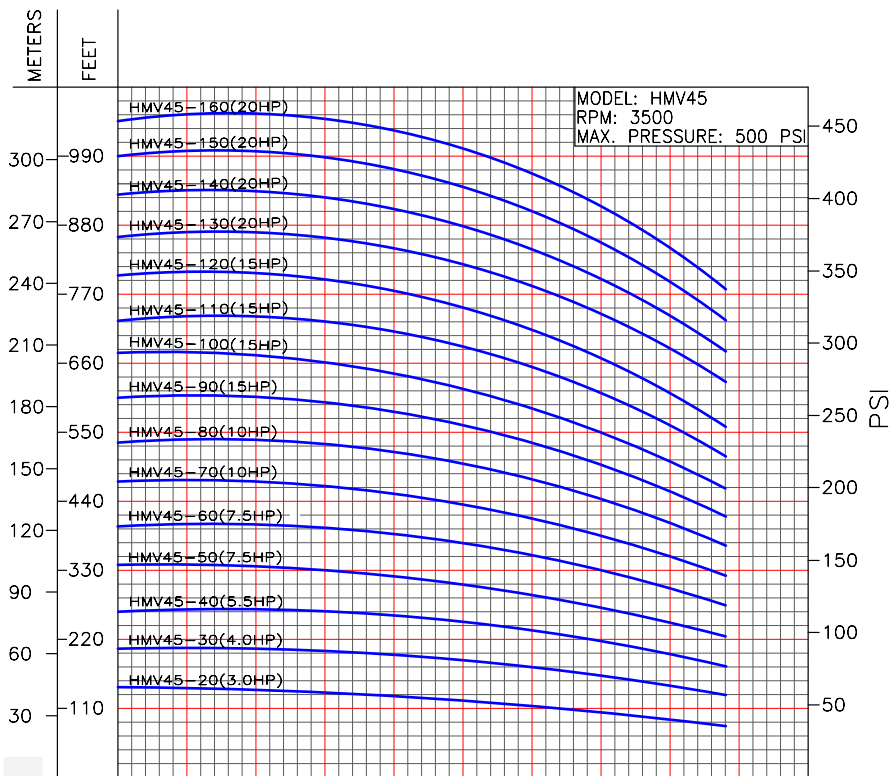

MODEL	HP	STAGES	SIZE (in)				WEIGHT (lb)	
			B1	B2	B1+B2	D1		D2
HMV45-20-303	3	2	14	14	28	7	6	93
HMV45-30-403	4	3	16	16	32	8	6	106
HMV45-40-553	5	4	17	16	33	9	7	128
HMV45-50-753	7.5	5	19	18	37	10	8	154
HMV45-60-753	7.5	6	20	18	39	10	8	157
HMV45-70-1003	10	7	21	18	40	10	8	176
HMV45-80-1003	10	8	23	18	41	10	8	179
HMV45-90-1503	15	9	27	24	51	14	10	335
HMV45-100-1503	15	10	28	24	52	14	10	335
HMV45-110-1503	15	11	30	24	54	14	10	337
HMV45-120-1503	15	12	31	24	55	14	10	340
HMV45-130-2003	20	13	32	24	56	14	10	379
HMV45-140-2003	20	14	33	24	57	14	10	381
HMV45-150-2003	20	15	34	24	58	14	10	384
HMV45-160-2003	20	16	36	24	60	14	10	386

# PERFORMANCE CURVES & DIMENSIONS HMV70

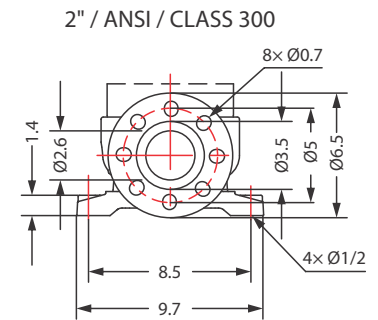
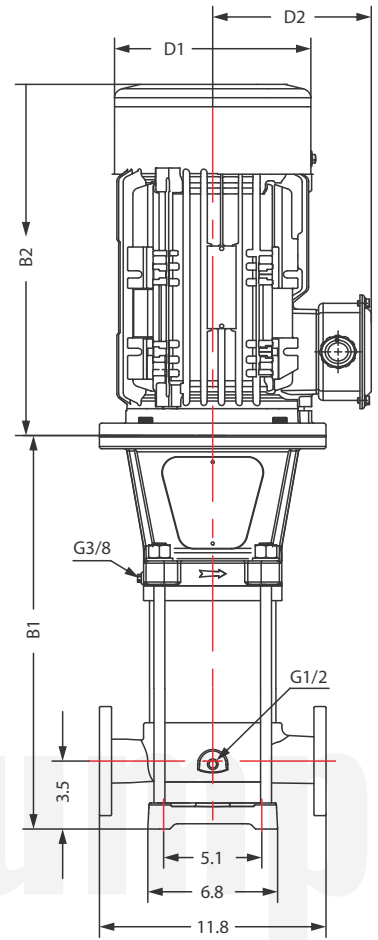
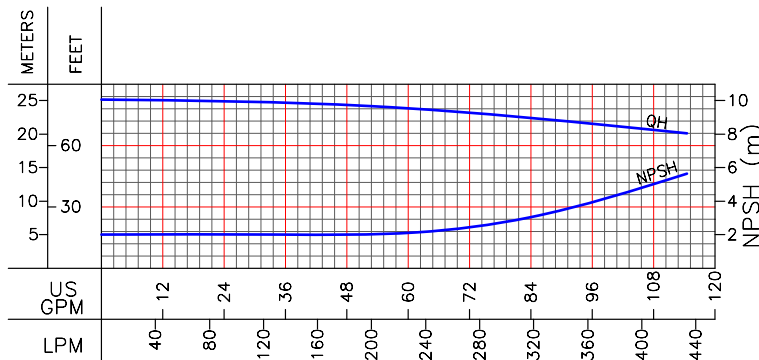
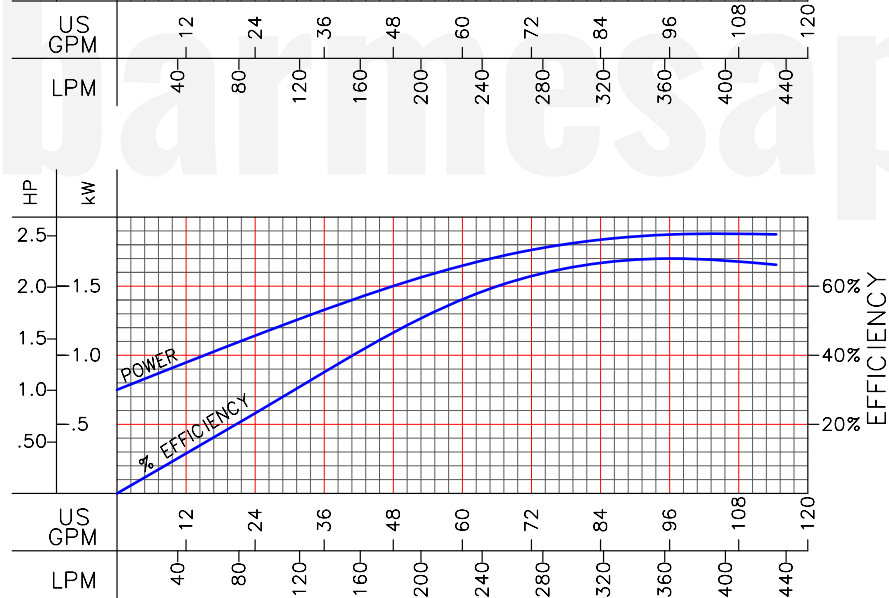
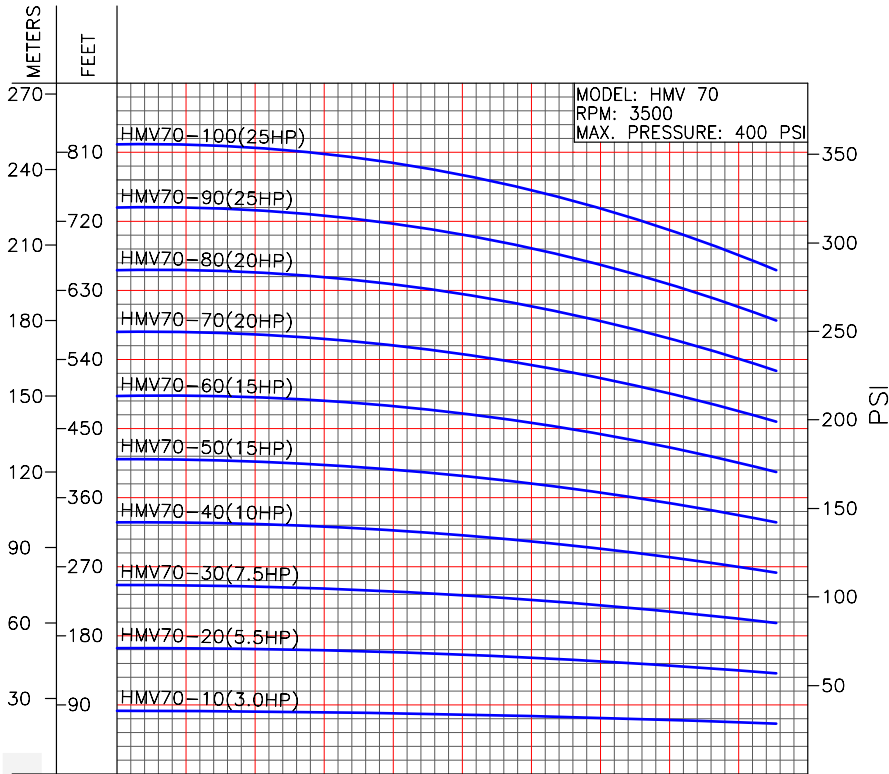

MODEL	HP	STAGES	SIZE (in)				WEIGHT (lb)	
			B1	B2	B1+B2	D1		D2
HMV70-10-303	3	1	14	14	28	7	6	68
HMV70-20-553	5	2	16	16	32	9	7	106
HMV70-30-753	7.5	3	19	18	37	10	8	159
HMV70-40-1003	10	4	21	18	39	10	8	181
HMV70-50-1503	15	5	26	24	50	14	10	331
HMV70-60-1503	15	6	28	24	52	14	10	335
HMV70-70-2003	20	7	29	24	53	14	10	364
HMV70-80-2003	20	8	31	24	55	14	10	366
HMV70-90-2503	25	9	33	25	58	14	10	403
HMV70-100-2503	25	10	35	25	60	14	10	406

# PERFORMANCE CURVES & DIMENSIONS HMV95

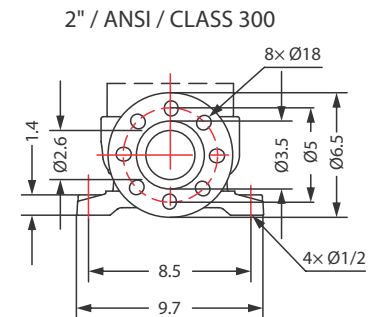
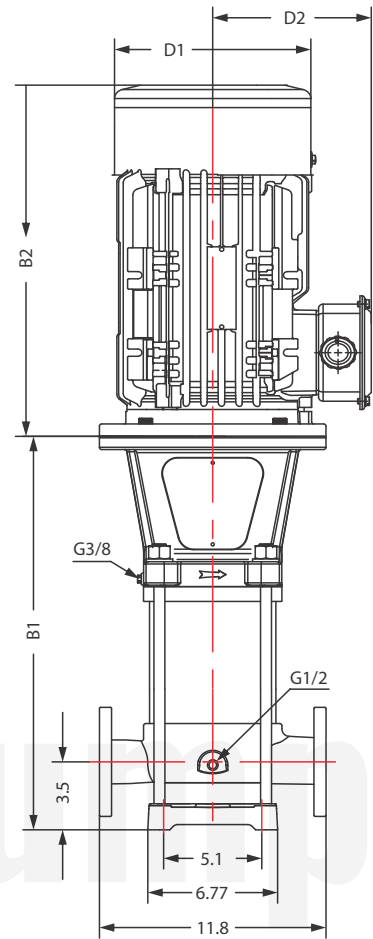
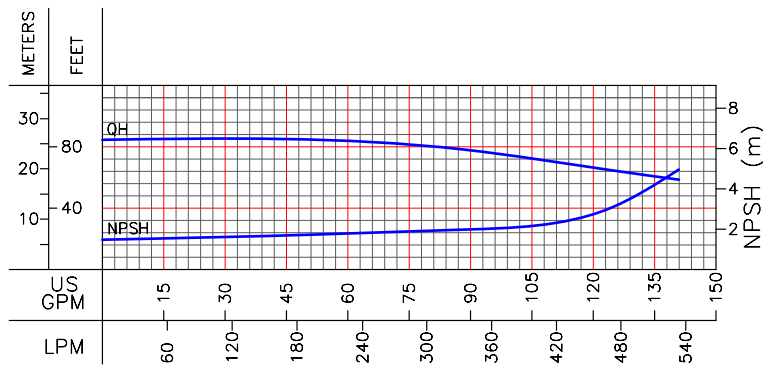
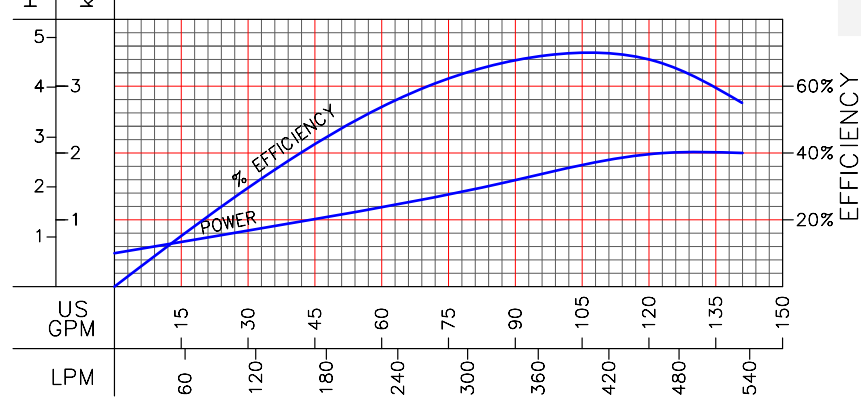
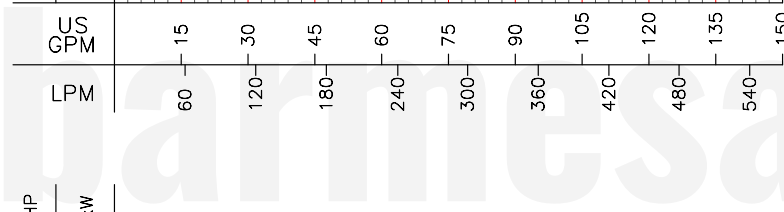
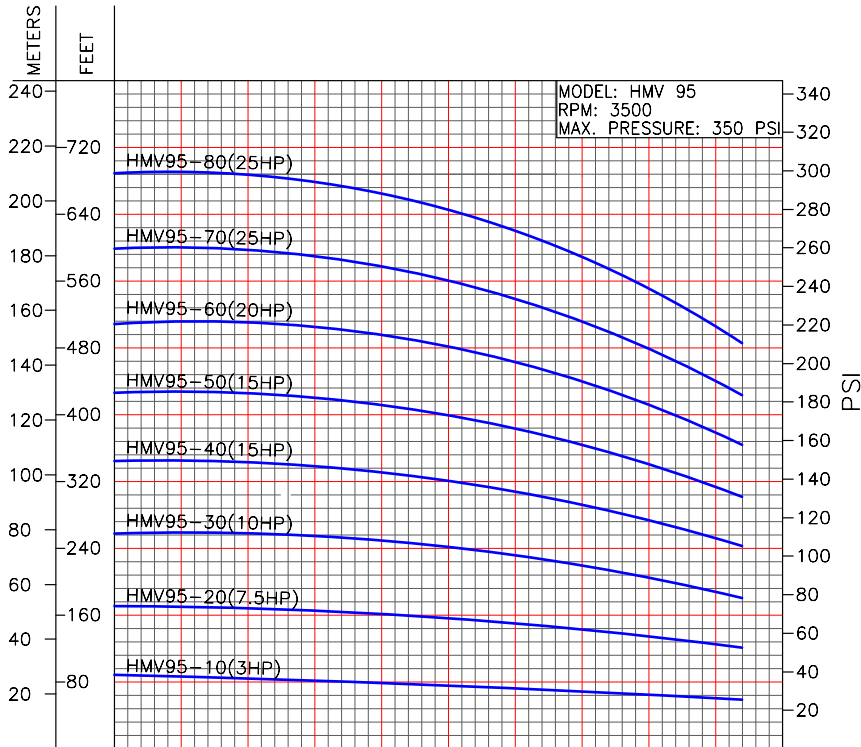

MODEL	HP	STAGES	SIZE (in)				WEIGHT (lb)	
			B1	B2	B1+B2	D1		D2
HMV95-10-303	3	1	14	14	28	7	6	82
HMV95-20-753	7.5	2	17	18	35	10	8	154
HMV95-30-1003	10	3	19	18	37	10	8	168
HMV95-40-1503	15	4	24	24	48	14	10	320
HMV95-50-1503	15	5	26	24	50	14	10	322
HMV95-60-2003	20	6	28	24	52	14	10	324
HMV95-70-2503	25	7	29	25	54	14	10	357
HMV95-80-2503	25	8	31	25	56	14	10	362

# PERFORMANCE CURVES & DIMENSIONS HMV140

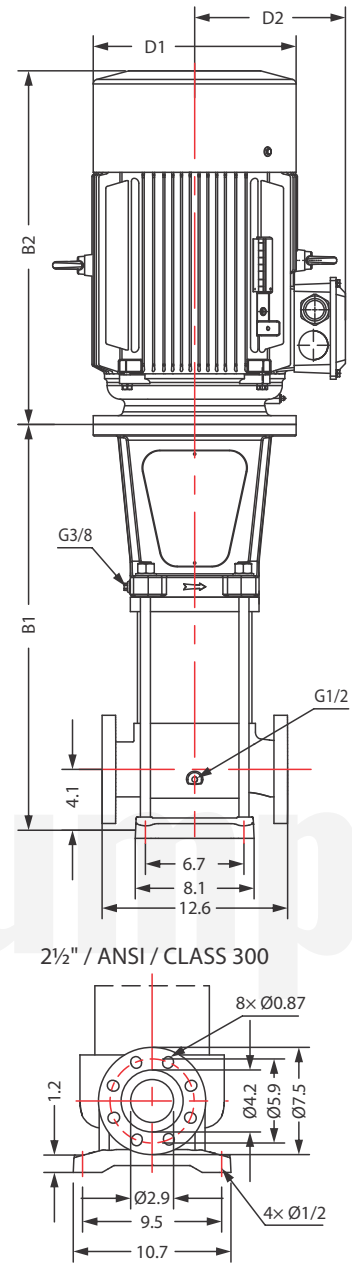
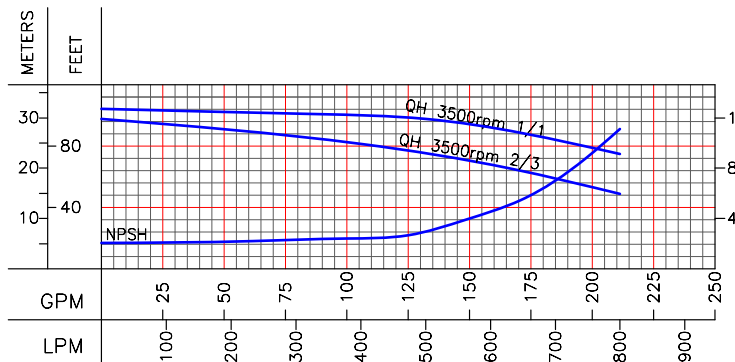
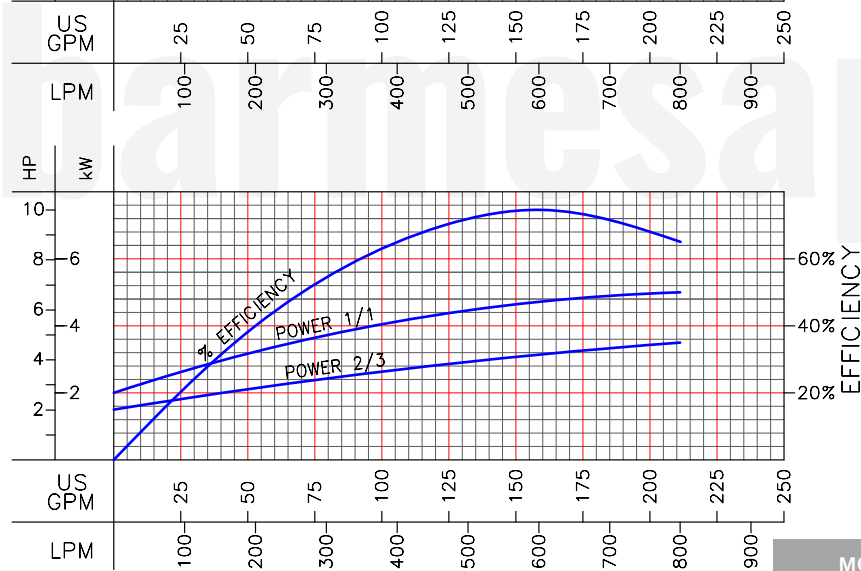
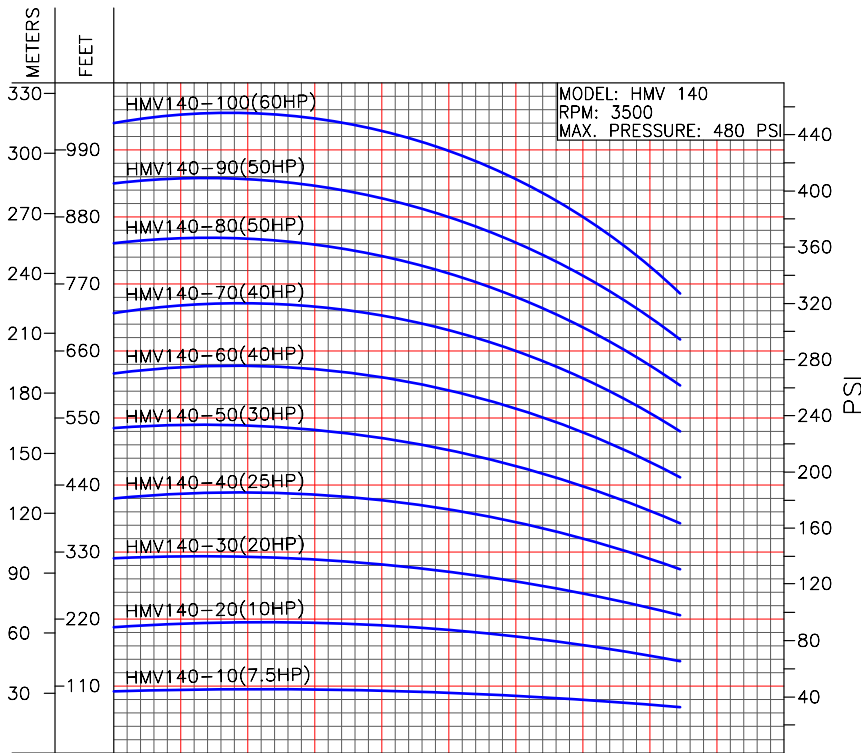

MODEL	HP	STAGES	SIZE (in)					WEIGHT (lb)
			B1	B2	B1+B2	D1	D2	
HMV140-10-1-553	5	1	18	16	34	9	7	176
HMV140-10-753	7.5	1	18	18	37	10	8	229
HMV140-20-2-1003	10	2	21	18	39	10	8	251
HMV140-20-1003	10	2	21	18	39	10	8	251
HMV140-30-2-1503	15	3	28	24	52	14	10	408
HMV140-30-2003	20	3	28	24	52	14	10	437
HMV140-40-2-2003	20	4	30	24	54	14	10	441
HMV140-40-2503	25	4	30	25	56	14	10	476
HMV140-50-2-2503	25	5	33	25	58	14	10	481
HMV140-50-3003	30	5	33	25	58	14	11	492
HMV140-60-2-3003	30	6	36	28	64	14	11	496
HMV140-60-4003	40	6	36	28	64	16	12	518
HMV140-70-2-4003	40	7	39	28	67	16	12	522
HMV140-70-4003	40	7	39	28	67	16	12	522
HMV140-80-5003	50	8	41	28	69	16	12	578
HMV140-90-2-5003	50	9	44	28	72	16	12	582
HMV140-90-5003	50	9	44	28	72	16	12	582
HMV140-100-2-6003	60	10	47	29	76	18	13	743
HMV140-100-6003	60	10	47	29	76	18	13	743

# PERFORMANCE CURVES & DIMENSIONS HMV140-2

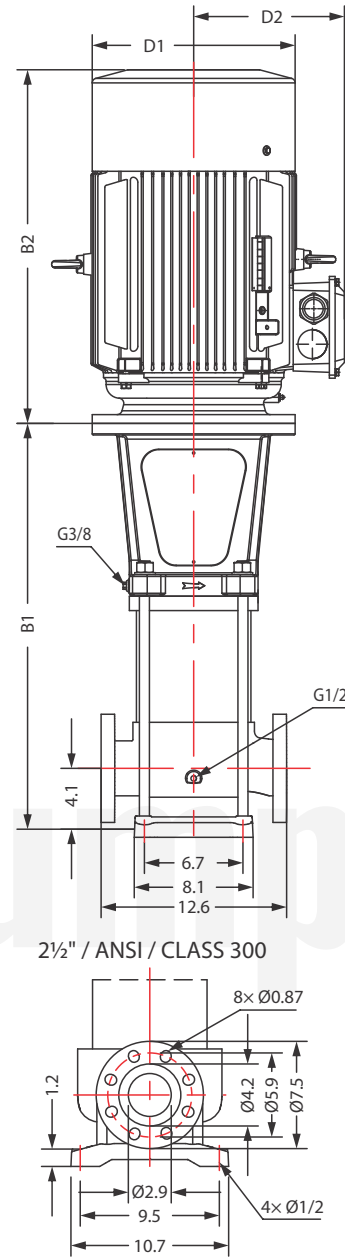
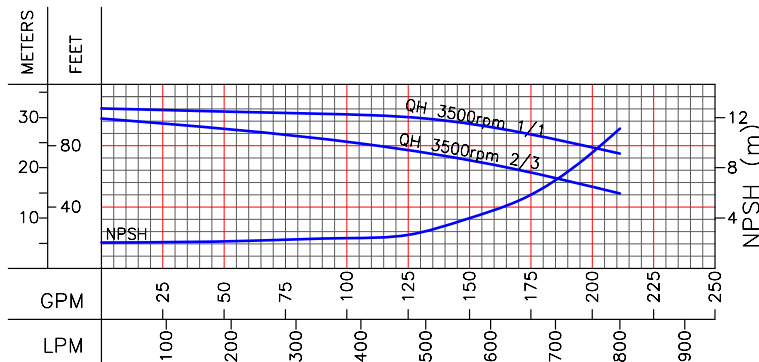
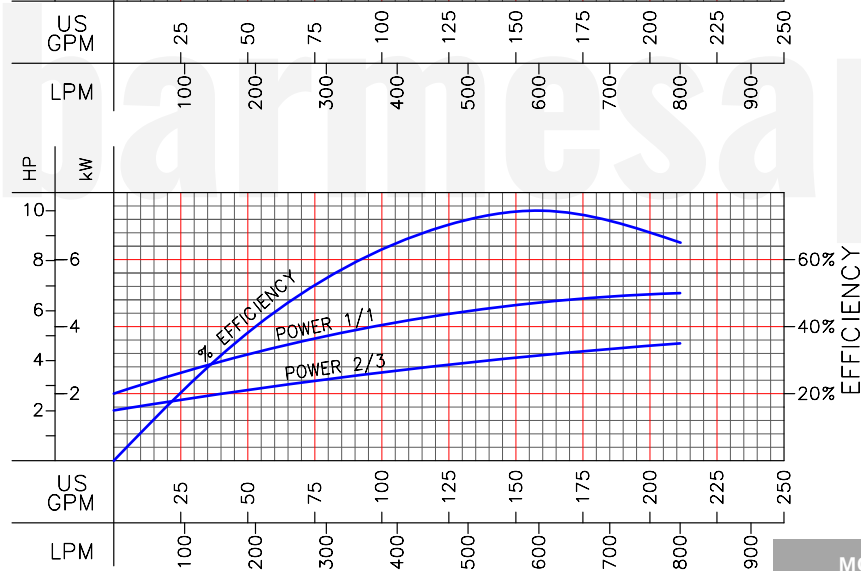
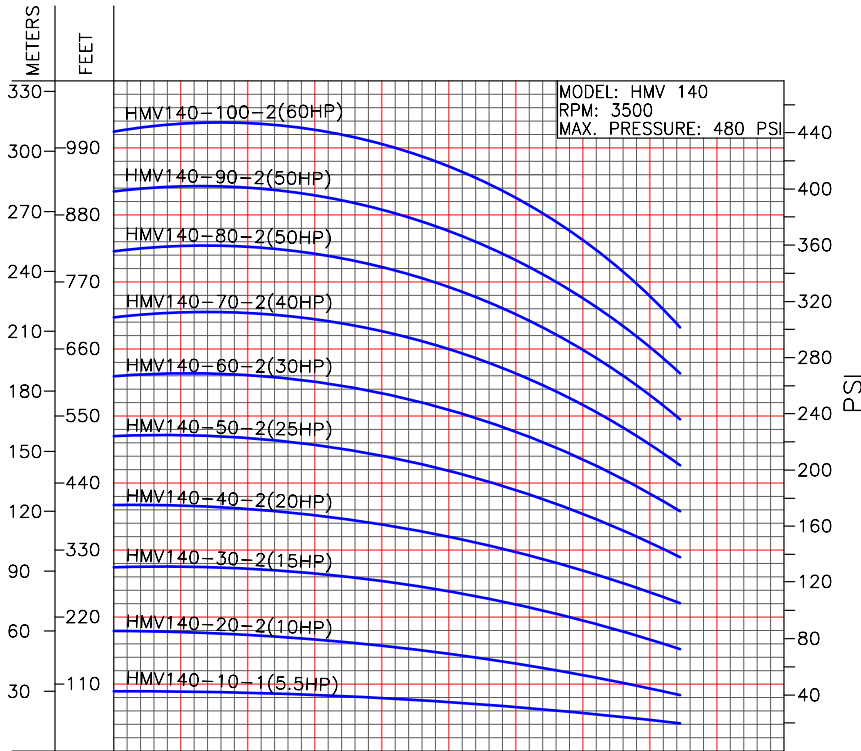

MODEL	HP	STAGES	SIZE (in)					WEIGHT (lb)
			B1	B2	B1+B2	D1	D2	
HMV140-10-1-553	5	1	18	16	34	9	7	176
HMV140-10-753	7.5	1	18	18	37	10	8	229
HMV140-20-2-1003	10	2	21	18	39	10	8	251
HMV140-20-1003	10	2	21	18	39	10	8	251
HMV140-30-2-1503	15	3	28	24	52	14	10	408
HMV140-30-2003	20	3	28	24	52	14	10	437
HMV140-40-2-2003	20	4	30	24	54	14	10	441
HMV140-40-2503	25	4	30	25	56	14	10	476
HMV140-50-2-2503	25	5	33	25	58	14	10	481
HMV140-50-3003	30	5	33	25	58	14	11	492
HMV140-60-2-3003	30	6	36	28	64	14	11	496
HMV140-60-4003	40	6	36	28	64	16	12	518
HMV140-70-2-4003	40	7	39	28	67	16	12	522
HMV140-70-4003	40	7	39	28	67	16	12	522
HMV140-80-5003	50	8	41	28	69	16	12	578
HMV140-90-2-5003	50	9	44	28	72	16	12	582
HMV140-90-5003	50	9	44	28	72	16	12	582
HMV140-100-2-6003	60	10	47	29	76	18	13	743
HMV140-100-6003	60	10	47	29	76	18	13	743



# PERFORMANCE CURVES & DIMENSIONS HMV200

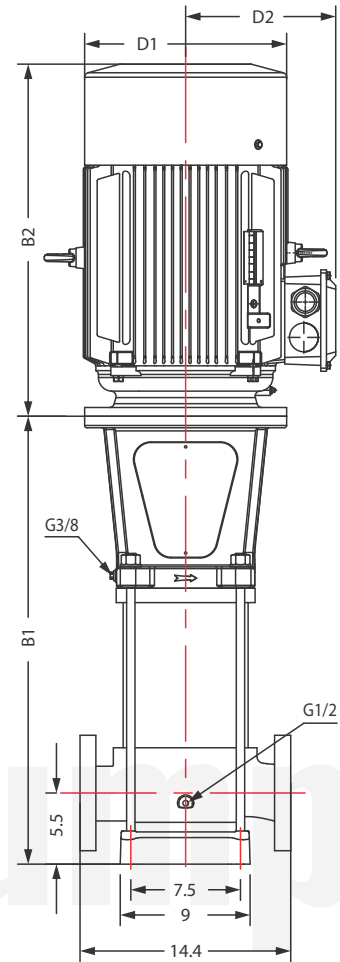
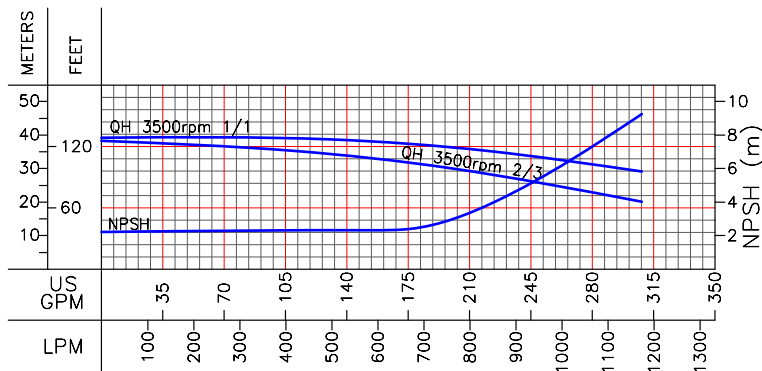
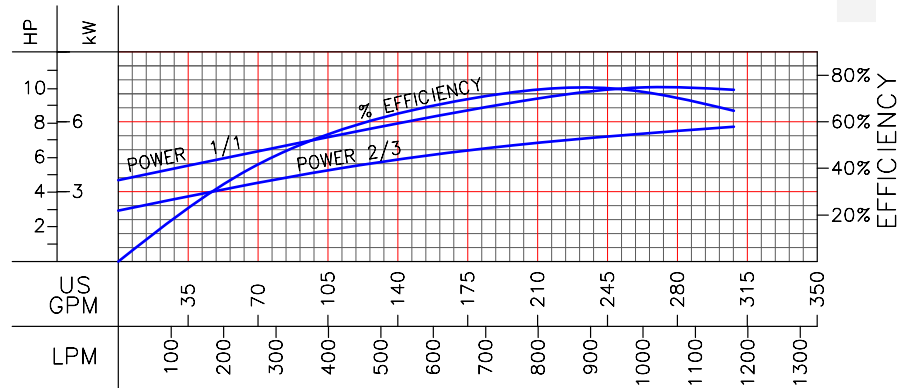
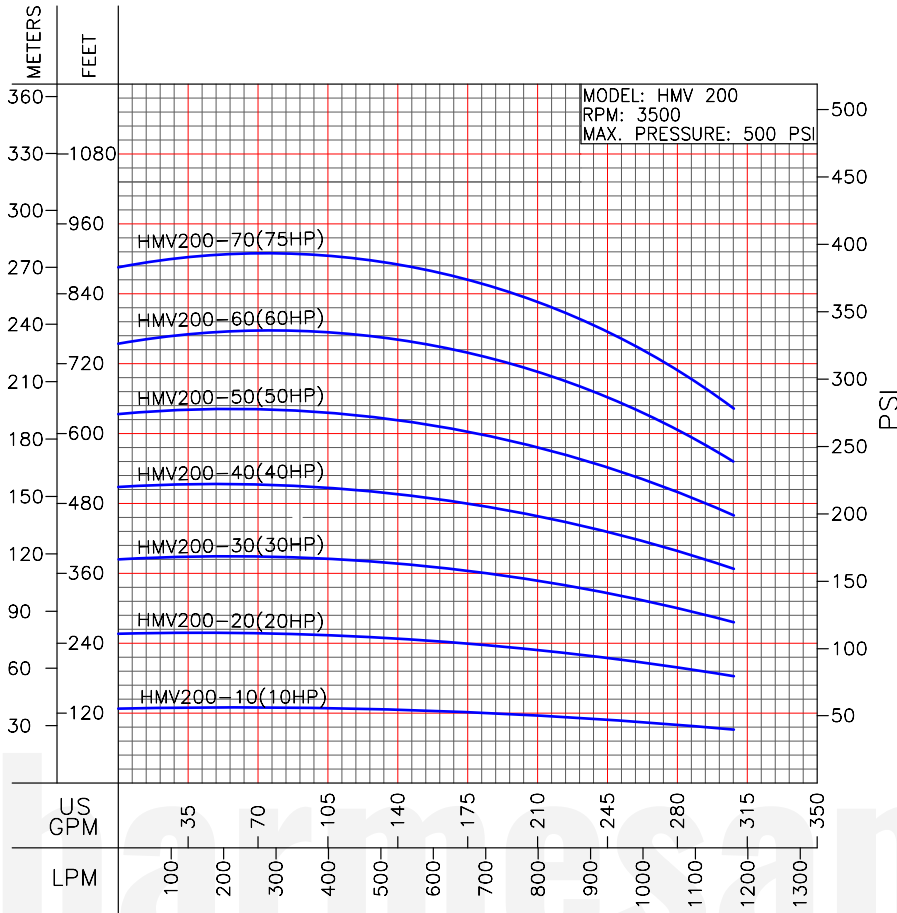

3" / ANSI / CLASS 300

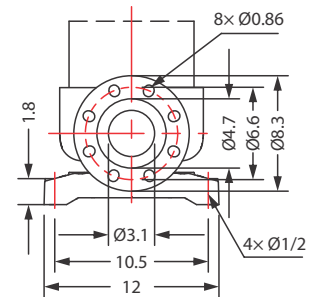

MODEL	HP	STAGES	SIZE (in)				WEIGHT (lb)	
			B1	B2	B1+B2	D1		D2
HMV200-10-1-1003	10	1	20	18	38	10	8	227
HMV200-10-1-1003	10	1	20	18	38	10	8	249
HMV200-20-2-2003	20	2	27	24	51	14	10	452
HMV200-30-2-2503	25	3	31	25	56	14	10	496
HMV200-30-3-3003	30	3	31	26	57	14	11	573
HMV200-40-4-4003	40	4	34	28	62	16	12	694
HMV200-50-5-5003	50	5	37	28	65	16	12	750
HMV200-70-2-6003	60	7	43	29	72	18	13	915
HMV200-80-2-7503	75	8	47	32	80	22	15	1091

# PERFORMANCE CURVES & DIMENSIONS HMV200-2

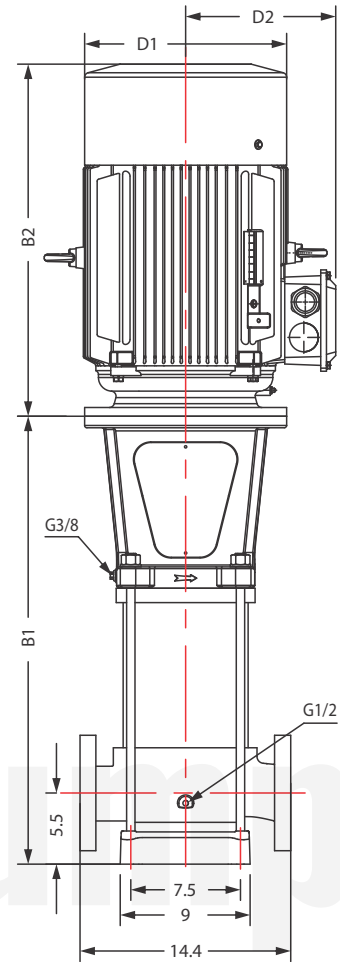
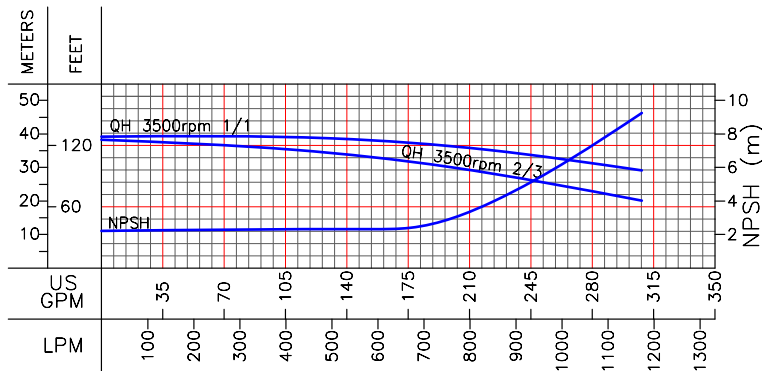
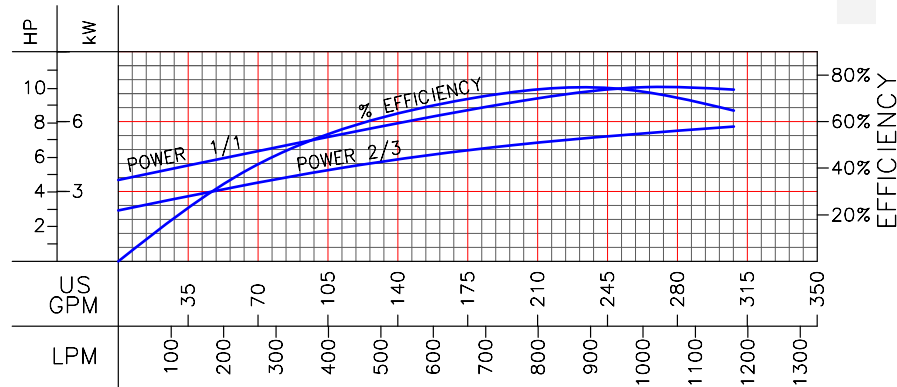
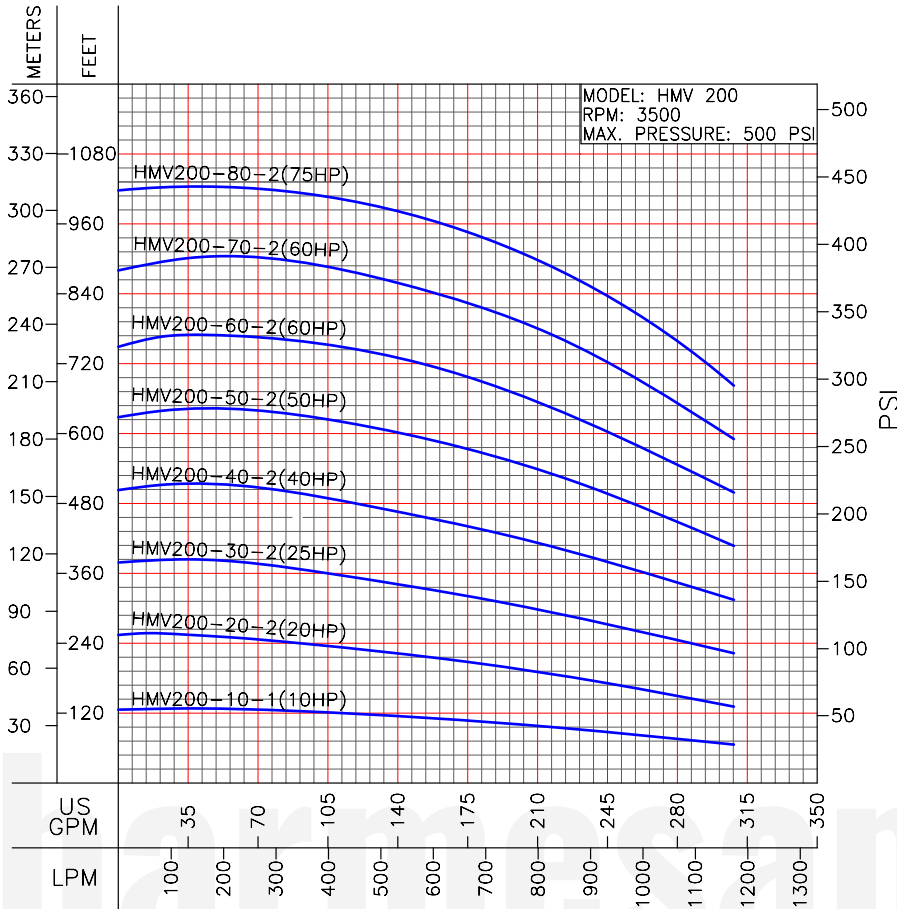

3" / ANSI / CLASS 300

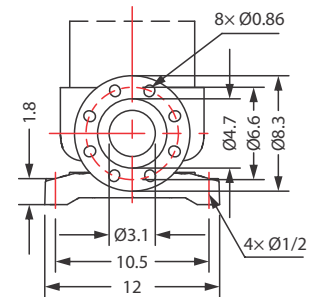

MODEL	HP	STAGES	SIZE (in)				WEIGHT (lb)	
			B1	B2	B1+B2	D1		D2
HMV200-10-1-1003	10	1	20	18	38	10	8	227
HMV200-10-1003	10	1	20	18	38	10	8	249
HMV200-20-2003	20	2	27	24	51	14	10	452
HMV200-30-2-2503	25	3	31	25	56	14	10	496
HMV200-30-3003	30	3	31	26	57	14	11	573
HMV200-40-4003	40	4	34	28	62	16	12	694
HMV200-50-5003	50	5	37	28	65	16	12	750
HMV200-70-2-6003	60	7	43	29	72	18	13	915
HMV200-80-2-7503	75	8	47	32	80	22	15	1091

# PERFORMANCE CURVES & DIMENSIONS HMV300

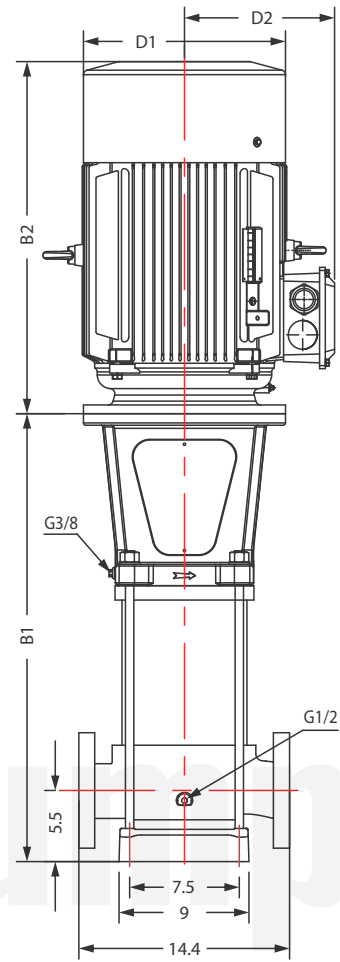
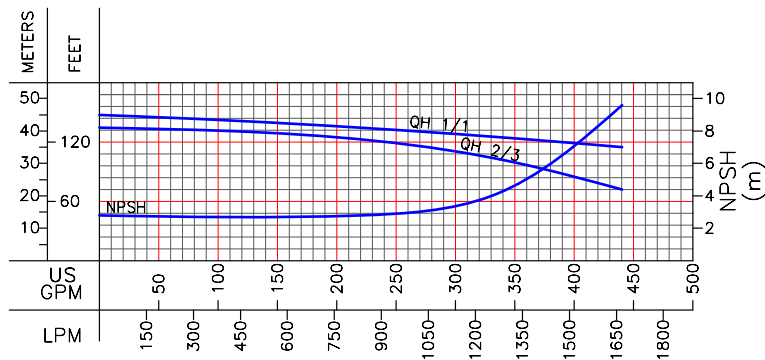
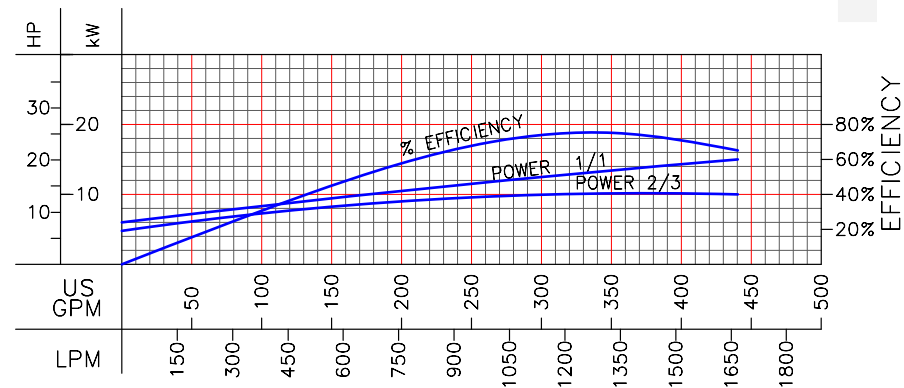
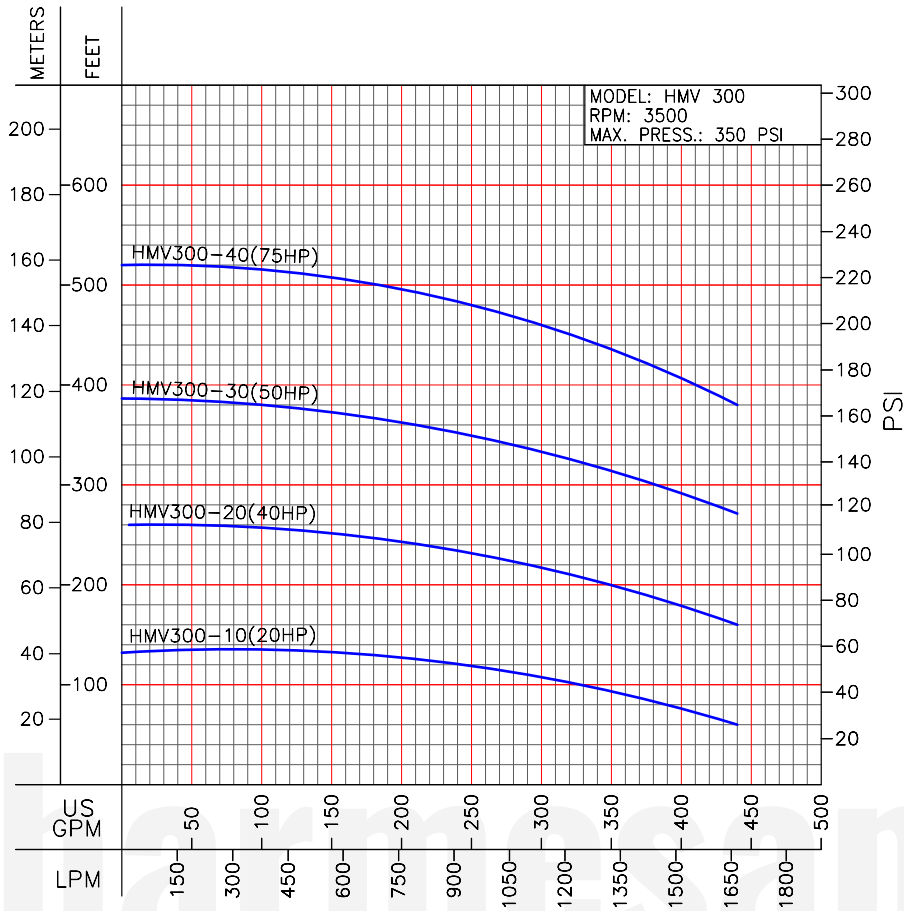

4" / ANSI / CLASS 300

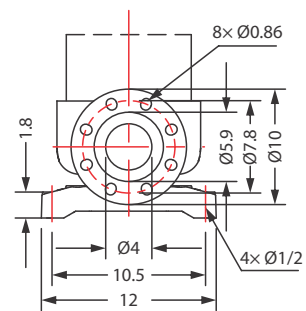

MODEL	HP	STAGES	SIZE (in)			D1	D2	WEIGHT (lb)
			B1	B2	B1+B2			
HMV300-10-1-1503	15	1	24	24	48	14	10	399
HMV300-10-2-2003	20	1	24	24	48	14	10	399
HMV300-20-2-3003	30	2	28	26	54	14	11	573
HMV300-20-4-4003	40	2	28	28	56	16	12	701
HMV300-30-2-4003	40	3	31	3	34	16	12	705
HMV300-30-5-5003	50	3	31	28	59	16	12	772
HMV300-40-2-6003	60	4	34	29	63	18	13	926
HMV300-40-7-7503	75	4	35	32	68	22	15	1124
HMV300-50-2-7503	75	5	39	32	71	22	15	1129

# PERFORMANCE CURVES & DIMENSIONS HMV300-2

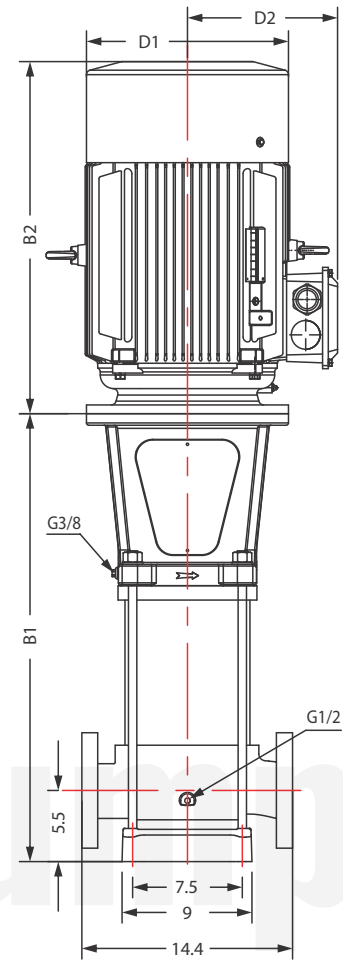
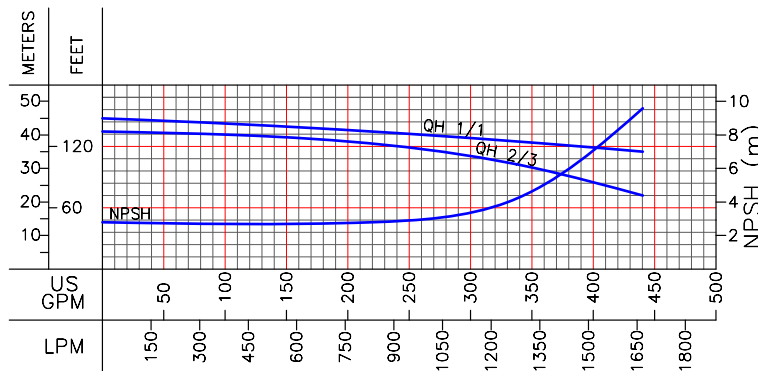
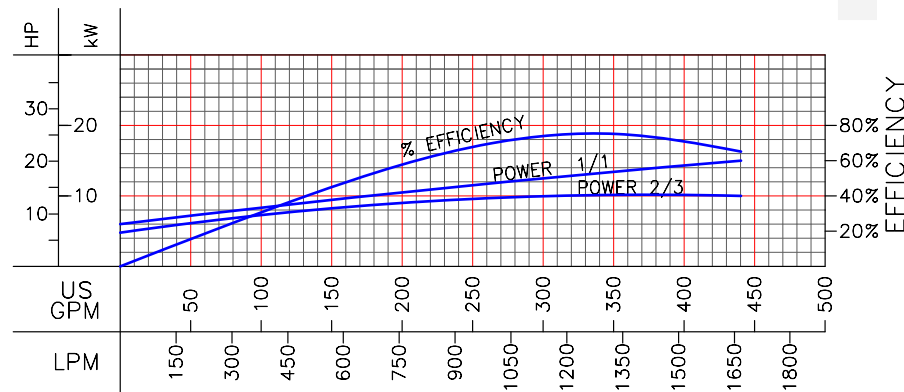
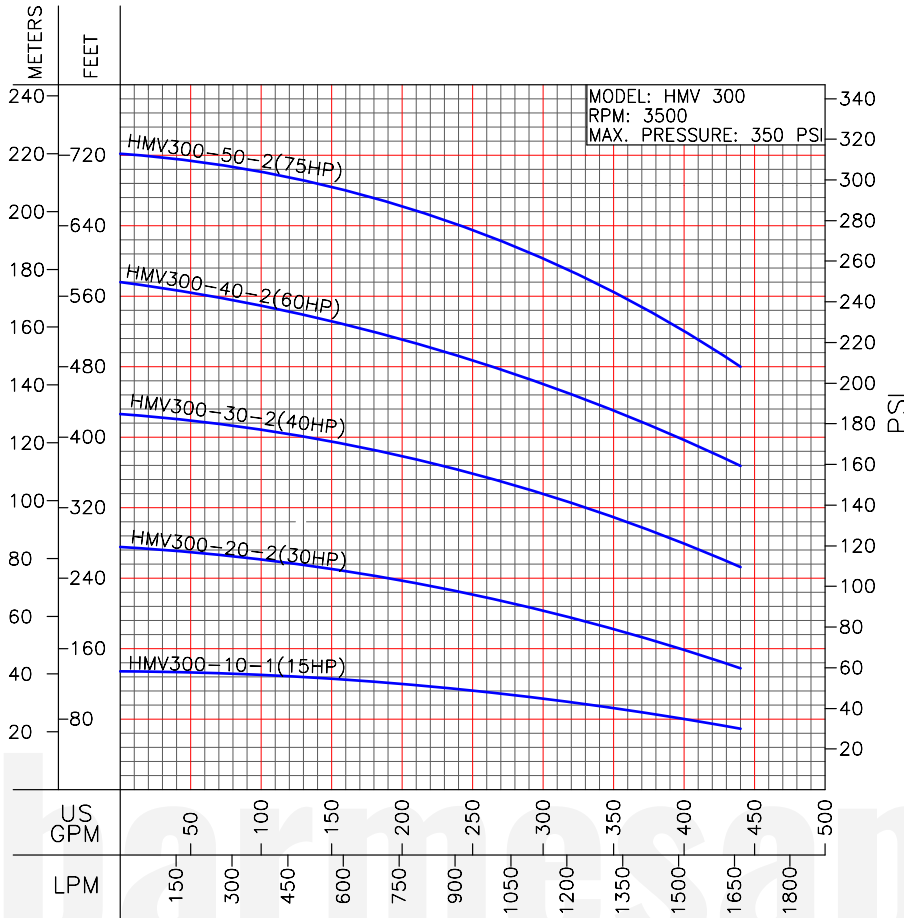

4" / ANSI / CLASS 300

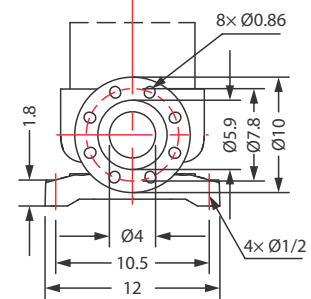

MODEL	HP	STAGES	SIZE (in)			D1	D2	WEIGHT (lb)
			B1	B2	B1+B2			
HMV300-10-1-1503	15	1	24	24	48	14	10	399
HMV300-10-2003	20	1	24	24	48	14	10	399
HMV300-20-2-3003	30	2	28	26	54	14	11	573
HMV300-20-4003	40	2	28	28	56	16	12	701
HMV300-30-2-4003	40	3	31	3	34	16	12	705
HMV300-30-5003	50	3	31	28	59	16	12	772
HMV300-40-2-6003	60	4	34	29	63	18	13	926
HMV300-40-7503	75	4	35	32	68	22	15	1124
HMV300-50-2-7503	75	5	39	32	71	22	15	1129

TECHNICAL DATA								
MODEL	PART No.	HP	RPM	V	MAX. AMPS	MAX. TEMP. (°F)	MAX. Q (gpm)	MAX. H (ft)
HMV5-60-103	70120101A	1	3500	230/460	2.9/1.5	248	8.5	245
HMV5-80-153	70120101B	1.5	3500	230/460	4.2/2.1	248	8.5	328
HMV5-100-203	70120101H	2	3500	230/460	5.5/2.7	248	8.5	410
HMV5-110-203	70120101C	2	3500	230/460	5.5/2.7	248	8.5	450
HMV5-130-303	70120101J	3	3500	230/460	7.9/3.9	248	8.5	530
HMV5-140-303	70120101L	3	3500	230/460	7.9/3.9	248	8.5	574
HMV5-160-303	70120101D	3	3500	230/460	7.9/3.9	248	8.5	656
HMV5-170-403	70120101N	4	3500	230/460	10.3/5.1	248	8.5	695
HMV5-190-403	70120101P	4	3500	230/460	10.3/5.1	248	8.5	777
HMV5-210-403	70120101R	4	3500	230/460	10.3/5.1	248	8.5	860
HMV5-230-403	70120101E	4	3500	230/460	10.3/5.1	248	8.5	940
HMV14-30-103	70120103A	1	3500	230/460	2.9/1.5	248	20	130
HMV14-50-153	70120103B	1.5	3500	230/460	4.2/2.1	248	20	203
HMV14-70-203	70120103C	2	3500	230/460	5.5/2.7	248	20	295
HMV14-90-303	70120103L	3	3500	230/460	7.9/3.9	248	20	367
HMV14-110-303	70120103D	3	3500	230/460	7.9/3.9	248	20	459
HMV14-130-403	-	4	3500	230/460	7.9/3.9	248	20	541
HMV14-150-403	70120103E	4	3500	230/460	10.3/5.1	248	20	623
HMV14-170-553	70120103P	5.5	3500	230/460	13.5/6.7	248	20	714
HMV14-190-553	70120103F	5.5	3500	230/460	13.5/6.7	248	20	794
HMV22-30-153	70120105A	1.5	3500	230/460	4.2/2.1	248	35	130
HMV22-40-203	70120105B	2	3500	230/460	5.5/2.7	248	35	170
HMV22-60-303	70120105C	3	3500	230/460	7.9/3.9	248	35	262
HMV22-90-403	70120105D	4	3500	230/460	10.3/5.1	248	35	390
HMV22-110-553	70120105E	5.5	3500	230/460	13.5/6.7	248	35	478
HMV22-150-753	70120105F	7.5	3500	230/460	18.3/9.1	248	35	640
HMV45-20-303	70120107A	3	3500	230/460	7.9/3.9	248	65	137
HMV45-30-403	70120107B	4	3500	230/460	10.3/5.1	248	65	203
HMV45-40-553	70120107C	5.5	3500	230/460	13.5/6.7	248	65	262
HMV45-50-753	70120107H	7.5	3500	230/460	18.3/9.1	248	65	334
HMV45-60-753	70120107D	7.5	3500	230/460	18.3/9.1	248	65	407
HMV45-70-1003	70120107J	10	3500	230/460	24.7/12.3	248	65	460
HMV45-80-1003	70120107E	10	3500	230/460	24.7/12.3	248	65	530
HMV45-90-1503	70120107L	15	3500	230/460	34/17	248	65	592
HMV45-100-1503	70120107N	15	3500	230/460	34/17	248	65	662
HMV45-110-1503	70120107P	15	3500	230/460	34/17	248	65	728
HMV45-120-1503	70120107F	15	3500	230/460	34/17	248	65	787
HMV45-130-2003	70120107R	20	3500	230/460	46/23	248	65	859
HMV45-140-2003	70120107T	20	3500	230/460	46/23	248	65	921
HMV45-150-2003	70120107V	20	3500	230/460	46/23	248	65	996
HMV45-160-2003	70120107G	20	3500	230/460	46/23	248	65	1055
HMV70-10-303	70120109A	3	3500	230/460	7.9/3.9	248	102	82
HMV70-20-553	70120109B	5.5	3500	230/460	13.5/6.7	248	102	164
HMV70-30-753	70120109C	7.5	3500	230/460	18.3/9.1	248	102	246
HMV70-40-1003	70120109D	10	3500	230/460	24.7/12.3	248	102	327
HMV70-50-1503	70120109L	15	3500	230/460	34/17	248	102	409
HMV70-60-1503	70120109E	15	3500	230/460	34/17	248	102	492
HMV70-70-2003	70120109N	20	3500	230/460	46/23	248	102	573

TECHNICAL DATA								
MODEL	PART No.	HP	RPM	V	MAX. AMPS	MAX. TEMP. (°F)	MAX. Q (gpm)	MAX. H (ft)
HMV70-80-2003	70120109F	20	3500	230/460	46/23	248	102	656
HMV70-90-2503	70120109P	25	3500	230/460	56.5/28.2	248	102	738
HMV70-100-2503	70120109G	25	3500	230/460	56.5/28.2	248	102	820
HMV95-10-303	70120111A	3	3500	230/460	7.9/3.9	248	140	82
HMV95-20-753	70120111B	7.5	3500	230/460	18.3/9.1	248	140	180
HMV95-30-1003	70120111C	10	3500	230/460	24.7/12.3	248	140	255
HMV95-40-1503	70120111L	15	3500	230/460	34/17	248	140	340
HMV95-50-1503	70120111D	15	3500	230/460	34/17	248	140	426
HMV95-60-2003	70120111E	20	3500	230/460	46/23	248	140	508
HMV95-70-2503	70120111N	25	3500	230/460	56.5/28.2	248	140	593
HMV95-80-2503	70120111F	25	3500	230/460	56.5/28.2	248	140	681
HMV140-10-1-553	70120113A	5.5	3500	230/460	13.5/6.7	248	200	95
HMV140-10-753	70120113B	7.5	3500	230/460	18.3/9.1	248	200	101
HMV140-20-2-1003	70120113N	10	3500	230/460	24.7/12.3	248	200	197
HMV140-20-1003	70120113C	10	3500	230/460	24.7/12.3	248	200	213
HMV140-30-2-1503	70120113D	15	3500	230/460	34/17	248	200	295
HMV140-30-2003	70120113P	20	3500	230/460	46/23	248	200	327
HMV140-40-2-2003	70120113E	20	3500	230/460	46/23	248	200	400
HMV140-40-2503	70120113R	25	3500	230/460	56.5/28.2	248	200	429
HMV140-50-2-2503	70120113F	25	3500	230/460	56.5/28.2	248	200	508
HMV140-50-3003	70120113T	30	3500	230/460	66.9/33.5	248	200	524
HMV140-60-2-3003	70120113G	30	3500	230/460	66.9/33.5	248	200	606
HMV140-60-4003	70120113V	40	3500	230/460	90.7/45.4	248	200	629
HMV140-70-2-4003	70120113X	40	3500	230/460	90.7/45.4	248	200	704
HMV140-70-4003	70120113H	40	3500	230/460	90.7/45.4	248	200	731
HMV140-80-5003	70120113Z	50	3500	230/460	111/55.7	248	200	806
HMV140-90-2-5003	70120113I	50	3500	230/460	111/55.7	248	200	895
HMV140-90-5003	70120113Z2	50	3500	230/460	111/55.7	248	200	921
HMV140-100-2-6003	70120113Z4	60	3500	230/460	134/66.8	248	200	1016
HMV140-100-6003	70120113J	60	3500	230/460	134/66.8	248	200	1032
HMV200-10-1-1003	70120115A	10	3500	230/460	18.3/9.1	248	292	124
HMV200-10-1003	70120115B	10	3500	230/460	24.7/12.3	248	292	131
HMV200-20-2003	70120115C	20	3500	230/460	46/23	248	292	255
HMV200-30-2-2503	70120115D	25	3500	230/460	56.5/28.2	248	292	387
HMV200-30-3003	70120115E	30	3500	230/460	66.9/33.5	248	292	390
HMV200-40-4003	70120115F	40	3500	230/460	90.7/45.4	248	292	511
HMV200-50-5003	70120115G	50	3500	230/460	111/55.7	248	292	508
HMV200-70-2-6003	70120115H	60	3500	230/460	134/66.8	248	292	878
HMV200-80-2-7503	70120115I	75	3500	230/460	163/81.3	248	292	1009
HMV300-10-1-1503	70120117A	15	3500	230/460	34/17	248	410	131
HMV300-10-2003	70120117B	20	3500	230/460	46/23	248	410	157
HMV300-20-2-3003	70120117C	30	3500	230/460	66.9/33.5	248	410	265
HMV300-20-4003	70120117H	40	3500	230/460	90.7/45.4	248	410	298
HMV300-30-2-4003	70120117D	40	3500	230/460	90.7/45.4	248	410	409
HMV300-30-5003	70120117E	50	3500	230/460	111/55.7	248	410	454
HMV300-40-2-6003	70120117F	60	3500	230/460	134/66.8	248	410	573
HMV300-40-7503	70120117J	75	3500	230/460	163/81.3	248	410	605
HMV300-50-2-7503	70120117G	75	3500	230/460	163/81.3	248	410	720

**Barmesa Pumps USA**  
844-BARMESA (227-6372)

**Sales Office**

Marion Ave. Mansfield, OH 44903 USA  
419-566-3318

**Warehouse**

103 Flecha Lane Laredo, TX 78045 USA  
956-608-3119

© Barmesa Pumps LLC. All rights reserved.

Product details shown here are subject to change without notice.