

SUBMERSIBLE NON-CLOG SEWAGE PUMP

Series: 4BSE-SS
3 & 5 HP / 1750 RPM
Discharge: 4"
Spherical solids handling: 3"



DISCHARGE

4", 125 lb, flange horizontal.

LIQUID TEMPERATURE

104°F (40°C) continuous.

VOLUTE

Cast iron ASTM A-48 class 30.

MOTOR HOUSING

Cast iron ASTM A-48 class 30.

SEAL PLATE

Cast iron ASTM A-48 class 30.

IMPELLER

Design: 2 vane, open, with vanes on back side.

Material: cast iron ASTM A-48 class 30.

SHAFT

416 series stainless steel.

HARDWARE

300 stainless steel.

SQUARE RINGS

Buna-N.

PAINT

Air dry enamel, water based.

SEAL

Design: inboard, single mechanical, oil filled chamber.

Material: silicon carbide, with stainless steel hardware.

CORD ENTRY

25 ft of neoprene cord SO 10/4, sealed against moisture.

BEARINGS

Upper: ball, single row, oil lubricated, for radial load.

Lower: ball, single row, oil lubricated, for radial and thrust load.

MOTOR

Single phase: NEMA L, permanent split capacitor, 230 volts, 60 Hz, 1750 RPM, oil filled, overload protection in motor.

Three phase: NEMA B, 200/230 & 460 volts, 60 Hz, 1750 RPM, oil filled. Requires overload protection to be included in control panel.

OPTIONAL EQUIPMENT

Additional cord, slide rail coupling (SRC-4).



SPECIFICATIONS

Submersible Non-Clog Sewage Pump Series: **4BSE-SS**

General:

Furnish and install a quantity of ____ Barmesa® Pumps submersible sewage pump(s), Model 4BSE____SS, ____ HP, ____ RPM, ____ phase, 60 Hz, ____ volts, with a 4 inch horizontal discharge 125 ANSI discharge flange connection. Each pump shall be capable of delivering the following performance, ____ US GPM at ____ ft total dynamic head, with a shut off head of ____ ft TDH minimum, and ____ % efficiency at ____ US GPM at ____ ft TDH operating point.

Pump Design:

The centrifugal sewage/non-clog pump(s) shall be capable of handling 3 inch diameter spherical solids of raw, unscreened domestic sewage consisting of water, fibrous materials. The pump(s) shall be capable of handling liquids with temperatures to 104 °F continuous, and shall be capable of running dry for extended periods.

Pump Construction:

Castings: The volute, seal plates, impeller and motor housing shall be constructed of ASTM A-48 class 30 cast iron.

Coating/Hardware: Exterior surfaces shall be painted with a water based air dry enamel. All exposed hardware shall be 300 series stainless steel.

Gaskets: All gaskets shall be of the compression square ring type eliminating critical slip fits and the possibility of damage during service associated with sliding o-ring sealing arrangements.

Impeller: The impeller shall be of 2 vane, open type, non-clog design with pump out vanes on the back side. Impellers shall be capable of being trimmed to meet specific performance characteristics. The impeller shall be dynamically balanced to ISO G6.3 specifications.

Mechanical seal: A dual seal arrangement shall consist of a Buna-N exclusion seal and a single mechanical design operating in an oil-filled seal cavity. The seal shall be constructed of Silicon carbide faces, 300 series stainless steel hardware, and all elastomer parts to be of Buna-N. The seal shall be commercially available and not a manufacturers proprietary design.

Motor: Design shall be of the split capacitor design for single phase units. The pump shall be designed to be non-overloading throughout the entire pump curve. The rotor and stator assembly shall be of the standard frame design and secured to the pump seal plate by four threaded fasteners allowing for easy serviceability.

The motor windings shall be of Class B insulation and operate in a sealed environment containing clean dielectric oil, making it capable of operating in a totally, partially or non-submerged condition for extended periods of time without damage due to the heat being generated. The used dielectric oil must be disposed of as non-hazardous waste. The motor shall meet the standard NEMA L for single phase and NEMA B for three phase.

Thermal Protection: All single phase motors shall have thermal protection with automatic reset. Three phase motors shall be equipped with a thermal switch embedded in the stator windings and require external overload protection in the control panel.

Shaft: The pump shaft shall be of a one-piece design and shall be of 416 stainless steel.

Bearings: The lower bearing shall be of the single row ball type to accept radial and thrust loads, and the upper bearing of the single ball type for radial loads. Bearings shall operate in an oil bath atmosphere for superior life.

Power Cord: All pump(s) shall be equipped with ____ ft of type SOW cord. The cord shall enter a cast iron terminal box assembly that is bolted to the motor housing and sealed with a Buna-N o-ring. The incoming lead wires shall be spliced in the terminal box. After splicing, the terminal box shall be filled with epoxy to seal the outer cable jacket and the individual strands to prevent water from entering the motor housing. The outer cord shall have an epoxy filled heat shrink tube to prevent water from entering the motor housing. Terminal connectors shall connect the incoming lead wires with the motor lead wires. Additional sealing and strain relief shall utilize a secondary pressure grommet at point of cable entry.

Tests and inspections: Shall be performed by the pump manufacture.

1. A ground continuity check and motor chamber shall be Hi-potted to test for electrical integrity.
2. Check that motor voltage and frequency matches name plate.
3. The pump shall be pressurized and a air leak test is performed to ensure the integrity of the motor housing.
4. The pump is submerged and operated to determine the unit meets hydraulic performance requirements.

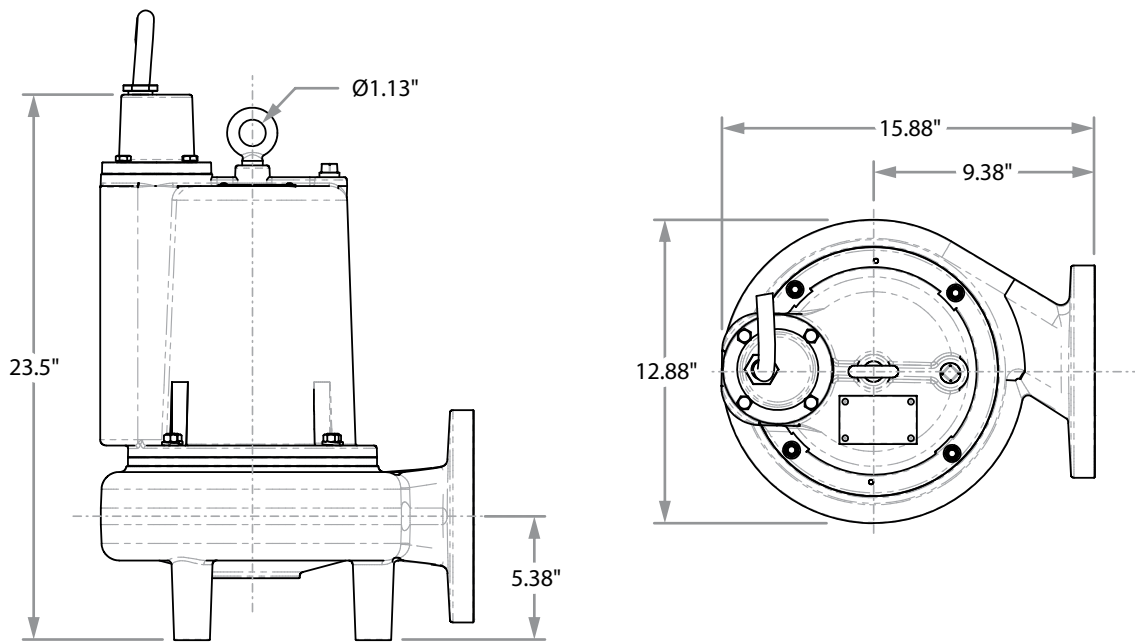

MODEL	PART No.	HP	VOLTS	PHASE	RPM (Nominal)	MAX AMPS	LOCKED ROTOR AMPS	NEMA CODE	CORD SIZE	CORD TYPE	CORD O.D.	WEIGHT (pounds)
4BSE302SS	62170101	3	230	1	1750	12.6	23	D	10/4	SO	0.75"	201
4BSE303SS	62170102	3	200/230	3	1750	15	44	D	10/4	SO	0.75"	201
4BSE304SS	62170103	3	460	3	1750	7.5	22	D	10/4	SO	0.75"	201
4BSE502SS	62170104	5	230	1	1750	28	56	D	10/4	SO	0.75"	201
4BSE503SS	62170105	5	200/230	3	1750	19	56	D	10/4	SO	0.75"	201
4BSE504SS	62170106	5	460	3	1750	9.5	28	D	10/4	SO	0.75"	201

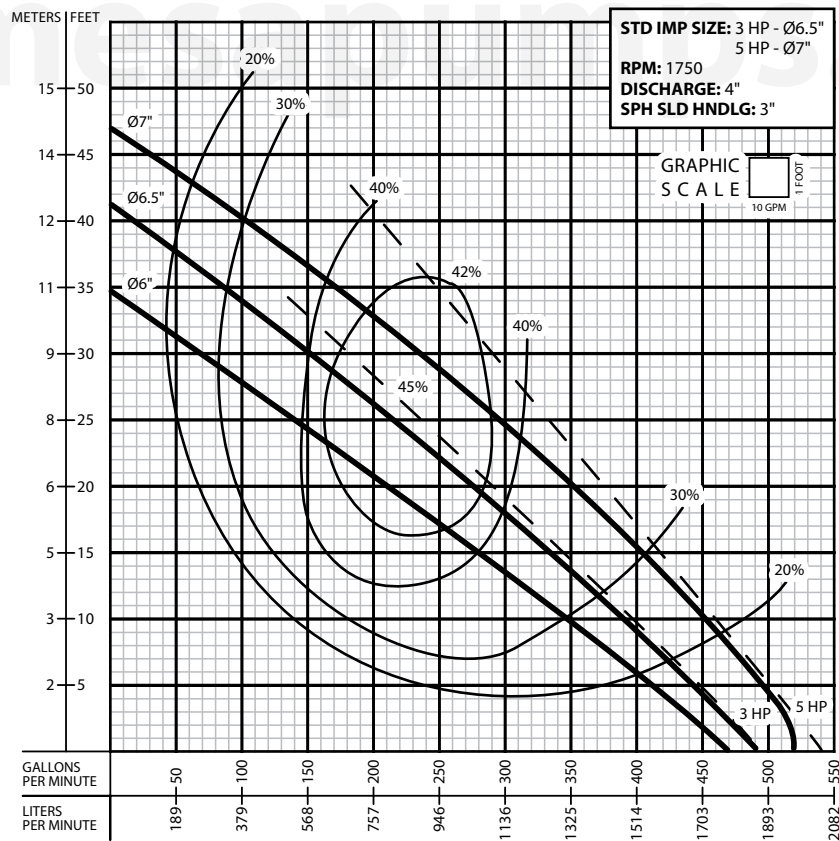

IMPORTANT!

1. Never use this pump to handle explosive liquids.
2. This pump is not approved to be used in swimming pools, recreational installations or any application where human contact may be common.
3. Pump may be operated "dry" for extended periods without damage to motor &/or seals.
4. Testing is performed with water specific gravity of 1.0 @ 68 °F (20 °C); other fluids may vary performance.