

SUBMERSIBLE NON-CLOG SEWAGE PUMP

Series: 3BSE-SS
1.5 & 2 HP / 1750 RPM
Discharge: 3"
Spherical solids handling: 2½"



DISCHARGE

3" NPT female, vertical, bolt on flange.

LIQUID TEMPERATURE

104°F (40°C).

VOLUTE

Cast iron ASTM A-48 class 30.

MOTOR HOUSING

Cast iron ASTM A-48 class 30.

SEAL PLATE

Cast iron ASTM A-48 class 30.

IMPELLER

Design: 2 vane, open, with vanes on back side.

Material: cast iron ASTM A-48 class 30.

SHAFT

416 series stainless steel.

HARDWARE

300 series stainless steel.

SQUARE RINGS

Buna-N.

PAINT

Air dry enamel, water based.

SEAL

Design: inboard, single mechanical, oil filled chamber.

Material: silicon carbide, with stainless steel hardware.

CORD ENTRY

25 ft of neoprene cord SJO 14/3, sealed against moisture.

BEARINGS

Upper: ball, single row, oil lubricated, for radial load.

Lower: ball, single row, oil lubricated, for radial and thrust load.

MOTOR

Single phase: NEMA L, permanent split capacitor, 200/230 volts, 60 Hz, 1750 RPM, oil filled, with overload protection in motor.

Three phase: NEMA B, 200/230 & 460 volts, 60 Hz, 1750 RPM, oil filled. Requires overload protection to be included in control panel.

OPTIONAL EQUIPMENT

Additional cord.

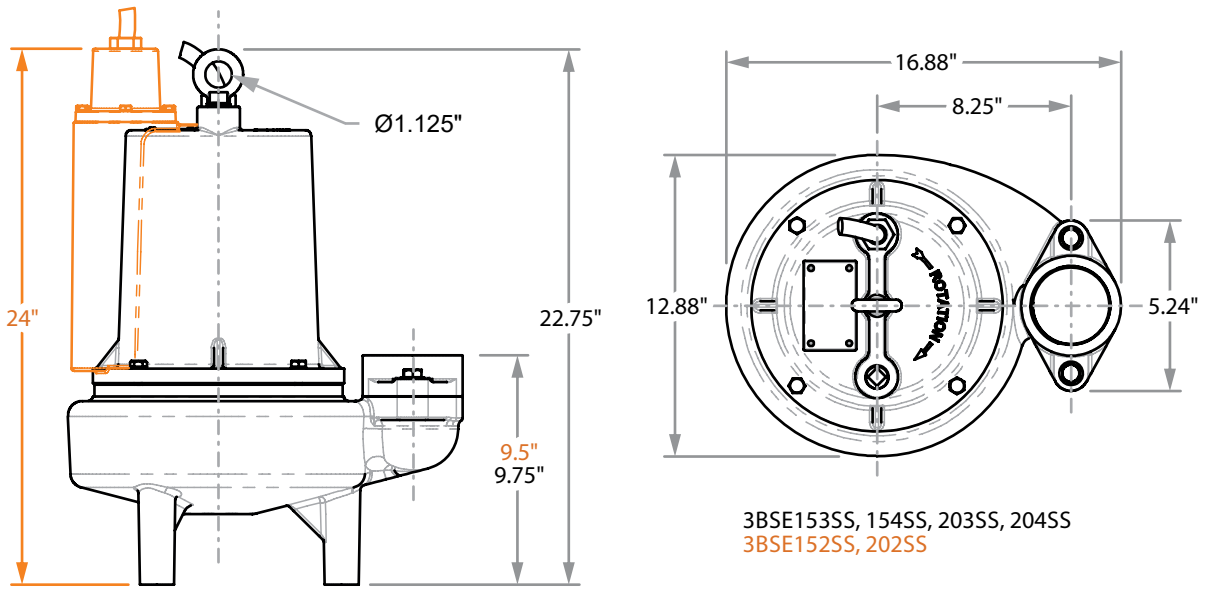

3BSE153SS, 154SS, 203SS, 204SS
3BSE152SS, 202SS

MODEL	PART No.	HP	VOLTS	PHASE	RPM (Nominal)	MAX AMPS	LOCKED ROTOR AMPS	NEMA CODE	CORD SIZE	CORD TYPE	CORD O. D.	WEIGHT (pounds)
3BSE152SS	62170010	1.5	200/230	1	1750	12.6	23	B	10/3	SJO	0.69"	146
3BSE153SS	62170011		200/230	3		11.6	36	H/L	10/4		0.75"	
3BSE154SS	62170012		460	3		5.8	17.5	L	10/4		0.75"	
3BSE202SS	62170013	2	200/230	1	1750	14.5	29	B	10/3	SJO	0.69"	146
3BSE203SS	62170014		200/230	3		14	50.8	J/M	10/4		0.75"	
3BSE204SS	62170015		460	3		7	25.4	M	10/4		0.75"	

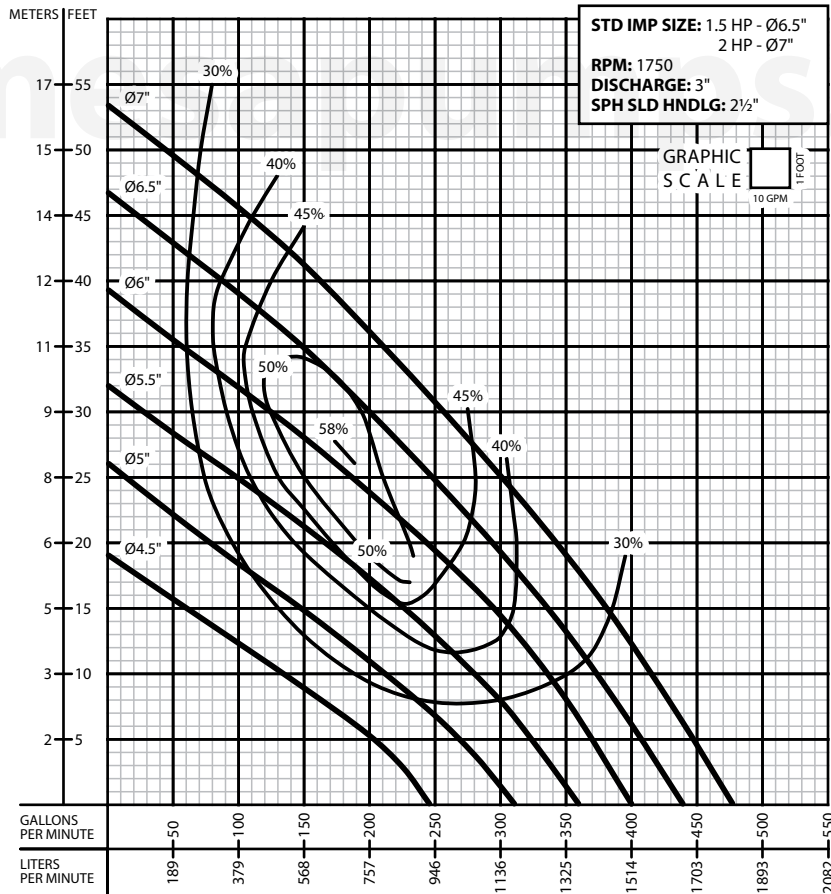

IMPORTANT!

1. Never use this pump to handle explosive liquids.
2. This pump is not approved to be used in swimming pools, recreational installations or any application where human contact may be common.
3. Pump may be operated "dry" for extended periods without damage to motor &/or seals.
4. Testing is performed with water specific gravity of 1.0 @ 68 °F (20 °C); other fluids may vary performance.