

SUBMERSIBLE NON-CLOG SEWAGE PUMP

Series: 8BSE-HLDS
36-48 HP / 1150 RPM
Discharge: 8"
Spherical solids handling: 3"



DISCHARGE

8", 125 lb, flange horizontal.

LIQUID TEMPERATURE

104°F (40°C).

VOLUTE

Cast iron ASTM A-48 class 30.

MOTOR HOUSING

Cast iron ASTM A-48 class 30.

SEAL PLATE

Cast iron ASTM A-48 class 30.

IMPELLER

Design: 3 vanes, closed, with a bronze wear ring and vanes on back side.

Material: cast iron ASTM A-48 class 30.

SHAFT

416 series stainless steel.

SQUARE RINGS

Square shaped Buna-N.

PAINT

Air dry enamel, water based.

DIAPHRAGM

Buna-N.

HARDWARE

300 series stainless steel.

SEAL

Design: double, mechanical, oil filled chamber.

Material: silicon carbide outboard seal, carbon ceramic inboard seal, Buna-N elastomer and stainless steel hardware.

CORD ENTRY

25 ft of neoprene cord, sealed against moisture.

BEARINGS

Upper: ball, single row, oil lubricated, for radial load.

Lower: ball, single row, oil lubricated, for radial and thrust load.

MOTOR

NEMA B, three phase, 230 & 460 volts, 60 Hz, 1150 RPM, oil filled. Requires overload protection to be included in control panel.

MOISTURE SENSOR

Normally open (N/O) included.

TEMPERATURE SENSOR

Normally closed (N/C) included.

OPTIONAL EQUIPMENT

Impeller trimming, additional cord, tungsten carbide seal, slide rail coupling (SRC-8).

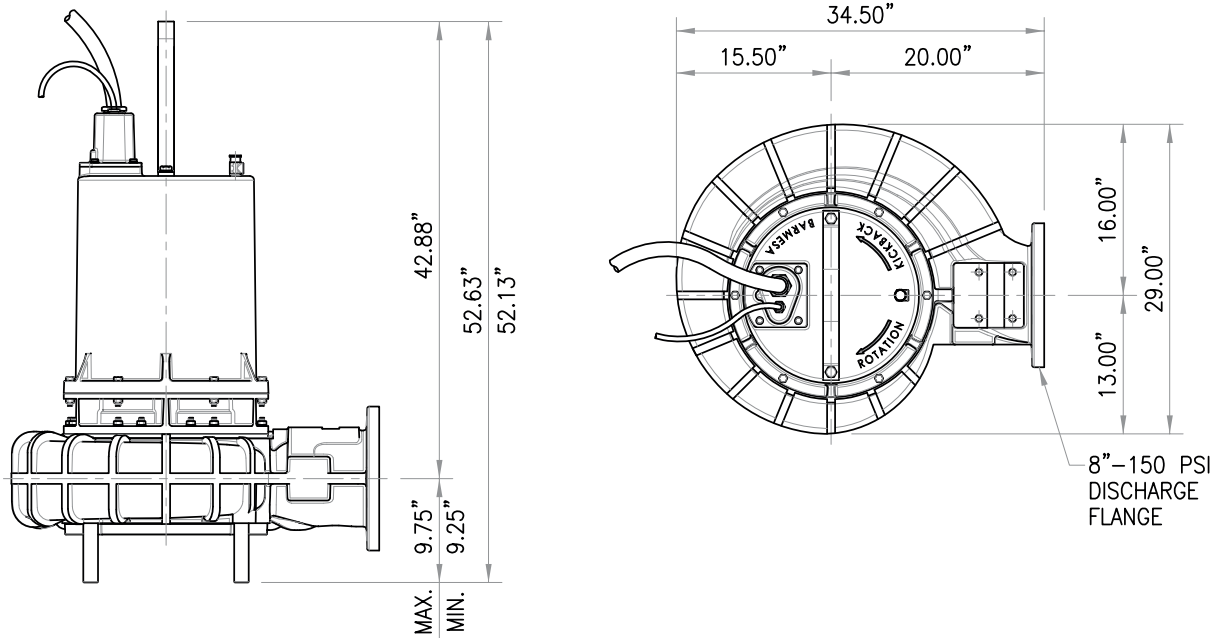

MODEL	PART No.	HP	VOLTS	PHASE	RPM (Nominal)	MAX AMPS	LOCKED ROTOR AMPS	NEMA CODE	CORD SIZE	CORD TYPE	CORD O. D.	WEIGHT (pounds)
8BSE36036HLDS	62170351	36	230	3	1150	90	434	E	2/3	3G	1.34"	928
8BSE36046HLDS	62170352	36	460	3	1150	45	217	E	2/3	3G	1.34"	928
8BSE48046HLDS	62170353	48	460	3	1150	65	290	E	2/3	3G	1.34"	986

The moisture cord and/or temperature cord is size 18/5, type SO, Ø0.485", for all models.

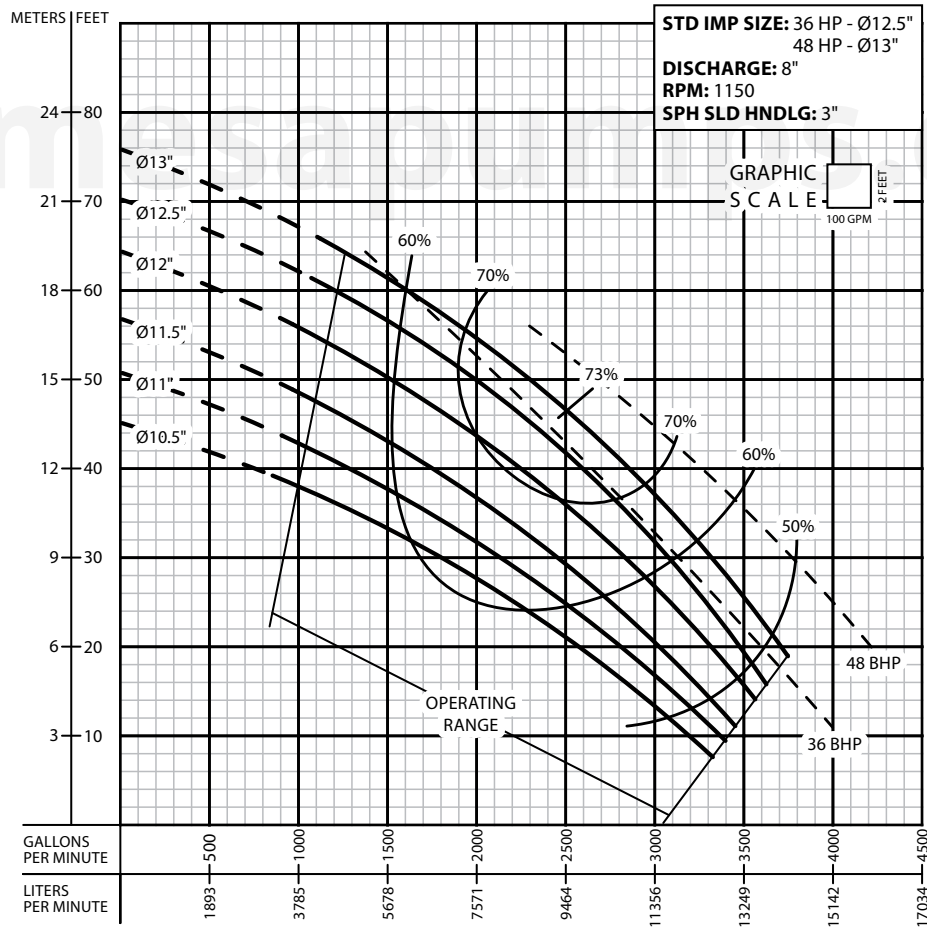

IMPORTANT!

1. Never use this pump to handle explosive liquids.
2. This pump is not approved to be used in swimming pools, recreational installations or any application where human contact may be common.
3. Pump may be operated "dry" for extended periods without damage to motor &/or seals.
4. Testing is performed with water specific gravity of 1.0 @ 68 °F (20 °C); other fluids may vary performance.