

4BWSE-DS

2 - 7.5 HP
@ 1750 RPM



IMPORTANT! - Read all instructions in this manual before operating or servicing a pump.

Before installation, read the following instructions carefully. Failure to follow instruction and safety information could cause serious bodily injury, death and/or property damage. Each Barmesa product is carefully inspected to insure proper performance. Closely following these instructions will eliminate potential operating problems, assuring years of trouble-free service.

⚠ DANGER "Danger" indicates an imminently hazardous situation which, if not avoided, WILL result in death or serious injury.

⚠ WARNING "Warning" indicates an imminently hazardous situation which, if not avoided, MAY result in death or serious injury.

⚠ CAUTION "Caution" indicates a potentially hazardous situation which, if not avoided, MAY result in minor or moderate injury.

IMPORTANT! - Barmesa Pumps is not responsible for losses, injury or death resulting from failure to observe these safety precautions, misuse, abuse or misapplication of pumps or equipment.

 **ALL RETURNED PRODUCTS MUST BE CLEANED, SANITIZED, OR DECONTAMINATED PRIOR TO SHIPMENT, TO INSURE EMPLOYEES WILL NOT BE EXPOSED TO HEALTH HAZARDS IN HANDLING SAID MATERIAL. ALL APPLICABLE LAWS AND REGULATIONS SHALL APPLY.**

⚠ WARNING Installation, wiring, and junction connections must be in accordance with the National Electric Code and all applicable state and local codes. Requirements may vary depending on usage and location.

⚠ WARNING Installation and servicing is to be conducted by qualified personnel only.

 Keep clear of suction and discharge openings. Do not insert fingers in pump with power connected; the rotating cutter and/or impeller can cause serious injury.

 Always wear eye protection when working on pumps. Do not wear loose clothing that may become entangled in moving parts.

⚠ DANGER Pumps build up heat and pressure during operation. Allow time for pumps to cool before handling or servicing the pump or any accessory items associated with or near the pump.

⚠ DANGER This pump is not intended for use in swimming pools or water installations where there is human contact with pumped fluid.

⚠ DANGER Risk of electric shock. To reduce risk of electric shock, always disconnect pump from power source before handling any aspect of the pumping system. **Lock out power and tag.**

⚠ WARNING Do not use these pumps in water over 104° F. Do not exceed manufacturers recommended maximum performance, as this could cause the motor to overheat.

⚠ DANGER Do not lift, carry or hang pump by the electrical cables. Damage to the electrical cables can cause shock, burns or death. **Never** handle connected power cords with wet hands. Use appropriate lifting device.

⚠ WARNING Ground Fault Circuit Interrupter (GFCI) to be used with plug-in type power cord.

⚠ WARNING Sump and sewage pumps often handle materials which could cause illness or disease. Wear adequate protective clothing when working on a used pump or piping. Never enter a basin after it has been used.

⚠ DANGER Failure to permanently ground the pump, motor and controls before connecting to power can cause shock, burns or death.

⚠ DANGER These pumps are not to be installed in locations classified as hazardous in accordance with the National Electric Code, ANSI/NFPA 70.

⚠ WARNING The Uniform Plumbing Code (UPC) states that sewage systems shall have an audio and visual alarm that signals a malfunction of the systems, that are required to reduce the potential for property damage.

IMPORTANT! - Prior to installation, record Model Number, Serial, Amps, Voltage, Phase and HP from pump name plate for the future reference. Also record the Voltage and Current Readings at Startup:

Model Number: _____

Serial: _____

Phase: _____ HP: _____

- DISCHARGE:** 4", 125lb, flange horizontal.
- SPHERICAL SLD HNDLG:** 3"
- LIQUID TEMPERATURE:** 104° F (40° C) continuous, 140° F (60° C) intermittent operation.
- VOLUTE:** Cast iron ASTM A-48 class 30.
- MOTOR HOUSING:** Cast iron ASTM A-48 class 30.
- SEAL PLATE:** Cast iron ASTM A-48 class 30.
- IMPELLER:** 2 vane, semi-open, with vanes on back side. Cast iron ASTM A-48 class 30.
- SHAFT:** 416 series stainless steel.
- SQUARE RINGS:** Buna-N.
- PAINT:** Air dry enamel, water based.
- SEAL:** Double, mechanical, oil filled chamber. Silicon carbide with Viton® type O1 outboard, carbon ceramic with Buna-N inboard seal, with stainless steel hardware.
- HARDWARE:** 300 series stainless steel.
- CORD ENTRY:** 40 ft of cord, epoxy sealed housing with secondary pressure gromet for sealing and strain relief.
- MOTOR:** Three phase, NEMA B, oil filled. Requires overload protection to be included in control panel. Class F insulation.
- OPTIONAL EQUIPMENT:** Additional cord, tungsten carbide seal, slide rail coupling (SRC-4).

MODEL	PART No.	HP	VOLTS	PHASE	RPM (Nominal)	MAX AMPS	LOCKED ROTOR AMPS	NEMA CODE	CORD SIZE	CORD TYPE	WEIGHT (pounds)
4BWSE203DS	62170151	2	230	3	1750	11.6	40	F	14/4	STOW	200
4BWSE204DS	62170152	2	460	3	1750	5.8	20	F	14/4	STOW	200
4BWSE303DS	62170153	3	230	3	1750	14.4	49.5	H	14/4	STOW	205
4BWSE304DS	62170154	3	460	3	1750	7.2	24.8	H	14/4	STOW	205
4BWSE503DS	62170155	5	230	3	1750	16.6	63.6	E	14/4	STOW	210
4BWSE504DS	62170156	5	460	3	1750	8.3	31.8	E	14/4	STOW	210
4BWSE753DS	62170157	7.5	230	3	1750	23	105	G	10/4	STOW	225
4BWSE754DS	62170158	7.5	460	3	1750	11.5	52.5	G	10/4	STOW	225

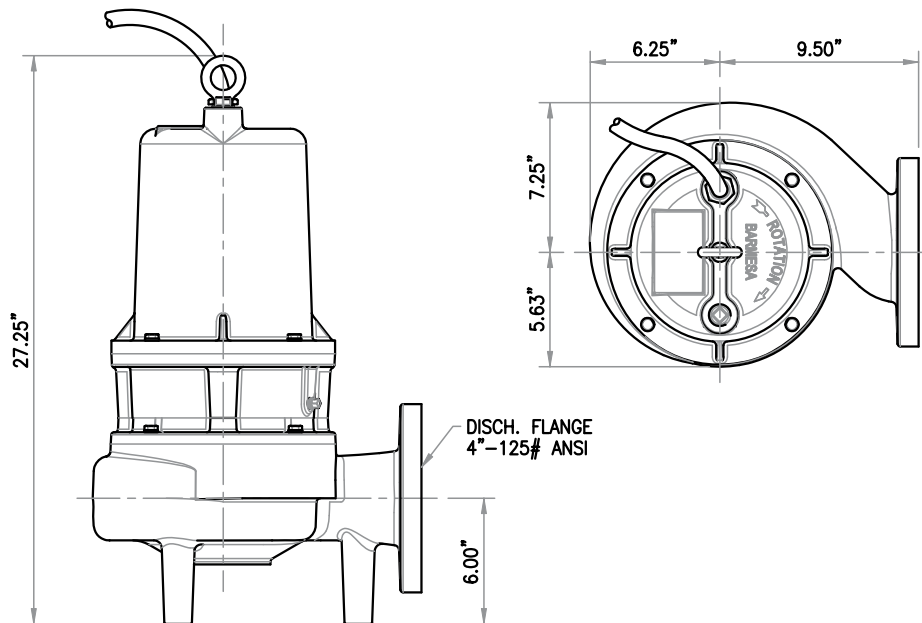

► Receiving inspection

Open all cartons and inspect for shipping damage. Report any damage to your supplier or shipping carrier immediately.

Important: Always verify that the pump nameplate Amps, Voltage, Phase and HP ratings match your control panel and power supply.

Many of our sewage pumps are oil-filled. If there are any signs of oil leakage or if the unit has been stored for an extended period, check the oil level in the motor dome and the seal housing, if so equipped.

Check the motor cover oil level through the pipe plug on top of the unit. The motor chamber oil should just cover the motor. Do not overfill, leave room for expansion!

To check the seal housing oil level, where used, lay the unit on its side with the fill plug at 12 o'clock. Remove the plug. The oil should be within 1/2" (13mm) of the top. If low, refill with an ASTM 150 turbine oil. Replace the plug.

You can source oil locally at motor repair shops. Typical oil brands are: Shell Turbo 32, Sunoco Sunvis 932, Texaco Regal R&O 32, Exxon Nuto 32 and Mobil DTE Light.

Check the strain relief nut on power cable strain assemblies. Power cables should be torqued to 75 in/lbs. for #16 cables and 80 in/lbs. for all other cable assemblies. Seal/heat sensor cables, where used, should be torqued to 75 in/lbs.

Warranty does not cover damage caused by connecting pumps and controls to an incorrect power source (voltage/phase supply).

Record the model numbers and serial numbers from the pumps and control panel on the front of this instruction manual for future reference. Give it to the owner or affix it to the control panel when finished with the installation.

► Optional Guide Rail

In many effluent and sewage basins or lift stations it is advisable to install the pump on a guide rail system or on a lift-out adapter to facilitate installation and removal for inspection and/or service. Most codes do not allow personnel to enter a wetwell without the correct protective equipment and training. Guide rails are designed to allow easy removal of the pump without the need for entry into the wetwell or need to disturb piping. The guide rail or liftout adapter should locate the pump opposite the influent opening preventing stagnate areas where solids can settle. The basin or pit must be capable of supporting the weight of the pump and guide rail. The pit floor must be flat.

► Piping

Discharge piping should be no smaller than the pump discharge diameter and kept as short as possible, avoiding unnecessary fittings to minimize friction losses.

Install an adequately sized check valve matched to the solids handling capability of the pump to prevent fluid backflow. Backflow can allow the pump to spin backwards and may cause premature seal, bearing, shaft wear. If the pump is turning backwards when it is called on to start the increased torque may cause damage to the pump motor and/or motor shaft.

Install an adequately sized gate valve AFTER the check valve for pump, plumbing and check valve maintenance.

Important - Before pump installation. Drill a 3/16" (4.8mm) relief hole in the discharge pipe. It should be located within the wetwell, 2" (51mm) above the pump discharge but below the check valve. The relief hole allows any air to escape from the casing.

Allowing liquid into the casing will insure that the pump can start when the liquid level rises. Unless a relief hole is provided, a bottom intake pump could "air lock" and will not pump water even though the impeller turns.

All piping must be adequately supported, so as not to impart any piping strain or loads on the pump.

The pit access cover must be of sufficient size to allow for inspection, maintenance and crane or hoist service.

► Float Switch Types

There are two basic float switch designs; single-action and wide-angle. Single-action switches operate over a range of 15° so they open and close quickly. Wide-angle floats operate over a 90° swing with the tether length between the float body and the pivot point controlling the On-Off range. The design determines how many floats are required with different systems or controls. Floats may be normally open (NO) for pump down applications or to empty a tank. Normally closed (NC) switches are used to pump up or to fill a tank. A single-action control switch may be used only with a control panel, never direct connected to a pump. The wide-angle, pump down switches may be used as direct connected pump switches or as control switches.

► Setting the float switches

There are no absolute rules for where to set the float switches, it varies from job to job.

Suggested Rules to Follow: All floats should be set below the Inlet pipe!

Off Float: Best: set so free hanging the water level is always above the top of the pump (motor dome). Next Best: set so the water level is not more than 6" below the top of the pump.

On Float: set so the volume of water between the On and Off floats allows pumps of 1.5 HP and under to operate for 1 minute minimum. 2 HP and larger pumps should run a minimum of 2 minutes. Basin technical brochure states the gallons of storage per inch of basin height.

Lag/Alarm Float(s): should be staggered above the Off and On floats. Try to use most of the available storage provided by the basin, save some space for reserve storage capacity. Exact reserve may be called out by local codes. See Diagrams and Charts in Float Switch Chart Section.

▶ Panel wiring diagrams

Our control panels are shipped with instructions and wiring diagrams. Use those instructions in conjunction with this IOM. Electrical installation should be performed only by qualified technicians. Any problem or questions pertaining to another brand control must be referred to that control supplier or manufacturer.

▶ Alarms

We recommend the installation of an alarm on all wastewater pump installations. Many standard control panels come equipped with alarm circuits. If a control panel is not used, a stand alone high liquid level alarm is available. The alarm alerts the owner of a high liquid level in the basin so they can contact the appropriate service personnel to investigate the situation.

▶ Three phase pumps

As a Minimum a Ø3 pump requires a 3 pole circuit breaker/fused circuit, an across the line magnetic starter rated for the pump HP, and ambient compensated Quick Trip Class 10 overloads.

▶ Control Panels

Control panels are available as Simplex (controls 1 pump) or Duplex (controls 2 pumps). Our standard Panels are available with many standard features and can be built with our most popular options. We also custom build panels which offer many more design options. Custom control panels are available in many different configurations. Custom panel quote requests may be forwarded to Customer Service through any authorized distributor.

Our duplex panels feature a solid-state printed circuit board design with standard high level alarm circuits. Other standard features are: an auxiliary dry alarm contact for signaling a remote alarm and float switch position indicator lights. Our Ø3 panels have built-in, adjustable, Class 10 overloads. The adjustable overloads on all our Ø3 panels mean less labor for the installer and no need to order specific overloads. Most panels are in stock for immediate delivery without options.

Always follow wiring schematic of the panel. Failure to wire the seal failure and heat sensor leads correctly may prevent the pump from running or cause nuisance tripping.

▶ Installation

Connect the pump(s) to the guide rail pump adapters or to the discharge piping. Slide rail bases should be anchored to the wetwell floor.

Complete all wiring per the control panel wiring diagrams and NEC, Canadian, state, provincial and/or local codes. This a good time to check for proper rotation of the motors/impellers.



DO NOT PLACE HANDS IN PUMP SUCTION WHILE CHECKING MOTOR ROTATION. TO DO SO WILL CAUSE SEVERE PERSONAL INJURY.

Always verify correct rotation. Correct rotation is indicated on the pump casing. Three phase motors are reversible. It is allowable to bump or jog the motor for a few seconds to check impeller rotation. It is easier to check rotation before installing the pump. Switch any two power leads to reverse rotation.

Lower the pump(s) into the wetwell and check to insure that the floats will operate freely and not contact the piping.

▶ Operation

Once the piping connections are made and checked you can run the pumps.

Control Panel Operation - Fill the wetwell with clear water. Use the pump H-O-A (Hand-Off-Automatic) switches in hand to test the pumps. If they operate well in hand proceed to test Automatic operation. If the pumps run but fail to pump, they are probably air locked, drill the relief holes per the instructions in the Piping Section.

Place Control Panel switch(es) in Automatic position and thoroughly test the operation of the ON, OFF, and Alarm floats by filling the wetwell with clear water.

Important: Failure to provide a Neutral from the power supply to a Ø1, 230 volt Control Panel will not allow the panel control circuit to operate. The Neutral is necessary to complete the 115 volt control circuit.

Check voltage and amperage and record the data on the front of this manual for future reference. Compare the amperage readings to the pump nameplate maximum amperage. If higher than nameplate amperage investigate cause.

Operating the pump off the curve, i.e. with too little head or with high or low voltage will increase amperage. The motor will operate properly with voltage not more than 10% above or below pump nameplate ratings.

Performance within this range will not necessarily be the same as the published performance at the exact rated nameplate frequency and voltage. Correct the problem before proceeding. Three phase unbalance is also a possible cause. See power unbalance and follow the instructions.

Reset the Alarm circuit, place pump switch(es) in the Automatic position and Control Switch in ON position. The system is now ready for automatic operation.

Explain the operation of the pumps, controls and alarms to the end user. Leave the paperwork with the owner or at the control panel if in a dry, secure location.

► Float Switch and Panel Chart

The purpose of this chart is to show the required switch quantities and the function of each switch in a typical wastewater system. The quantities required vary depending on the switch type, single-action or wide-angle. Switch quantities also vary by panel type: simplex with and without alarms, and duplex with alarms.

Simplex Panel using single-action switches:

SIMPLEX PANEL WITH ALARM		
SW1	BOTTOM	PUMP OFF
SW2	MIDDLE	PUMP ON
SW3	TOP	ALARM ON/OFF

SIMPLEX PANEL WITH NO ALARM		
SW1	BOTTOM	PUMP OFF
SW2	TOP	PUMP ON

Simplex Panel using wide-angle switches:

SIMPLEX PANEL WITH ALARM		
SW1	BOTTOM	PUMP ON/OFF
SW2	TOP	ALARM ON/OFF

SIMPLEX PANEL WITH NO ALARM		
SW1		PUMP ON/OFF

Duplex Panels using single-action switches:

THREE FLOAT PANEL WIRING		
SW1	BOTTOM	PUMPS OFF
SW2	MIDDLE	1st PUMP ON
SW3	TOP	2nd PUMP & ALARM ON

FOUR FLOAT PANEL WIRING		
SW1	BOTTOM	PUMPS OFF
SW2	2nd	1st PUMP ON
SW3	3rd	2nd PUMP ON
SW4	TOP	ALARM ON

Duplex Panels using wide-angle switches:

THREE FLOAT PANEL WIRING		
SW1	BOTTOM	1st PUMP ON/BOTH OFF
SW2	TOP	2nd PUMP & ALARM ON

FOUR FLOAT PANEL WIRING		
SW1	BOTTOM	1st PUMP ON/BOTH OFF
SW2	MIDDLE	2nd PUMP ON
SW3	TOP	ALARM ON

Simplex Panel

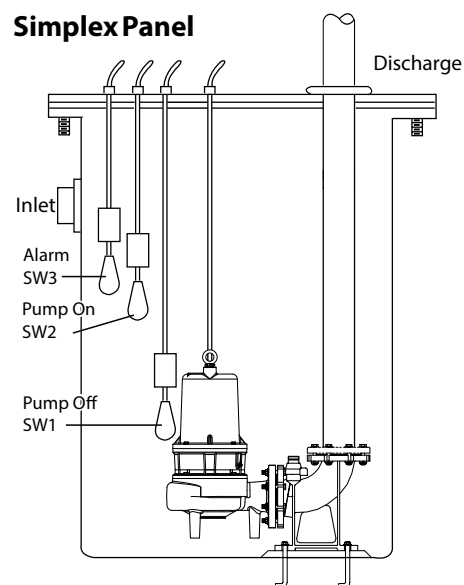

Duplex Panels

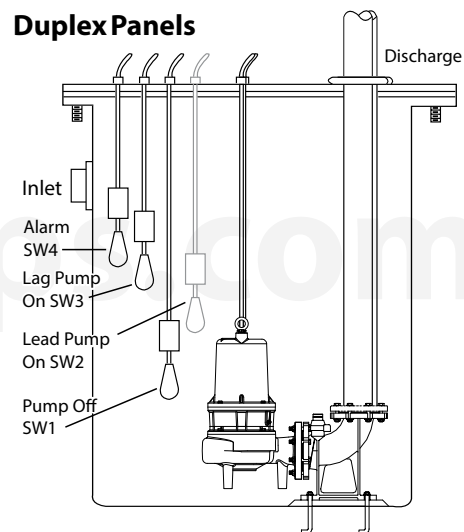

► Power Unbalance

A full three phase supply consisting of three individual transformers or one three phase transformer is recommended. "Open" delta or wye connections using only two transformers can be used, but are more likely to cause poor performance, overload tripping or early motor failure due to current unbalance. Check the current in each of the three motor leads and calculate the current unbalance as explained below. If the current unbalance is 2% or less, leave the leads as connected.

If the current unbalance is more than 2%, current readings should be checked on each leg using each of the three possible hook-ups. Roll the motor leads across the starter in the same direction to prevent motor reversal.

To calculate percent of current unbalance:

- A. Add the three line amp values together.
- B. Divide the sum by three, yielding average current.
- C. Pick the amp value which is furthest from the average current (either high or low).
- D. Determine the difference between this amp value (furthest from average) and the average.
- E. Divide the difference by the average. Multiply the result by 100 to determine percent of unbalance.

Current unbalance should not exceed 5% at service factor load or 10% at rated input load. If the unbalance cannot be corrected by rolling leads, the source of the unbalance must be located and corrected.

If, on the three possible hookups, the leg farthest from the average stays on the same power lead, most of the unbalance is coming from the power source. Contact your local power company to resolve the imbalance.

► Insulation Resistance Readings Normal Ohm and Megohm Values between all leads and ground (see table 1).

Insulation resistance varies very little with rating. Motors of all HP, voltage and phase ratings have similar values of insulation resistance.

Insulation resistance values above are based on readings taken with a megohmmeter with a 500V DC output. Readings may vary using a lower voltage ohmmeter, consult factory if readings are in question.

► Engineering Data

Engineering data for specific models may be found in your catalog. Control panel wiring diagrams are shipped with the control panels. Please use the control panel drawings in conjunction with this instruction manual to complete the wiring.

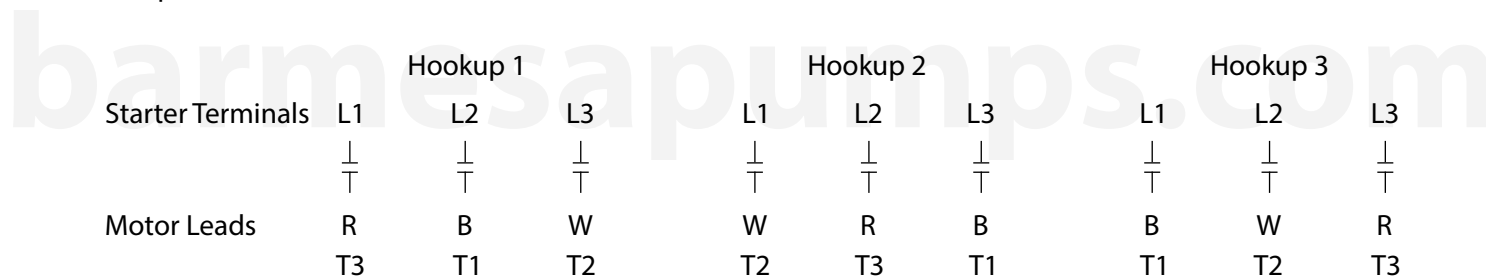

Example:

T3-R = 51 amps
 T1-B = 46 amps
 T2-W = 53 amps
 Total = 150 amps
 ÷ 3 = 50 amps
 - 46 = 4 amps
 4 ÷ 50 = .08 or 8%

T2-W = 50 amps
 T3-R = 48 amps
 T1-B = 52 amps
 Total = 150 amps
 ÷ 3 = 50 amps
 - 48 = 2 amps
 2 ÷ 50 = .04 or 4%

T1-B = 50 amps
 T2-W = 49 amps
 T3-R = 51 amps
 Total = 150 amps
 ÷ 3 = 50 amps
 - 49 = 1 amp
 1 ÷ 50 = .02 or 2%

Table 1

Condition of Motor and Leads	Ohm Value	Megohm Value
A new motor (without drop cable).	20,000,000 (or more)	20 (or more)
A used motor which can be reinstalled in well.	10,000,000 (or more)	10 (or more)
Motor in well. Readings are for drop cable plus motor.		
New motor.	2,000,000 (or more)	2 (or more)
Motor in good condition.	500,000 - 2,000,000	0.5 - 2
Insulation damage, locate and repair.	Less than 500,000	Less than 0.5

PUMP OPERATION			
Minimum Submergence		Maximum Fluid Temperature	
Continuous Duty	Fully Submerged	Continuous Operation	104 °F 40 °C
Intermittent Duty	6" Below Top of Motor	Intermittent Operation	140 °F 60 °C

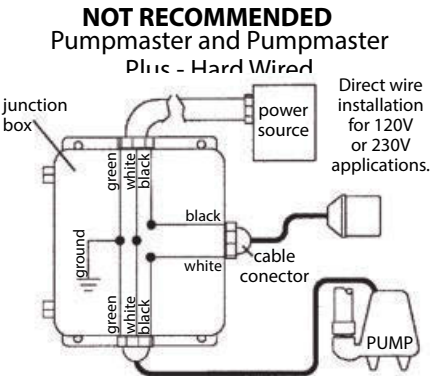
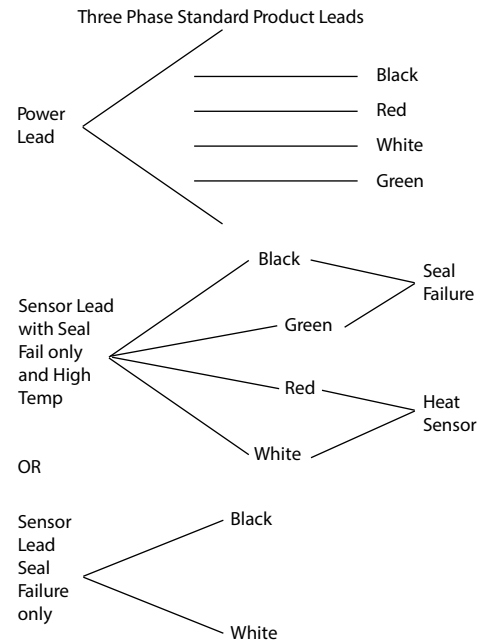

Figure 1

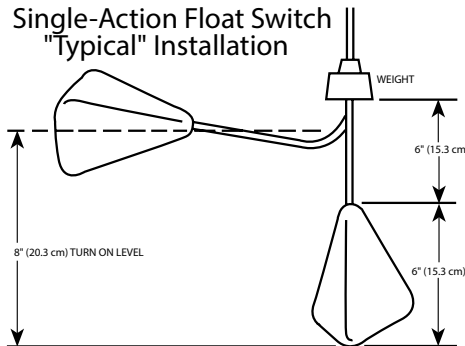

Figure 4

Figure 7

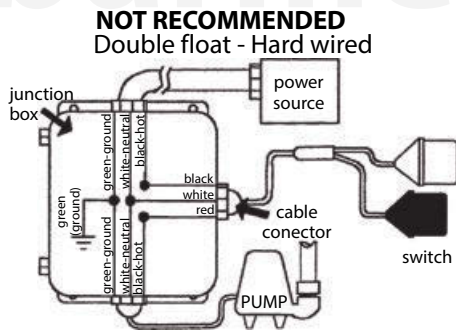

Figure 2

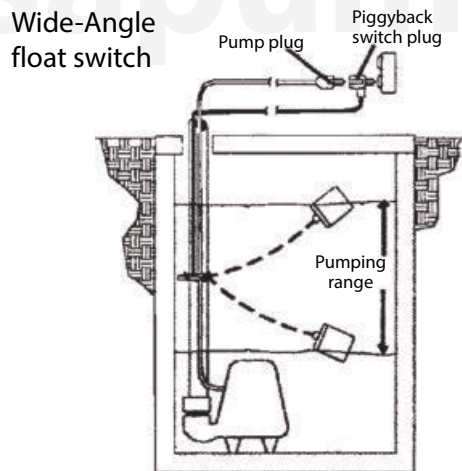

Figure 5

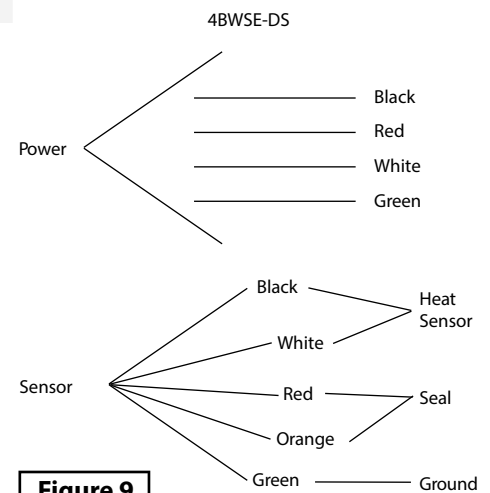

Figure 9

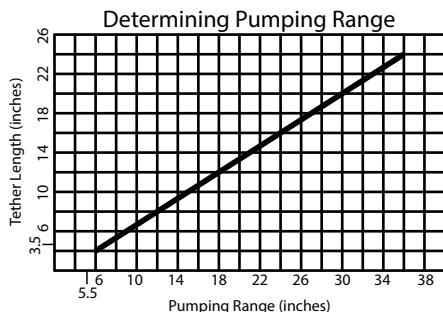

Figure 3

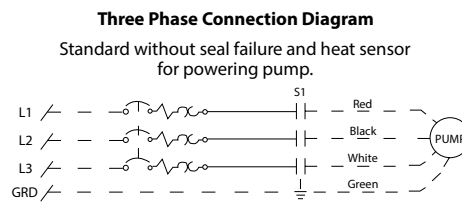
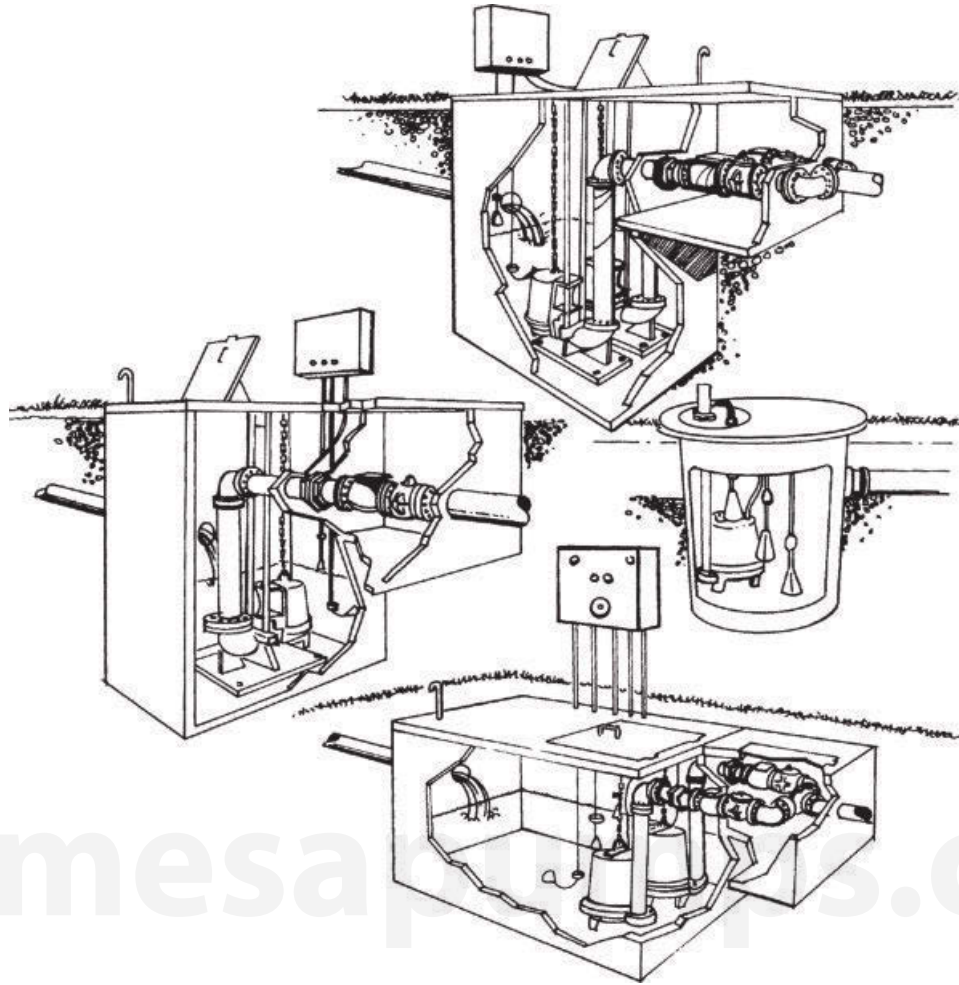
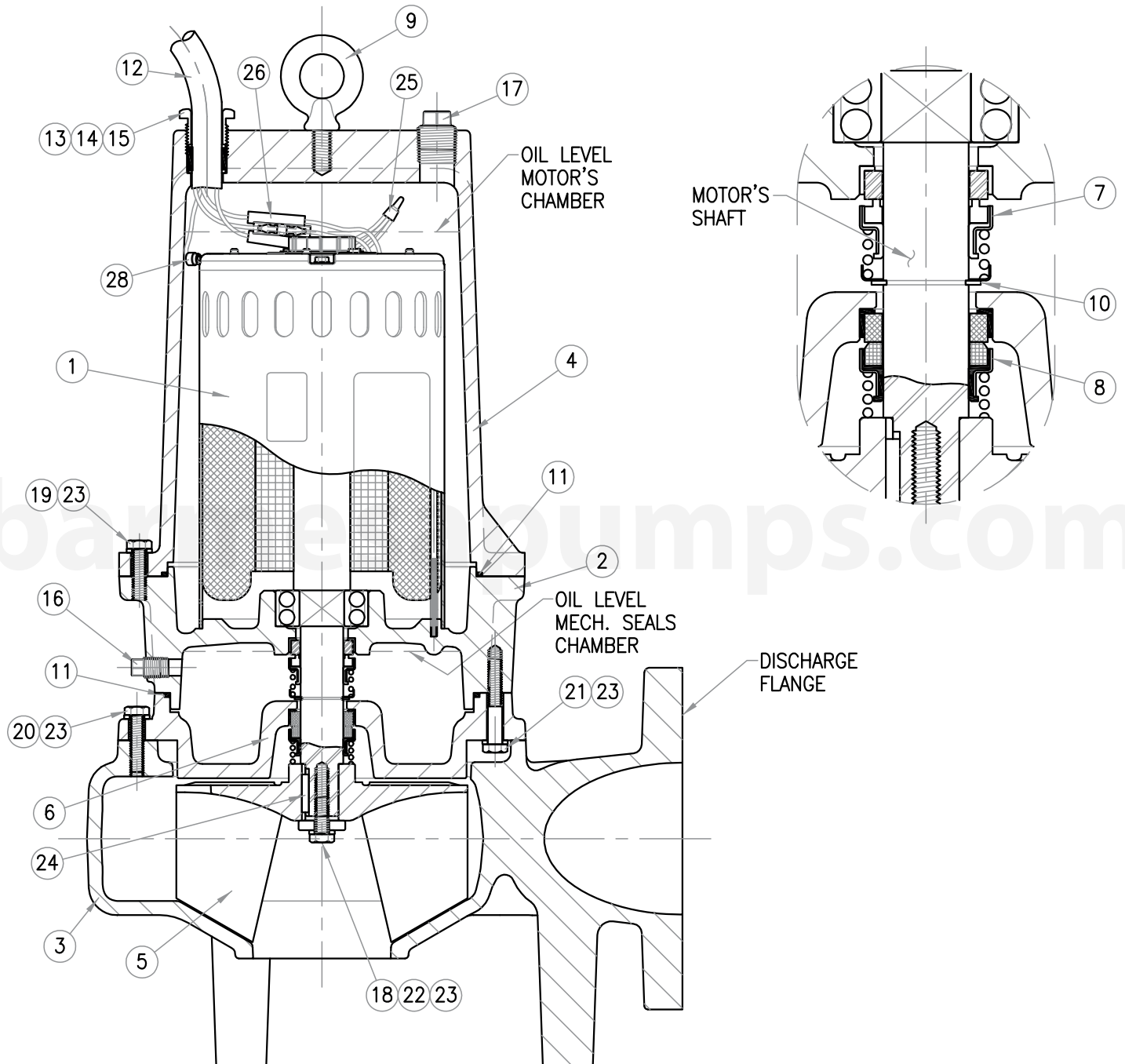

Figure 6

► Typical Installations



barmesa.com



For repair part please supply: Model Number and Serial as shown on Name Plate, and Part Description and Part Number as shown on Parts List.

ITEM	PART #	DESCRIPTION	QTY.
1		Electric motor	1
	40040068	7.5 HP, 3 ph, 230/460 V, frame 56Z	
	40040066	3 HP, 3 ph, 230/460 V, frame 56Z	
2	03040027	Bearing housing	1
3	03090095	Body	1
4	03100002	Motor housing	1
5		Impeller	1
	03140088	Diameter 7.690", for 7.5 HP	
	03140088B	Diameter 7.280", for 5 HP	
	03140088C	Diameter 7.000", for 3 HP	
	03140088D	Diameter 6.630", for 2 HP	
6	03180029	Seal plate	1
7	31030211	Mechanical seal Ø1 ¹ / ₈ " (Carbon/Ceramic/Buna/SS)	1
8	31030137	Mechanical seal Ø1 ¹ / ₈ " (Silicon/Silicon/Viton/SS)	1
9	91010406	Handle	1
10	31010017	Retaining ring # 5100-112	1
11	92010083	Gasket # 33730	2
12	31030003	Power cable 4 x10" (12.40 meters)	1
13	92010001	Grommet # 514	1
14	91010055	Washer # 54746	2
15	30400903	Hex head plug SE103-203-4SE	1
16	93010143	Pipe plug 1/4"	1
17	93010148	Pipe plug 3/4"	1
18	91010345C	Screw 3/8" x 1 ¹ / ₄ " SS	1
19	91010345C	Screw 3/8" x 1 ¹ / ₄ " SS	4
20	91010346	Screw 3/8" x 1 ¹ / ₂ " SS	4
21	91010347C	Screw 3/8" x 2 ¹ / ₄ " SS	4
22	30400426B	Impeller washer	1
23	91010061	Spring washer 3/8" SS	13
24	30400631	Keyway 3/16"x1-1/8"	1
25		Wire connector # 55044	1
	94010012	For 230 volts	
		For 460 volts	
26	94010027	Connector	3
27	94010041	Female terminal	6
28	94010043	Terminal	1
	31010031	DTE. Oil light	12 L
	99210007	Data plate	1
	99230102	Rivet SS # 001628	4

For repair part please supply: Model Number and Serial as shown on Name Plate, and Part Description and Part Number as shown on Parts List.



Risk of electric shock. Always disconnect the pump from the power source before handling inspections or repairs.

SYMPTOM	POSSIBLE CAUSE(s)	CORRECTIVE ACTION
<p>Motor not running. Note: If circuit breaker "OPENS" repeatedly, DO NOT reset. Call qualified electrician.</p> <p>Note: Check the pump in manual mode first to confirm operation. If pump operates, the automatic control or wiring is at fault. If pump does not operate, see above.</p>	Pump impeller binding or jammed.	Allow motor to cool. Insure minimum pump submergence. Clear debris from casing and impeller.
	Motor thermal protector tripped.	Determine cause, call a qualified electrician.
	Open circuit breaker or blown fuse.	Check motor amp draw. If two or more times higher than listed on pump nameplate, impeller is locked, motor bearings or shaft is damaged. Clear debris from casing and impeller, consult with dealer. Resistance between power leads and ground should read infinity. If any reading is incorrect, call a qualified electrician.
	Power cable is damaged.	Inspect control panel wiring. Call a qualified electrician.
	No neutral wire connected to control panel.	With switch disconnected, check continuity while activating liquid level switch. Replace switch, as required.
	Inadequate electrical connection in control panel.	Allow liquid level to rise 3" to 4" (76 mm - 101 mm) above turn-on level.
	Defective liquid level switch.	Untangle cords and insure free operation.
	Insufficient liquid level to activate controls.	Untangle cords and insure free operation.
<p>Pump will not turn off.</p>	Liquid level cords tangled.	Shut off pump for approximately one minute, then restart. Repeat until air lock clears. If air locking persists in a system with a check valve, a 3/16" (4.8 mm) hole may be drilled in the discharge pipe approximately 2" (51 mm) above the discharge connection.
	Pump is air locked.	Larger pump may be required.
	Influent flow is matching pump's discharge capacity.	Check flow arrow on valve and check valve operation.
<p>Little or no liquid delivered by pump.</p>	Check valve installed backwards, plugged or stuck closed.	Consult with dealer.
	Excessive system head.	Inspect and clear as required.
	Pump inlet plugged.	Check pump rotation, voltage and wiring. Consult with qualified electrician.
	Improper voltage or wired incorrectly.	See recommended action, above.
	Pump is air locked.	Inspect impeller, replace as required.
	Impeller is worn or damaged.	Inspect, readjust or replace as required.
	Liquid level controls defective or improperly positioned.	Inspect, repair or replace as required.
	Discharge check valve inoperative.	Consult with dealer.
<p>Little or no liquid delivered by pump.</p>	Sewage containment area too small.	Inspect, readjust or replace as required.
	Liquid level controls defective or improperly positioned.	Consult with dealer.
	Influent excessive for this size pump.	Inspect, readjust or replace as required.
		Consult with dealer.

NOTE: Barmesa Pumps assumes no responsibility for damage or injury due to disassembly in the field. Disassembly of the pumps or supplied accessories other than at Barmesa Pumps or its authorized service centers, automatically voids warranty.

BARMESA PUMPS FACTORY WARRANTY

Barmesa Pumps warrants that products of our manufacture will be free of defects in material and workmanship under normal use and service for 18 months from date of manufacture or 12 months from installation date whichever occurs first. This warranty gives you specific legal rights, which vary from state to state.

This warranty is a limited warranty, and no warranty related claims of any nature whatsoever shall be made against Barmesa Pumps, until the ultimate consumer or his/her successor notifies us in writing of the defect and delivers the product and/or defective part(s) freight prepaid to our factory or nearest authorized service station as instructed by Barmesa Pumps. THERE SHALL BE NO FURTHER LIABILITY, WHETHER BASED ON WARRANTY, NEGLIGENCE OR OTHERWISE. PRODUCT SHALL BE EITHER REPLACED OR REPAIRED AT THE ELECTION OF BARMESA PUMPS. Guarantees relating to performance specifications provided in addition to the foregoing material and workmanship warranties on a product manufactured by Barmesa Pumps, if any, are subject to possible factory testing. Any additional guarantees, in the nature of certified performance specifications or time frame must be in writing and such writing must be signed by our authorized factory manager at time of order placement and/or at time of quotation. Due to inaccuracies in field testing and should a conflict arises between the results of field testing conducted by or for the user, Barmesa Pumps reserves the right to have the product returned to our factory for additional testing.

This warranty shall not apply when damage is caused by (1) improper installation, (2) improper voltage, (3) lightning, (4) excessive sand or other abrasive material, (5) corrosion build-up due to excessive chemical content or (6) uncontrollable acts of god. Any modification of the original equipment will also void the warranty. We will not be responsible for loss, damage or labor cost due to interruption of service caused by defective pumps, parts or systems. Barmesa Pumps will not accept charges incurred by others without our prior written approval.

This warranty is void if our inspection reveals the product was used in a manner inconsistent with normal industry practice and/or our specific recommendations. The purchaser is responsible for communication of all necessary information regarding the application and use of the product. UNDER NO CIRCUMSTANCES WILL WE BE RESPONSIBLE FOR ANY OTHER DIRECT OR CONSEQUENTIAL DAMAGES, INCLUDING BUT NOT LIMITED TO TRAVEL EXPENSES, CONTRACTOR FEES, UNAUTHORIZED REPAIR SHOP EXPENSES, LOST PROFITS, LOST INCOME, LABOR CHARGES, DELAYS IN PRODUCTION, IDLE PRODUCTION, WHICH DAMAGES ARE CAUSED BY ANY DEFECTS IN MATERIAL AND/OR WORKMANSHIP AND/OR DAMAGE OR DELAYS IN SHIPMENT. THIS WARRANTY IS EXPRESSLY IN LIEU OF ANY OTHER EXPRESS OR IMPLIED WARRANTY. No rights extended under this warranty shall be assigned to any other person, whether by operation of law or otherwise, without our prior written approval.

IMPORTANT!

If you have a claim under the provision of the warranty, contact Barmesa Pumps or your authorized Barmesa Pumps Distributor:
warranty@barmesapumps.com
www.barmesapumps.com



