

# SUBMERSIBLE NON-CLOG SEWAGE PUMP

Series: 2BSE-SS  
0.5 & 0.75 HP / 1750 RPM  
Discharge: 2" or 3"  
Spherical solids handling: 2"



## DISCHARGE

2" or 3" NPT female, vertical, bolt on flange.

## LIQUID TEMPERATURE

104°F (40°C) continuous.

## VOLUTE

Cast iron ASTM A-48 class 30.

## MOTOR HOUSING

Cast iron ASTM A-48 class 30.

## SEAL PLATE

Cast iron ASTM A-48 class 30.

## IMPELLER

**Design:** 2 vane, open, with vanes on back side.

**Material:** cast iron ASTM A-48 class 30.

## SHAFT

416 series stainless steel.

## HARDWARE

300 series stainless steel.

## SQUARE RINGS

Buna-N.

## PAINT

Air dry enamel, water based.

## SEAL

**Design:** inboard single mechanical, oil filled chamber.

**Material:** silicon carbide, with stainless steel hardware.

## CORD ENTRY

20 ft of neoprene cord SJO 14/3, sealed against moisture.

## BEARINGS

**Upper:** ball, single row, oil lubricated, for radial load.

**Lower:** ball, single row, oil lubricated, for radial and thrust load.

## MOTOR

**Single phase:** NEMA L, permanent split capacitor, 115 & 230 volts, 60 Hz, 1750 RPM, oil filled, overload protection in motor.

**Three phase:** NEMA B, 200/230 & 460 volts, 60 Hz, 1750 RPM, oil filled. Requires overload protection to be included in control panel.

## OPTIONAL EQUIPMENT

Additional cord, tungsten carbide seal. **Includes 3" discharge flange.**



## SPECIFICATIONS

### Submersible Non-Clog Sewage Pump Series: 2BSE-SS

#### General:

Furnish and install a quantity of \_\_\_\_\_ Barmesa® Pumps submersible sewage pump(s), Model 2BSE\_\_\_\_SS, \_\_\_\_\_ HP, \_\_\_\_\_ RPM, \_\_\_\_\_ phase, 60 Hz, \_\_\_\_\_ volts, with a 2 inch (optional 3") vertical bolt-on discharge flange connection. Each pump shall be capable of delivering the following performance, \_\_\_\_\_ U.S. GPM at \_\_\_\_\_ ft total dynamic head, with a shut off head of \_\_\_\_\_ ft TDH minimum.

#### Pump Design:

The centrifugal sewage pump(s) shall be capable of handling 2 inch diameter spherical solids of raw, unscreened domestic sewage consisting of water, fibrous materials. The pump(s) shall be capable of handling liquids with temperatures to 104 °F continuous, and shall be capable of running dry for extended periods.

#### Pump Construction:

**Castings:** The volute, seal plates, impeller and motor housing shall be constructed of ASTM A-48 class 30 cast iron.

**Coating/Hardware:** Exterior surfaces shall be painted with a water based air dry enamel. All exposed hardware shall be 300 series stainless steel.

**Gaskets:** All gaskets shall be of the compression square ring type eliminating critical slip fits and the possibility of damage during service associated with sliding o-ring sealing arrangements.

**Impeller:** The impeller shall be of 2 vane, open type, nonclog design with pump out vanes on the back side. Impellers shall be capable of being trimmed to meet specific performance characteristics. The impeller shall be dynamically balanced to ISO G6.3 specifications.

**Mechanical seal:** A dual seal arrangement shall consist of a Buna-N exclusion seal and a single mechanical design operating in an oil-filled seal cavity. The seal shall be constructed of silicon carbide faces, 300 series stainless steel hardware, and all elastomer parts to be of Buna-N. The seal shall be commercially available and not a manufacturers proprietary design.

**Motor:** Design shall be of the split capacitor design for single phase units. The pump shall be designed to be non-overloading throughout the entire pump curve. The rotor and stator assembly shall be of the standard frame design and secured to the pump seal plate by four threaded fasteners allowing for easy serviceability.

The motor windings shall be of Class B insulation and operate in a sealed environment containing clean dielectric oil, making it capable of operating in a totally, partially or non-submerged condition for extended periods of time without damage due to the heat being generated. The used dielectric oil must be disposed of as non-hazardous waste. The motor shall meet the standard NEMA L for single phase and NEMA B for three phase.

**Thermal Protection:** All single phase motors shall have thermal protection with automatic reset. Three phase motors shall be equipped with a thermal switch embedded in the stator windings and require external overload protection in the control panel.

**Shaft:** The pump shaft shall be of a one-piece design and shall be of 416 stainless steel.

**Bearings:** The lower bearing shall be of the single row ball type to accept radial and thrust loads, and the upper bearing of the single ball type for radial loads. Bearings shall operate in an oil bath atmosphere for superior life.

**Power Cord:** Shall be \_\_\_\_\_ ft of type SJTOW on 115 volt and SOW on all other voltages and connected to the motor via Fast-Disconnect plug. Pin receptacles shall be crimped and molded to the power cord in a PVC plug. The plug shall be secured with a stainless steel compression plate to prevent water from entering the housing and to provide strain relief at the point of cord entry. A clamp shall compress the PVC molding against the cord jacket to prevent water from entering the jacket. A terminal block with brass pin inserts shall connect the power cord leads with the motor leads. The ground pin shall be longer than the other pins such that the ground connection is the first connection made and the last connection broken when the plug is inserted and removed, respectively. A Buna-N o-ring shall provide isolation sealing between the terminal block and the motor housing when the cord plug is removed. A three prong, grounded, 115 volt plug shall be molded to power cord for automatic operation.

**Tests and inspections:** Shall be performed by the pump manufacture.

1. A ground continuity check and motor chamber shall be Hi-potted to test for electrical integrity.
2. Check that motor voltage and frequency matches name plate.
3. The pump shall be pressurized and a air leak test is performed to ensure the integrity of the motor housing.
4. The pump is submerged and operated to determine the unit meets hydraulic performance requirements.

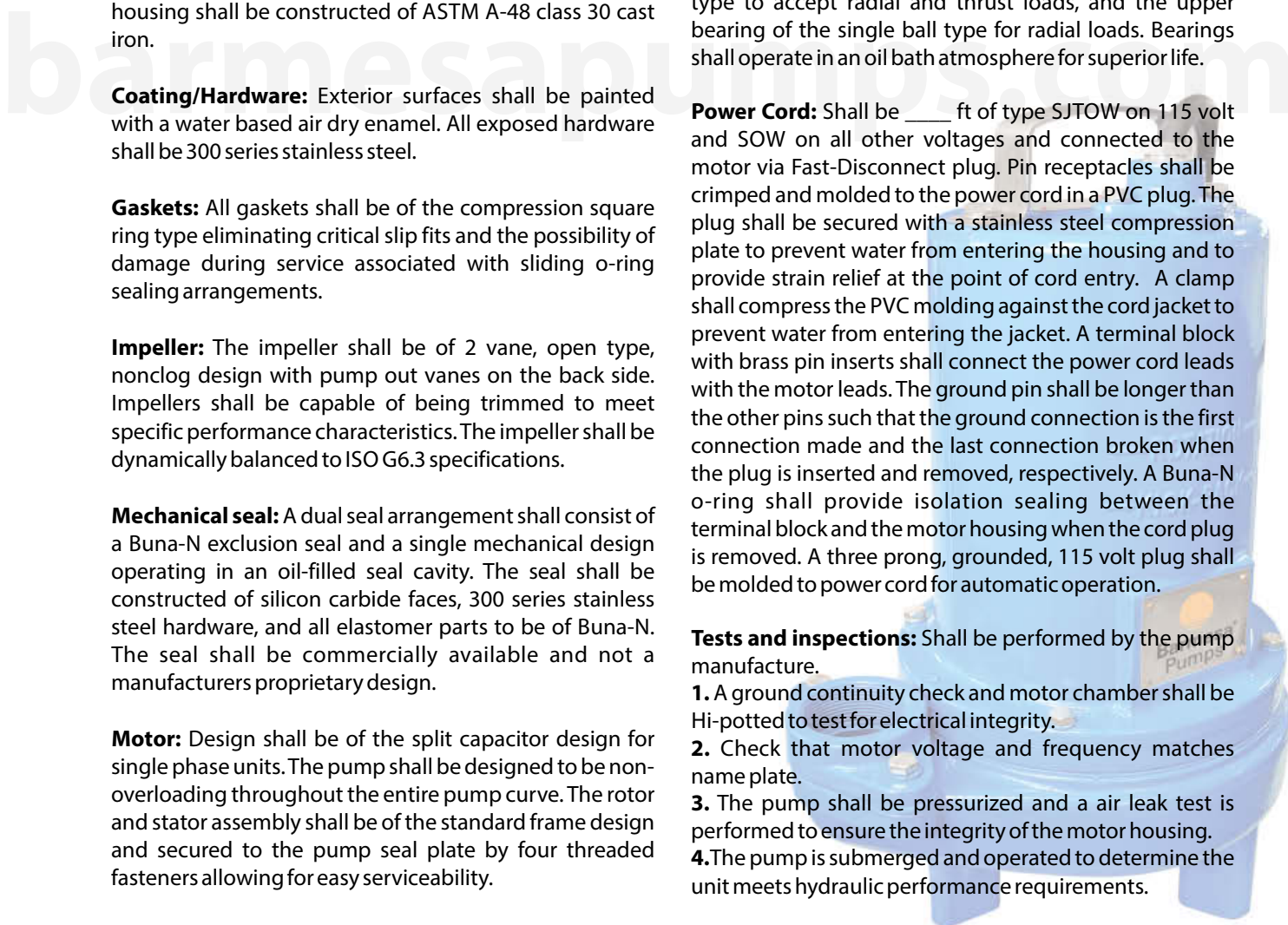

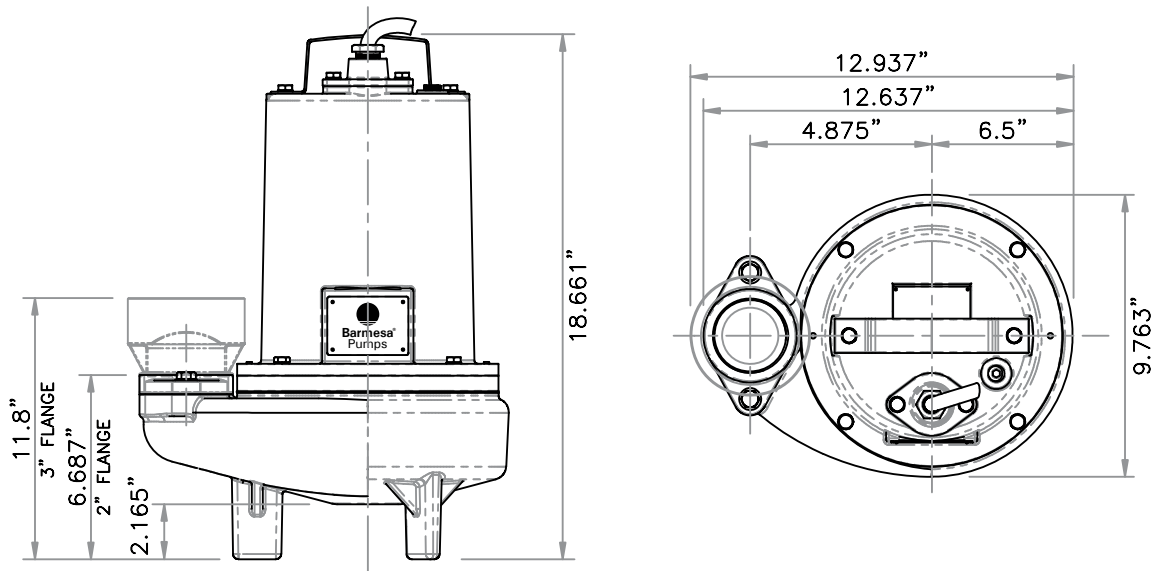

MODEL	PART No.	HP	VOLTS	PHASE	RPM (Nominal)	MAX AMPS	LOCKED ROTOR AMPS	NEMA CODE	CORD SIZE	CORD TYPE	CORD O.D.	WEIGHT (pounds)
2BSE51SS	62180501	0.5	115	1	1750	11.6	18.4	D	14/3	SEOOW	0.5"	77
2BSE52SS	62180502	0.5	230	1	1750	5.9	14.9	B	14/3	SEOOW	0.5"	77
2BSE53SS	62180503	0.5	200/230	3	1750	4.6/4.2	9.7/11.1	K	14/3	SEOOW	0.5"	77
2BSE54SS	62180504	0.5	460	3	1750	2.2	5.3	K	14/3	SEOOW	0.5"	77
2BSE72SS	62180505	0.75	230	1	1750	10.5	17.5	D	14/3	SEOOW	0.5"	84
2BSE73SS	62180506	0.75	200/230	3	1750	5.5	16	D	12/4	SEOOW	0.625"	84
2BSE74SS	62180507	0.75	460	3	1750	2.2	8	D	12/4	SEOOW	0.625"	84

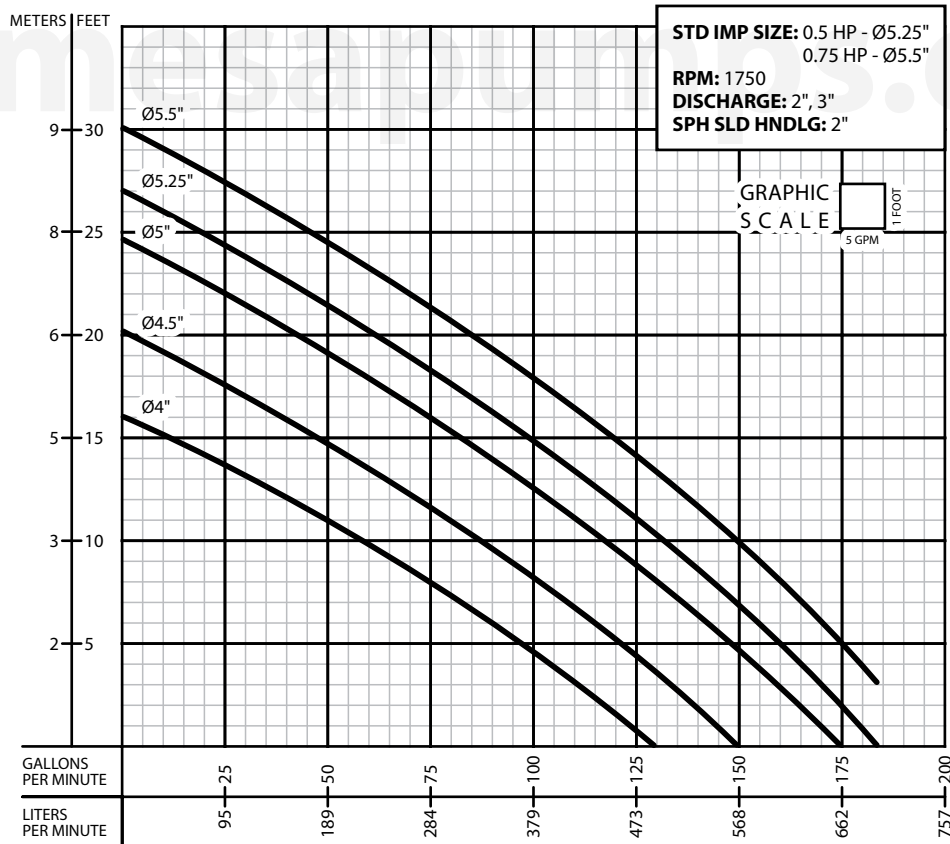

**IMPORTANT!**

1. Never use this pump to handle explosive liquids.
2. This pump is not approved to be used in swimming pools, recreational installations or any application where human contact may be common.
3. Pump may be operated "dry" for extended periods without damage to motor &/or seals.
4. Testing is performed with water specific gravity of 1.0 @ 68 °F (20 °C); other fluids may vary performance.