

# **BVL**

1 - 500 HP



**IMPORTANT!** - Read all instructions in this manual before operating or servicing a pump.

Before installation, read the following instructions carefully. Failure to follow instruction and safety information could cause serious bodily injury, death and/or property damage. Each Barmesa product is carefully inspected to insure proper performance. Closely following these instructions will eliminate potential operating problems, assuring years of trouble-free service.

**⚠ DANGER** "Danger" indicates an imminently hazardous situation which, if not avoided, WILL result in death or serious injury.

**⚠ WARNING** "Warning" indicates an imminently hazardous situation which, if not avoided, MAY result in death or serious injury.

**⚠ CAUTION** "Caution" indicates a potentially hazardous situation which, if not avoided, MAY result in minor or moderate injury.

**IMPORTANT! - Barmesa Pumps is not responsible for losses, injury or death resulting from failure to observe these safety precautions, misuse, abuse or misapplication of pumps or equipment.**

 **ALL RETURNED PRODUCTS MUST BE CLEANED, SANITIZED, OR DECONTAMINATED PRIOR TO SHIPMENT, TO INSURE EMPLOYEES WILL NOT BE EXPOSED TO HEALTH HAZARDS IN HANDLING SAID MATERIAL. ALL APPLICABLE LAWS AND REGULATIONS SHALL APPLY.**

**⚠ WARNING** Installation, wiring, and junction connections must be in accordance with the National Electric Code and all applicable state and local codes. Requirements may vary depending on usage and location.

**⚠ WARNING** Installation and servicing is to be conducted by qualified personnel only.

 Keep clear of suction and discharge openings. Do not insert fingers in pump with power connected; the rotating impeller can cause serious injury.

 Always wear eye protection when working on pumps. Do not wear loose clothing that may become entangled in moving parts.

**⚠ DANGER** Pumps build up heat and pressure during operation. Allow time for pumps to cool before handling or servicing the pump or any accessory items associated with or near the pump.

**⚠ DANGER** This pump is **not** intended for use in swimming pools or water installations where there is human contact with pumped fluid.

**⚠ DANGER** Risk of electric shock. To reduce risk of electric shock, always disconnect pump from power source before handling any aspect of the pumping system. **Lock out power and tag.**

**⚠ WARNING** Do not use these pumps in water over 77° F. Do not exceed manufacturers recommended maximum performance, as this could cause the motor to overheat.

**⚠ DANGER** Do not lift, carry or hang pump by the electrical cables. Damage to the electrical cables can cause shock, burns or death. **Never** handle connected power cords with wet hands. Use appropriate lifting device.

**⚠ WARNING** Sump and sewage pumps often handle materials which could cause illness or disease. Wear adequate protective clothing when working on a used pump or piping. Never enter a basin after it has been used.

**⚠ DANGER** Failure to permanently ground the pump, motor and controls before connecting to power can cause shock, burns or death.

**⚠ DANGER** These pumps are **not** to be installed in locations classified as hazardous in accordance with the National Electric Code, ANSI/NFPA 70.

**⚠ WARNING** The Uniform Plumbing Code (UPC) states that sewage systems shall have an audio and visual alarm that signals a malfunction of the systems, that are required to reduce the potential for property damage.

**IMPORTANT! - Prior to installation, record Model Number, Serial, Amps, Voltage, Phase and HP from pump name plate for the future reference. Also record the Voltage and Current Readings at Startup:**

Model Number: \_\_\_\_\_

Serial: \_\_\_\_\_

Amps: \_\_\_\_\_ Voltage: \_\_\_\_\_

Phase: \_\_\_\_\_ HP: \_\_\_\_\_

- CASING:** Cast iron ASTM A-48 class 30, horizontal suction and discharge. 150 PSI rated flange. With lubrication, drainage and pressure connections.
- IMPELLER:** Close type, cast iron ASTM A-48 class 30 or bronze ASTM-B584, Gr. C84400.
- SPLIT COUPLING:** Aluminum 6061-T6.
- SHAFT:** Stainless Steel 416.
- COUPLING:** Cast iron ASTM A-48 class 30.
- MECHANICAL SEAL:** Carbon/Silicon Carbide-Viton-SS304
- ELECTRIC MOTOR:** TEFC or ODP, vertical, "C" flange and standard shaft.

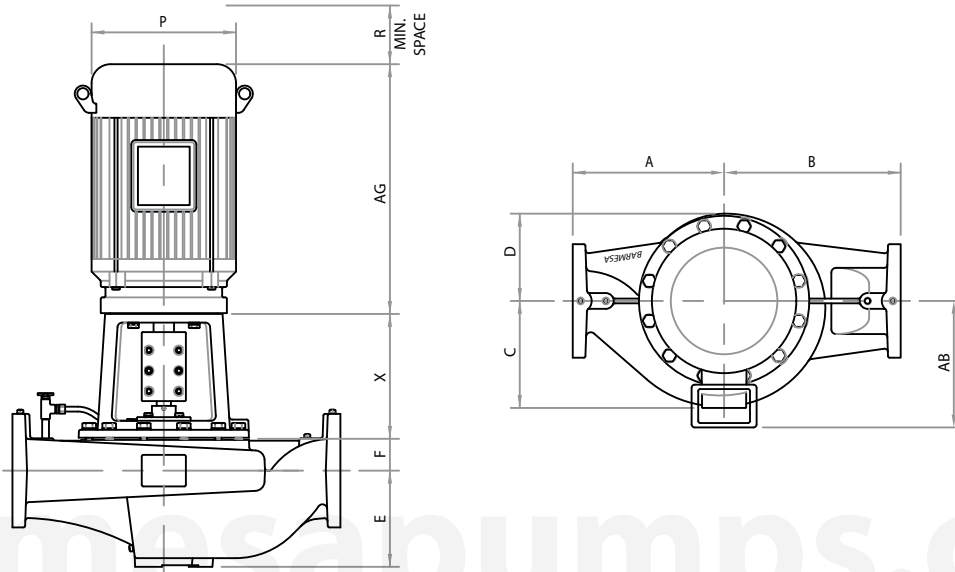

barmesapumps.com

Size	Dimensions					
	A	B	C	D	E	F
1.5 x 1.5 x 6	7	7.25	4.5	4.5	4.5	1.75
2 x 2 x 6	8	7	5.25	4.5	4.88	1.88
3 x 3 x 6	9.75	8.25	5.88	4.75	6	1.88
4 x 4 x 6	12	10	5.88	4.75	7.75	2.25
6 x 6 x 6	17.5	12	8.5	6.35	9.68	4
1.5 x 1.5 x 8	8	8	5.75	5.75	4.63	2.5
2 x 2 x 8	9.5	8.5	5.75	5.75	5.13	2.5
3 x 3 x 8	12	10	6.75	5.75	6.38	2.5
4 x 4 x 8	14	11	8	6.25	8	2.5
5 x 5 x 8	13	12	7.5	6.25	8	2.5
6 x 6 x 8	19.5	13.5	9.75	7.5	10.38	3.25
8 x 8 x 8	22	16	11	8.5	11.5	5.5
2 x 2 x 10	10	9	6.75	6.75	5.38	2.5
3 x 3 x 10	11.5	9.5	7.25	6.75	5.5	2.5
4 x 4 x 10	14	12	7.75	6.88	7.63	2.5
6 x 6 x 10	17	15	10.63	8.25	8.13	2.5
8 x 8 x 10	22	17	11.5	9	9.75	3
4 x 4 x 11.5	15.25	12.75	8.16	7.38	7.69	2.5
5 x 5 x 11.5	17.25	13.75	9.03	8.03	8.88	2.75
6 x 6 x 11.5	18.5	16.5	9.88	8.56	9.75	2.75
8 x 8 x 11.5	22	17.5	12	9.63	10	3.25
3 x 3 x 13	13.5	12	8.75	8.25	6.63	2.5
4 x 4 x 13	15.5	13.5	9.25	8.25	8.13	2.38
4 x 4 x 13L	15.5	13.5	9.25	8.25	8.13	2.38
6 x 6 x 13	19	17	11	9	10.25	2.75
8 x 8 x 13	23	19	12	9.75	10	2.94
10 x 10 x 13	26	21.38	14	11	16	3.25
12 x 12 x 13	22	24.25	17	12	12.5	12
8 x 8 x 15	25.88	22.88	13.88	11.5	12.38	3.25
10 x 10 x 15	26	22.5	14.5	11.5	13.44	3.25
14 x 14 x 15	25	27	20.1	13.5	13.75	13.88

Frame	Dimensions				
	AG	AB	P	R	SHAFT Ø
143TC	9.88	6.5	6.9	5	0.875
145TC	11.1				
182TC	11.62	7.38	8.9	5	1.125
184TC	12.62				
213TC	14.88	9	10.62	5	1.375
215TC	15.88				
254TC	18.5	9.9	12.62	6	1.625
256TC	20.25				
284TC	23	12.94	14.19	8	1.875
284TSC	23				1.625
286TC	24.5	24.5	15.94	10	1.875
286TSC	24.5				1.625
324TC	27	15.75	15.94	10	2.125
324TSC	26.5				1.875
326TC	27	15.75	17.81	12	2.125
326TSC	26.5				1.875
364TC	28.5	17.69	17.81	12	2.375
364TSC	28.5				1.875
365TC	28.63	17.69	17.81	12	2.375
365TSC	28.63				1.875
404TC	32.5	17.5	19.9	14	2.875
404TSC	32.5				2.125
405TC	32.5	17.5	19.9	14	2.875
405TSC	32.5				2.125
444TC	37.31	19.94	21.9	16	3.375
444TSC	37.31				2.375
445TC	37.31	19.94	21.9	16	3.375
445TSC	37.31				2.375
447TC	40.88	19.94	21.9	20	3.375
447TSC	40.88				2.375
449TC	45.85	19.94	21.9	20	3.375
449TSC	45.85				2.375

Impeller diameter	Dimensions		Impeller diameter	Dimensions	
	Frames	X		Frames	X
6"	143 - 145TC	8.75	13"	182 - 256TC	12.5
	182 - 256TC	10.5		284 - 286TC	13.25
8"	143 - 145TC	8.25	13"	324 - 326TC	14
	182 - 256TC	10		444 - 445TC	14.75
	284 - 286TSC	13		364 - 365TC	15.25
	324 - 326TSC	13.75		404 - 405TC	16
10"	143 - 145TC	8.25	14"	444 - 449TC	16.75
	182 - 256TC	10		364 - 365TC	15.26
	284 - 286TC	10		404 - 405TC	16
11.5"	326 - 326TC	135	15"	444 - 446TC	16.5
	182 - 256TC	9.88		447 - 449TC	17
	284 - 286TC	12.88		364 - 365TC	16.75
	324 - 326TC	14.12		404 - 405TC	18.38
				444 - 449TC	18.38

## ► Receiving inspection

Upon receiving the pump, it should be inspected for damage or shortages. If damage has occurred, file a claim immediately with the company that delivered the pump. If the manual is removed from the packaging, do not lose or misplace.

## ► Storage

Any product that is stored for a period longer than six (6) months from the date of purchase should be bench tested prior to installation. A bench test consists of, checking the impeller to assure it is free turning and a run test to assure the motor (and switch if provided) operate properly. Do not pump out of liquid.

## ► Location

Locate the unit as close as possible to the liquid being pumped in order to reduce friction losses in the suction pipe. Suction and discharge piping should be perfectly aligned with the pump flanges and supported independently using pipe hangers or floor mounted supports.

*\*\*Consult pipe friction table and accessories in order to determine your piping dimensions.*

## ► Suction

Recommended to use robust and self-supported piping and inspect for any leakage.

For a successful installation you need to rely on the friction loss calculation in the suction part taking into consideration the acceptable limits. The minimum suction pipe to be used can be determine by comparing the NPSH available in the suction part versus the NPSH require by the impeller, as illustrated in the performance curve.

Generally, we recommend to use ½" to 1" bigger diameter piping to what the pump suction diameter is.

## ► Typical installation diagrams for BVL's

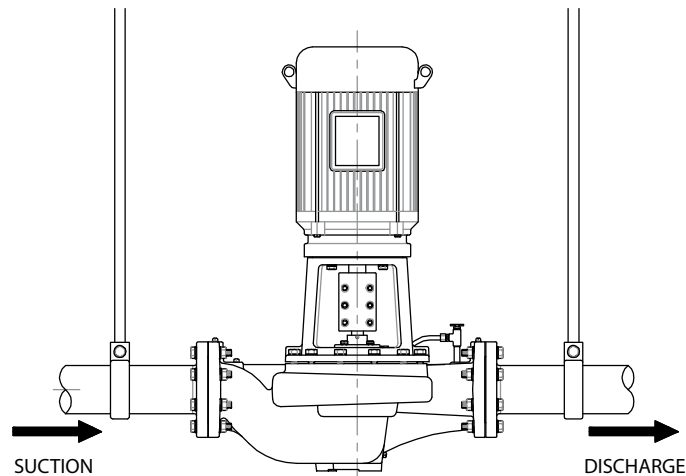

HANGER SUPPORTED  
PIPE MOUNTED

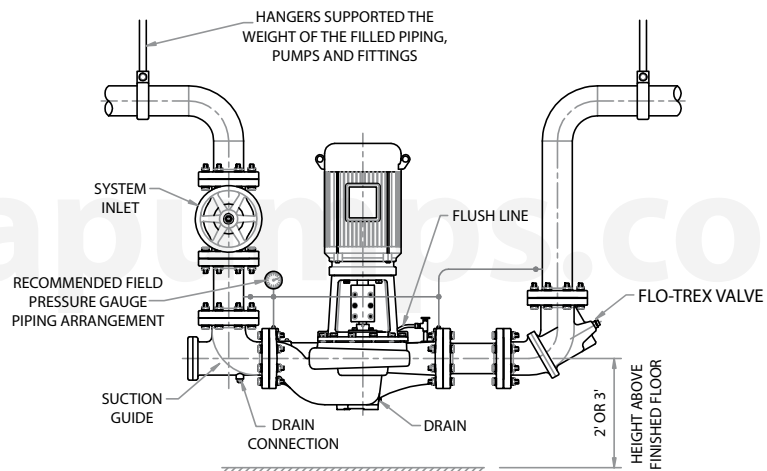

PIPE MOUNTED SUPPORTED AT CEILING

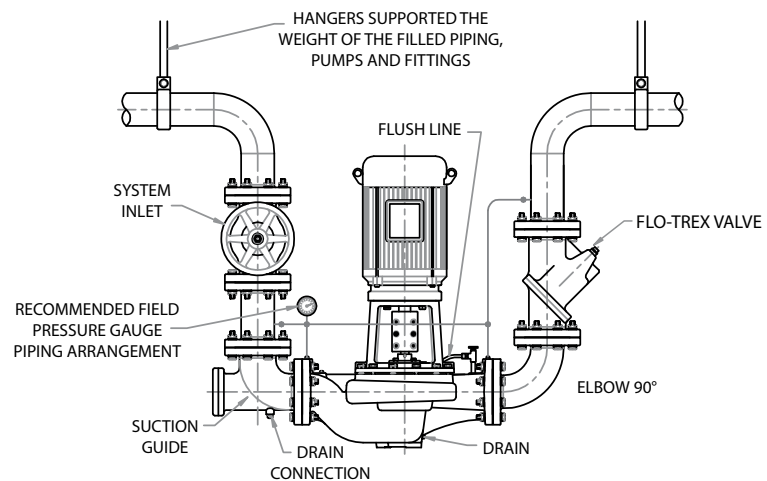

DISCHARGE ELBOW FOR MINIMUM FOOTPRINT

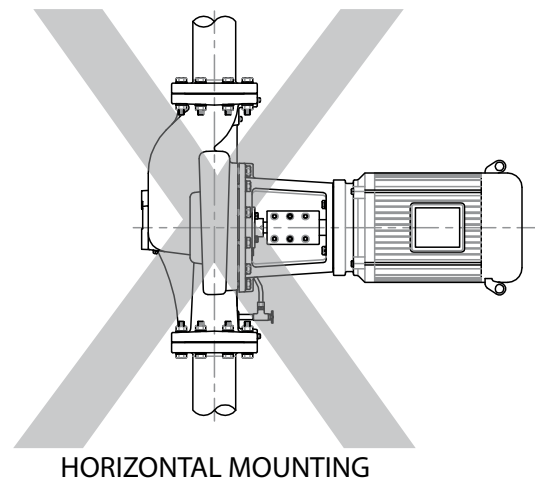
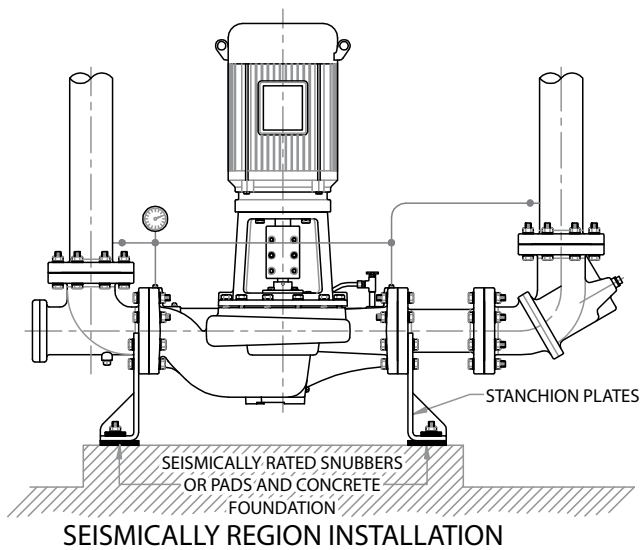
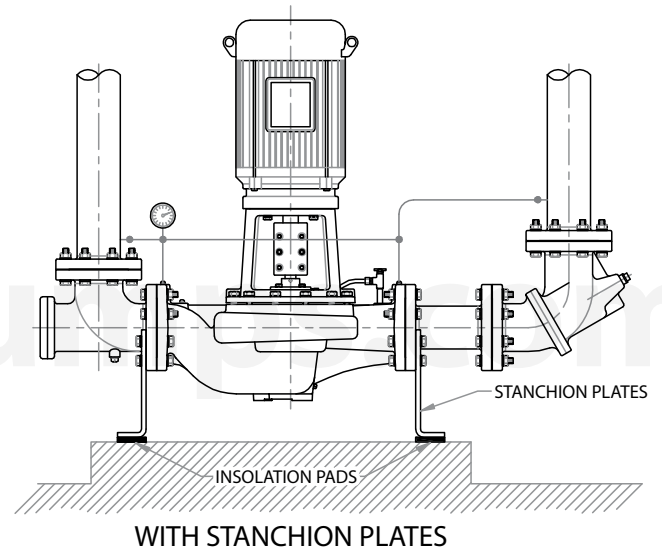
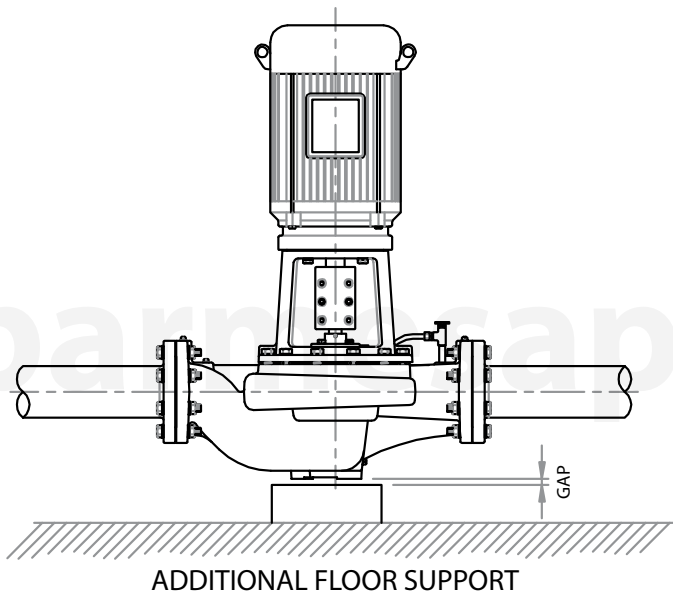
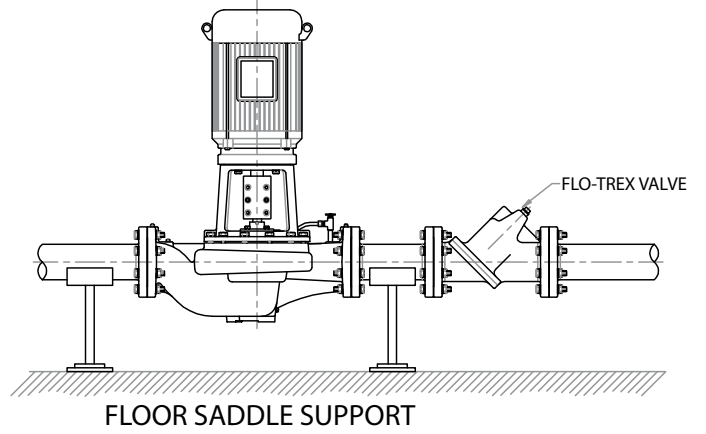
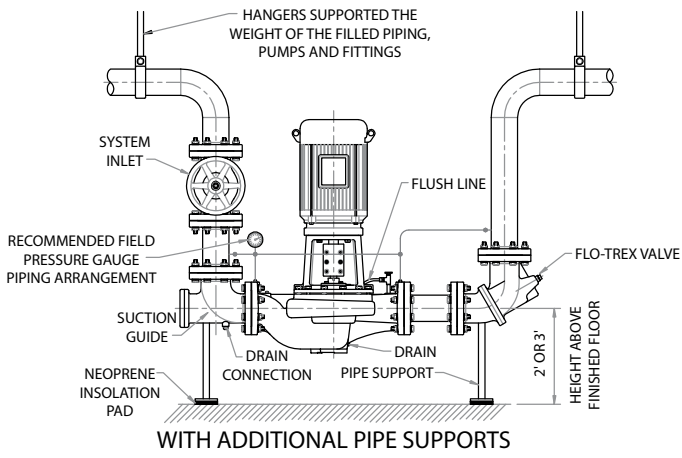

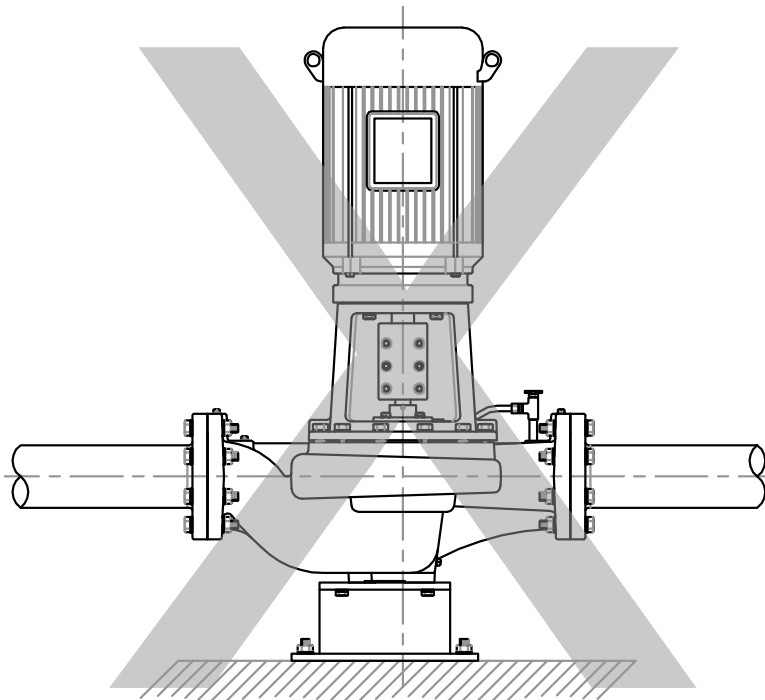

MOUNTED ON RIGID BASE  
WITHOUT FLEXIBLE CONNECTORS

► **Discharge**

Recommended to use robust and self-supported piping to maintain the pump stable and firm during operation.

Due to the high energy cost or BHP necessary to overdue friction generated by using a small diameter pipe, usually a large diameter pipe is used in the discharge side.

Piping, valves, etc. should be perfectly aligned with the suctions and discharge line and supported to avoid excessive force on the pump casing. If necessary install expansion joints to protect from any thermal or pressure force.

barmesapumps.com

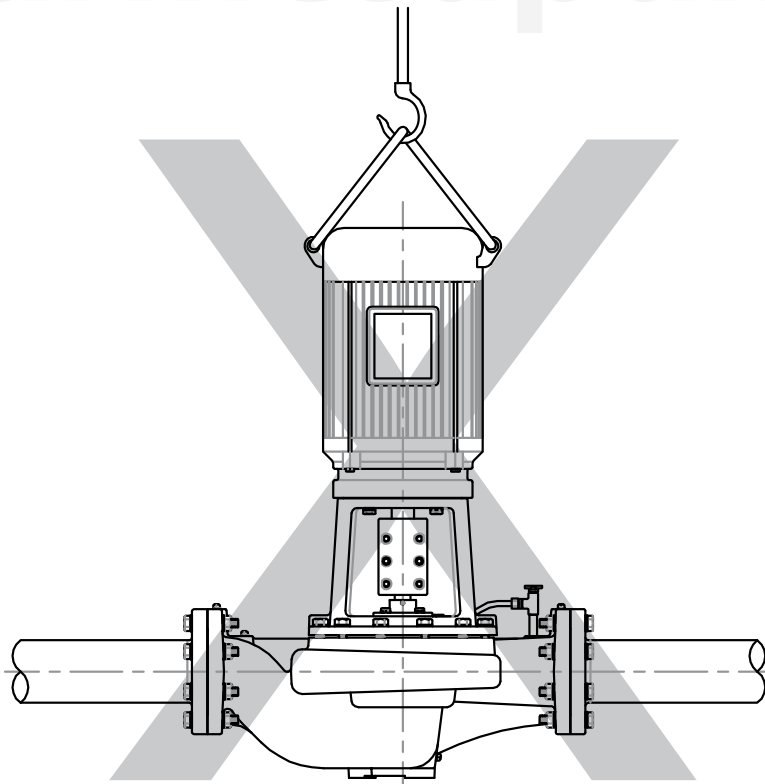

MOTOR LIFTING  
HOOK SUPPORTED

## ► Priming

The pump must be fully primed before start up, fill the casing with liquid and rotate shaft by hand in order to remove any trapped air in the impeller.

Install a foot valve in the suction side and fill with liquid through the upper part. Remove the male plug locate on the superior part of the casing until liquid comes out, then seal the male plug.



**IMPORTANT!** - Do not operate the pump without being fully primed.

## ► Rotation

Rotation is indicated by the directional arrow marked on the pump casing. If motor is operated in three phase, it is very important that motor shaft rotation match the direction as the directional arrow on casing. Energize the motor momentarily and check for the correct shaft rotation. Do not let the pump operate against the directional arrow.

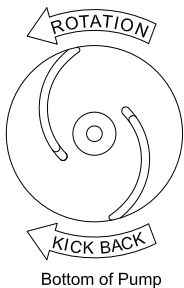

## ► Starting the Pump

Start the pump with the discharge valve 90% close. Gradually open the discharge valve until motor is at operating speed. Never allow the amperage consumed by the pump exceeds the maximum allowed by the engine.

## ► Mechanical Seal

The mechanical seal installed in BVL models are water lubricated, do not run the pump unless properly filled with water. Different kind of seals are used of a distinctive operational use and liquid being pumped, consult your Barmesa Pumps distributor for more information.

## ► Repair, Maintenance & Service



**IMPORTANT!** - Always de-energize the motor and lose the discharge valve before any repair, maintenance or service perform on the pump.

## ► Remove the Mechanical Seal

The BVL model features an external mechanical seal which facilitates the mechanical seal replacement without the need to remove the pump or motor, saving time and money.

Begin by disconnecting power to the motor and locked and seal the power supply so the motor doesn't not accidentally start. Close the suction and discharge valve and drain the remaining liquid by removing the plug, once all the liquid is drained reinstall the plug.

Remove the coupling guard to gain access to the mechanical seal.

Using the "Allen" wrench loosen and remove the coupling bolts from the split coupling. Separate the coupling house gently in order to avoid damage in the coupling. Remove the second half of the coupling and note that the pump shaft will drop down as you do this.

Remove both the motor shaft key and pump shaft key. Do not remove the motor shaft collar, this will help you on the coupling reinstallation.

Place a wrench on the hole in the pump shaft to keep it from rotating and continue to remove the cap screw, lock washer and collar from the pump shaft. There you will find a minimum distance of 35 mm (1-3/8") between the pump shaft and motor shaft.

Inspect shaft in order to find any bump or damage part, correct if necessary.

Remove the mechanical seal rotating assembly by sliding it up the pump shaft and slipping it through the gap between shafts.

Remove the connector and cooling seal flush piping connected in the seal plate. Remove the 4 screws and lock washers that hold the seal plate and remove the mechanical seal stationary part with its gaskets

## ► Replace the Mechanical Seal

Be precautious while handling the mechanical seal and avoid any damage or scratches on the seal faces. Do not touch the seal faces as this may affect the mechanical seal performance.

Replace the stationary seal with the large gasket down and make sure the seal flush hole is position towards the flush line connection.

Install the seal plate on the pump with the seal flush hole aligned to the seal flush hole on the stationary seal.

Place the seal plate bolts and washers, make sure to hand tighten evenly.

Carefully, in a diagonal pattern, tighten each bolt evenly giving them a few turns.

- ÿ Repeat pattern until all the bolts have been completely tighten. Do not over tighten this bolts, it may damage the pumps casing and stationary seal.
- ÿ Once the stationary part and the seal plate have been installed, using silicon lubricant, lightly lubricate the Viton seal O-ring. This will help to position the assembly down the shaft.
- ÿ Inspect the pump shaft and look for imperfections that may damage the mechanical seal O-ring. In case you find one make sure to correct this imperfections.
- ÿ Slide the rotating assembly carefully down the pump shaft onto the stationary seal.
- ÿ Install the collar, lock washer and cap screw and place a wrench on the hole in the pump shaft to keep it from rotating, tighten the cap screw.
- ÿ Place the key on the motor shaft and pump shaft.
- ÿ Identify the coupling half that is machined to receive the two shafts keys. Slide the coupling between the two shafts and position the motor collar in the coupling. (motor collar was not removed)
- ÿ To connect the pump shaft collar to the coupling half you will need to slightly raise the shaft using an Allen key or a wrench inserted in the shaft hole.
- ÿ Place the second half of the coupling and insert the coupling bolts and washers. Hand tighten them at this point.
- ÿ Make sure both motor shaft and pump shaft rotate freely.
- ÿ Adjust the mechanical seal rotating assembly on top of the stationary seal and tighten the set screw.
- ÿ Remove the holding clips with a small flat head screwdriver.
- ÿ Open discharge and suction valves and make sure the pump is primed.
- ÿ To ensure a proper priming, open the plug in the mechanical seal lubrication line until liquid starts bursting out, then close it. Now you can re-energize the motor and reconnect the power supply.



When ordering repair parts always provide the following information:

- Y Pump serial number:
- Y Pump model:
- Y Pump Part number:
- Y Part description:
- Y Quantity required:
- Y Shipping instructions:

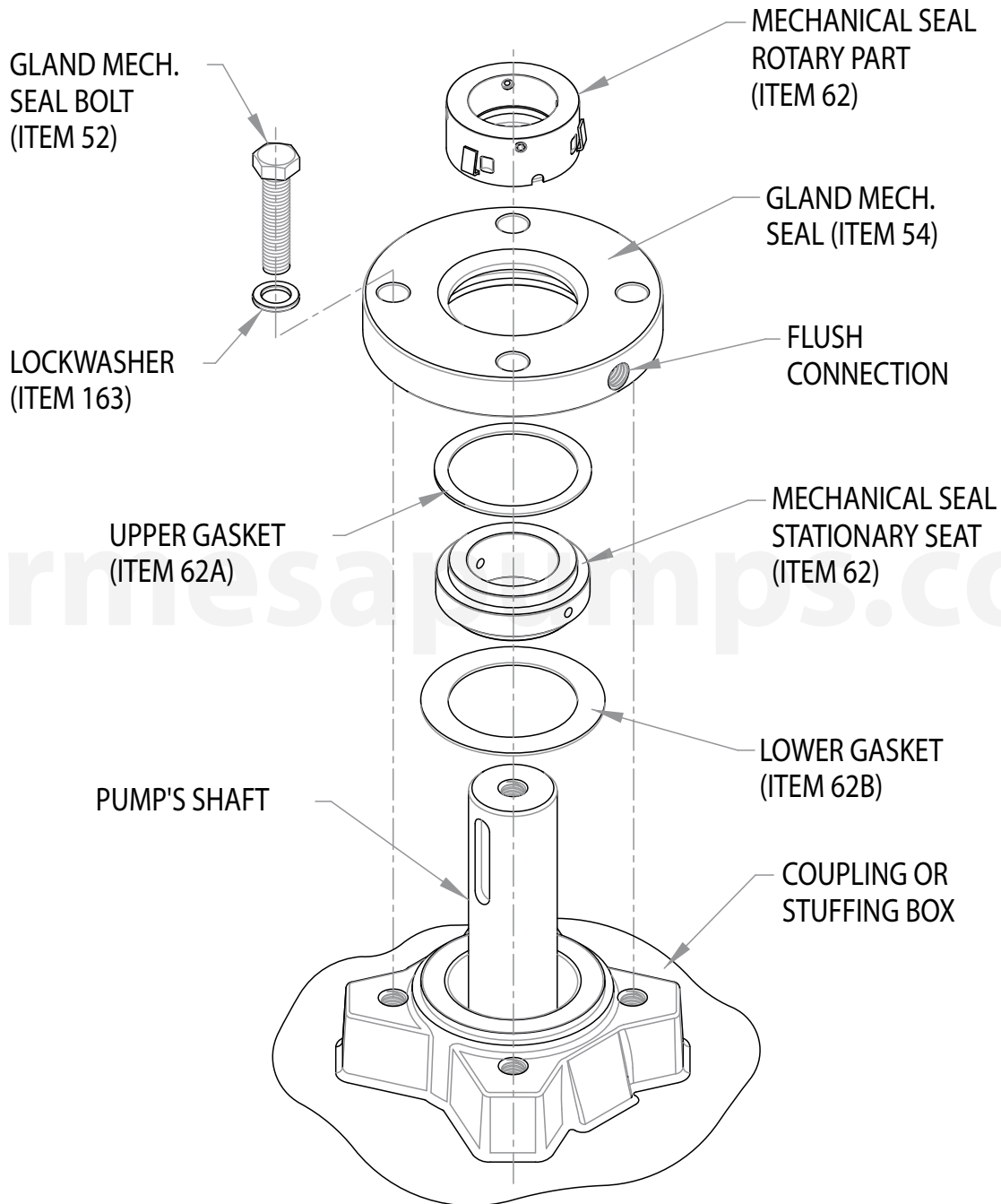

EXPLODED VIEW  
OUTBOARD MECH. SEAL

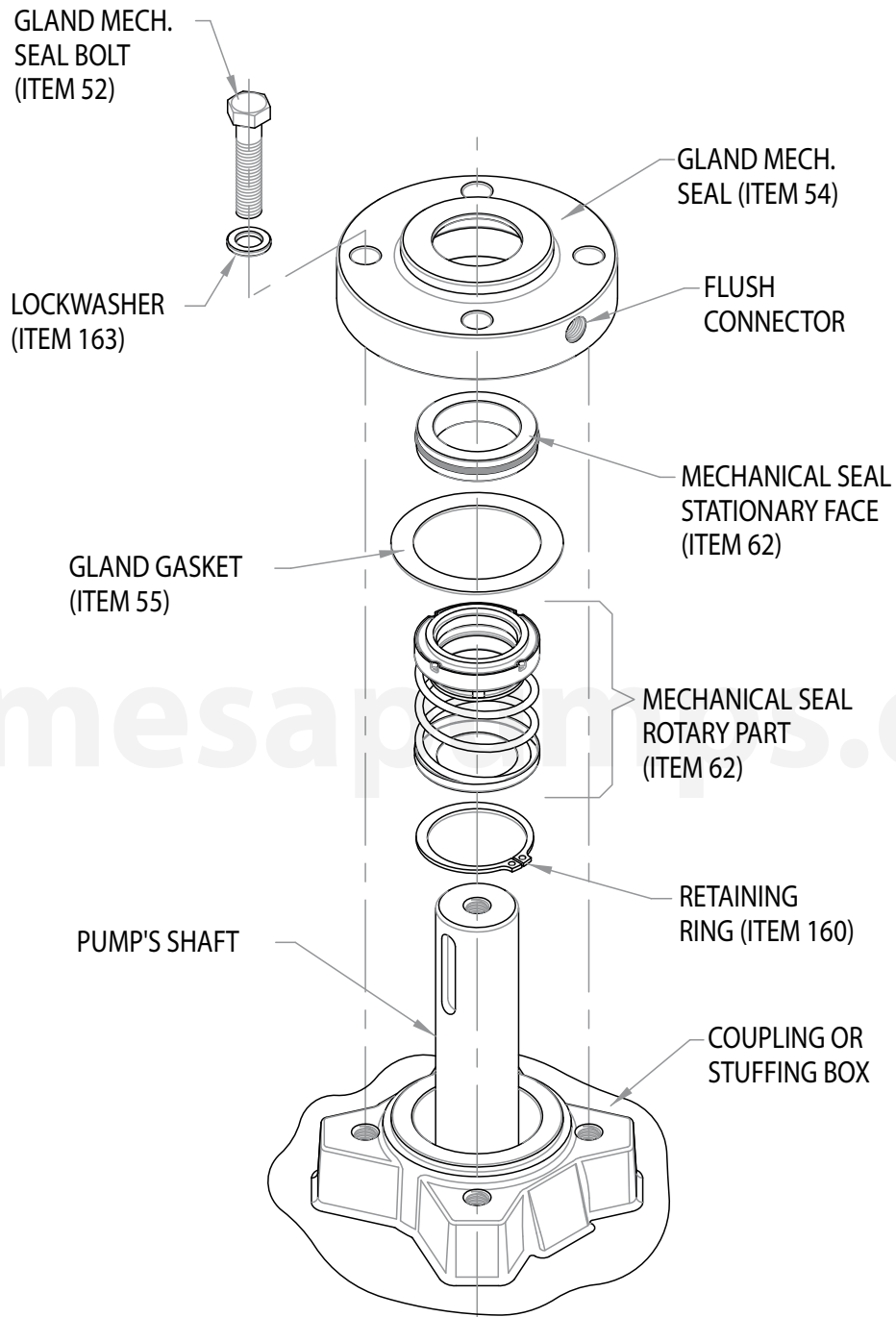

EXPLODED VIEW  
INBOARD MECH. SEAL

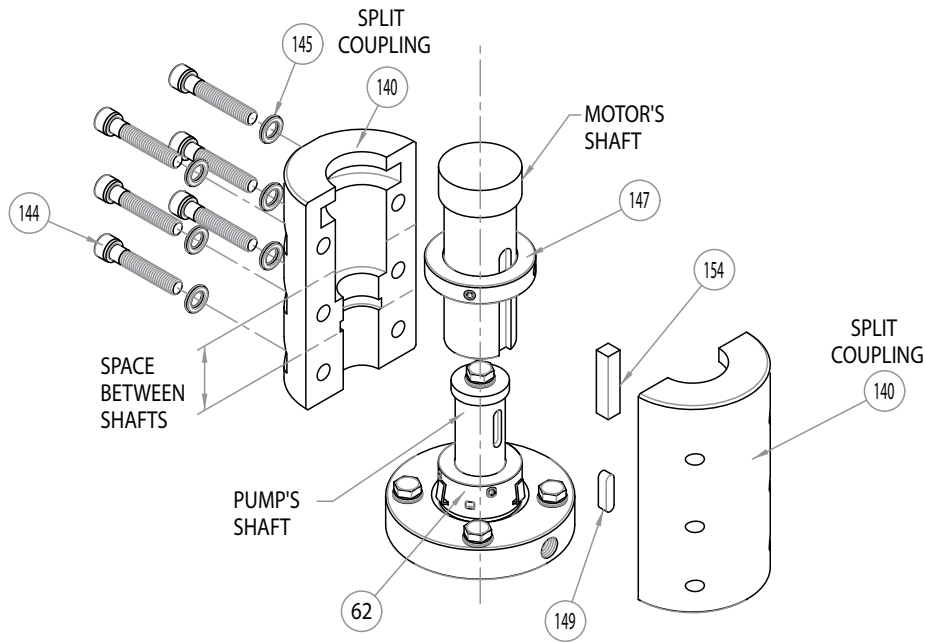







ITEM 140 PART #	MOTOR		SPACE BETWEEN	PUMP SHAFT'S Ø	ITEM 62 PART #	ITEM 147 PART #		
	FRAME	Ø SHAFT'S						
30405001	143-145 TC	7/8"	1 3/8"	1 1/8"	31030250	31030501		
30405002	182-184 TC	1 1/8"	2 1/2"			31030502		
30405003	213-215 TC	1 3/8"	2"			31030503		
30405004	254-256 TC	1 5/8"	1 3/8"			31030504		
30405005	284-286 TSC	1 5/8"	2 3/4"			31030505		
30405006	324-326 TSC	1 7/8"	2 7/8"	1 5/8"	31030251	31030506		
	364-365 TSC					31030505		
30405007	404-405 TSC	2 1/8"	2 3/8"			31030506		
30405008	284-286 TC	1 7/8"	1 3/8"			31030505		
30405009	324-326 TC	2 1/8"				31030506		
30405010	364-365 TC	2 3/8"				1 3/8"	31030507	
	445-447 TSC						31030502	
30405011	182-184 TC	1 1/8"	2 1/2"			2 1/8"	31030252	31030503
30405012	213-215 TC	1 3/8"	2"					31030504
30405013	254-256 TC	1 5/8"	1 3/8"					31030506
30405014	324-326 TC	2 1/8"	1 3/8"	31030507				
30405015	364-365 TC	2 3/8"	2 1/2"	31030508				
30405016	404-405 TC	2 7/8"	1 3/8"	31030509				
30405017	444-445 TC	3 3/8"	1 3/8"					
	447-449 TC							

FRICTION TABLE IN METERS x 100m OF PIPE												
LITERS PER MINUTE	PIPING DIMENSIONS IN INCHES											GALLONS PER MINUTE
	1"	1 1/4"	1 1/2"	2"	2 1/2"	3"	4"	5"	6"	8"	10"	
30	4.54											8
37	6.86	1.77										10
45	9.62	2.48										12
57	16.2	4	1.53									15
68	20.6	5.22	2.42									18
76	25.1	6.34	2.94									20
95	38.7	9.6	4.48	1.2	0.54							25
113	54.6	13.6	6.26	1.82	0.75							30
151	95	23.5	10.79	3.1	1.28							40
170	119	29.4	13.45	3.85	1.6							45
189	146	36	16.4	4.67	1.94	0.66						50
208		43.2	19.7	5.51	2.33	0.79						55
227		51	23.2	6.59	2.72	0.92						60
246		59.6	27.1	7.7	3.17	1.07						65
265		68.8	31.3	8.86	3.63	1.22						70
284		78.7	35.8	10.15	4.14	1.39						75
303		89.2	40.5	11.4	4.66	1.57						80
322		100	45.6	12.6	5.27	1.77						85
360		125	56.5	15.8	6.49	2.18	0.57					95
378		138	62.2	17.4	7.11	2.39	0.62					100
416			75.25	21.05	8.55	2.88	0.75					110
454			88.3	24.7	10	3.37	0.88					120
530			119	33.2	13.5	4.51	1.17	0.38				140
568			137.5	38.1	15.45	5.16	1.33	0.43				150
605			156	43	17.4	5.81	1.49	0.48				160
643				48.55	19.65	6.54	1.67	0.54				170
681				54.1	21.9	7.28	1.86	0.6				180
757				66.3	26.7	8.9	2.27	0.73	0.3			200
833				80	32.2	10.07	2.72	0.87	0.35			220
908				95	38.1	12.6	3.21	1.03	0.41			240
984				111	44.5	14.7	3.74	1.2	0.48			260
1060				128	51.3	16.9	4.3	1.38	0.56			280
1135				146	58.5	19.2	4.89	1.58	0.63			300
1324					79.2	26.1	6.55	2.11	0.85			350
1514					103	33.9	8.47	2.72	1.09	0.27		400
1892						52.5	13	4.16	1.66	0.42		500
2082						63.2	15.7	4.94	2	0.5		550
2271						74.8	18.6	5.88	2.34	0.59	0.19	600
2649						101	25	7.93	3.13	0.79	0.25	700
2838							28.7	9.07	3.59	0.91	0.29	750
3028							32.4	10.22	4.04	1.02	0.32	800
3217							36.6	11.56	4.5	1.13	0.36	850
3406							40.8	12.9	5.05	1.27	0.41	900
3595							45.5	14.35	5.61	1.42	0.45	950
3785							50.2	15.8	6.17	1.56	0.5	1000
4163								19.15	7.41	1.87	0.6	1100
4542								22.5	8.76	2.2	0.7	1200
4920								26.45	10.2	2.56	0.81	1300

NOTE: The values in this table refer to frictions and clean water pipes and hoses smooth walls. As used pipe and / or hose rough walls increase the values about 50% to 100%.

EQUIVALENT LENGTH IN METERS OF STRAIGHT PIPE AND VALVE CONNECTIONS FOR CALCULATING FRICTION.

PART	DESCRIPTION	DIAMETER									
		1"	1 1/4"	1 1/2"	2"	2 1/2"	3"	4"	5"	6"	
	STANDARD 90° ELBOW	0.84	1.07	1.22	1.68	1.98	2.44	3.35	4.12	4.88	
	MEDIUM RADIUS ELBOW 90°	0.69	0.92	1.07	1.37	1.68	2.14	2.75	3.51	4.27	
	LONG RADIUS ELBOW 90°	0.54	0.69	0.84	1.07	1.37	1.6	2.14	2.75	3.36	
	STANDARD 45° ELBOW	0.38	0.54	0.61	0.77	0.92	1.15	1.53	1.83	2.29	
	STANDARD TEE	1.68	2.29	2.75	3.36	4.28	5.19	6.71	8.23	10.1	
	ANGLE GLOBE VALVE (OPEN)	3.97	5.49	6.71	8.23	10.7	12.2	16.8	21.3	25.9	
	GLOBE VALVE (OPEN)	7.93	10.7	13	16.8	21.3	24.4	35.1	42.7	48.8	
	GATE VALVE (OPEN)	0.19	0.25	0.29	0.38	0.43	0.54	0.69	0.84	1.07	
	INCREASER	1.21	1.52	1.82	2.74	3.35	4.26	6.09	7.92	10.1	
	REDUCER	0.3	0.3	0.3	0.61	0.61	0.9	1.21	1.21	2.13	
	SUCTION VALVE	0.91	1.21	1.52	2.13	2.74	3.35	4.87	6.4	7.92	

# COUPLING & BUSHING SUBASSEMBLY

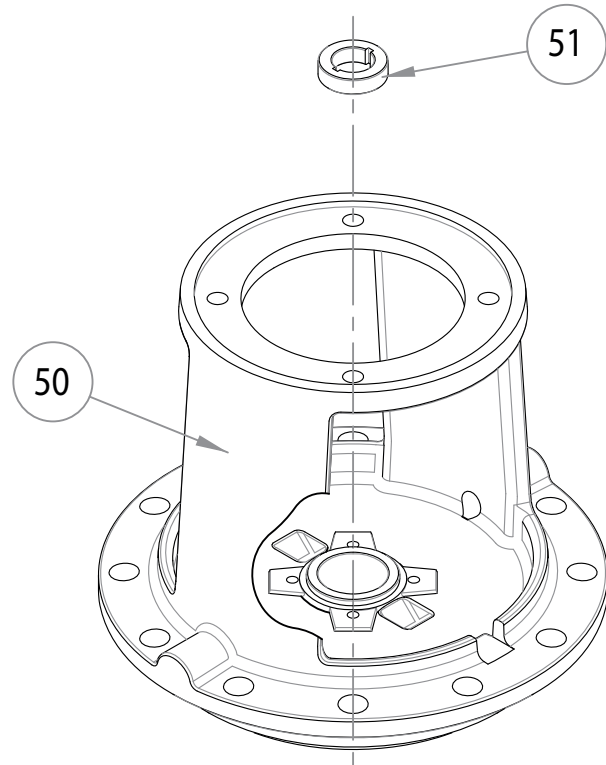

barmesapumps.com

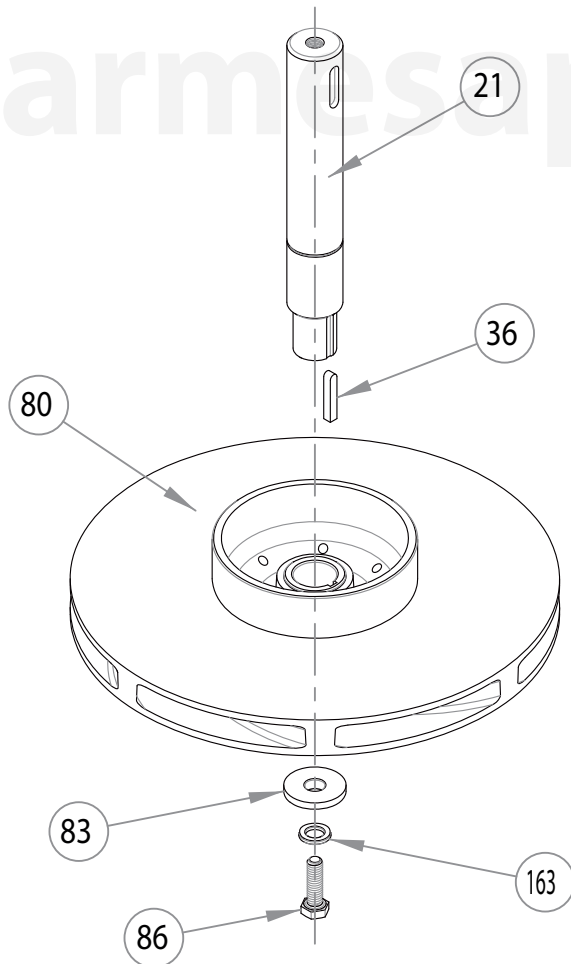

# IMPELLER & SHAFT SUBASSEMBLY

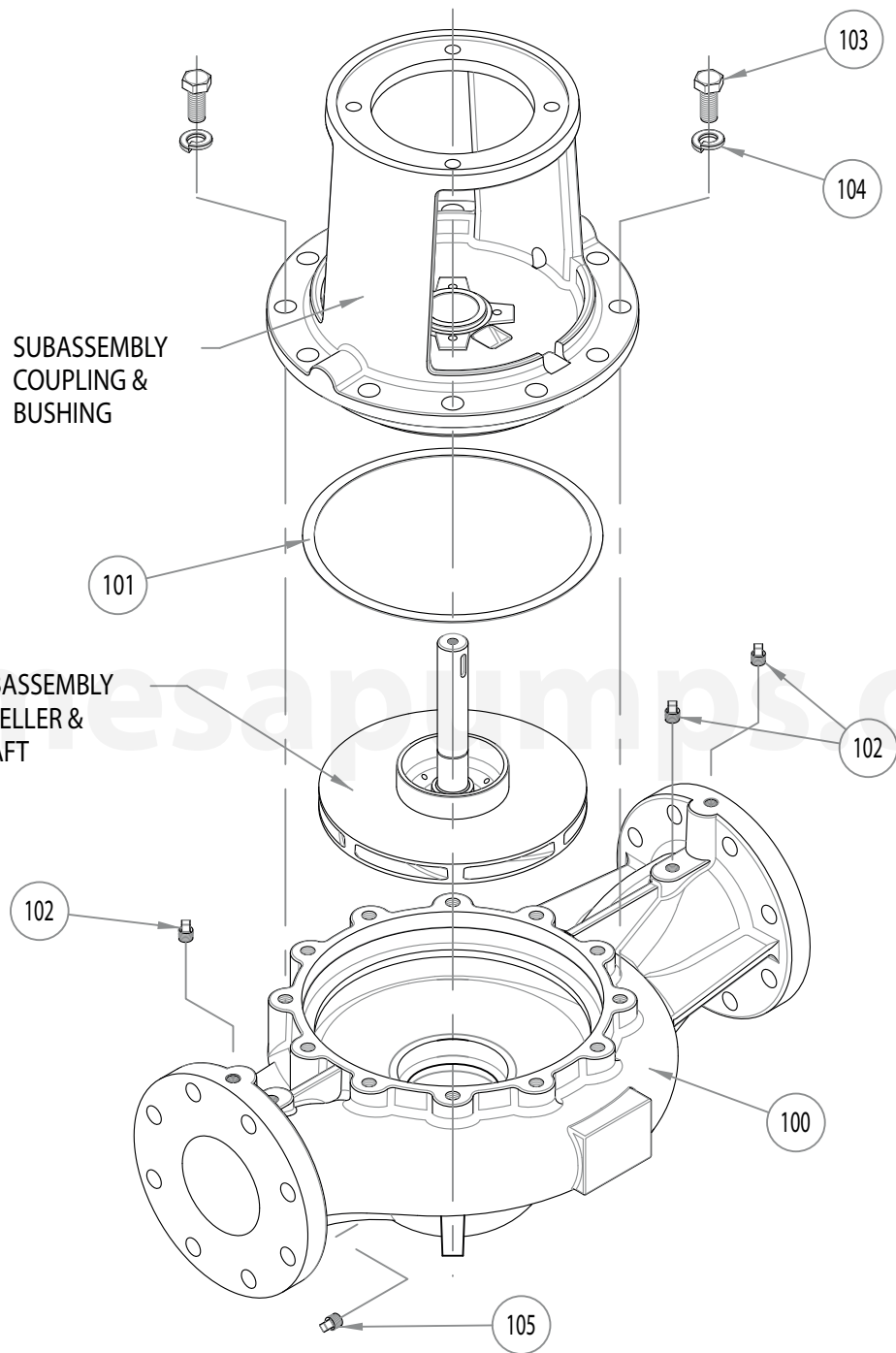

# VERTICAL IN-LINE PUMP

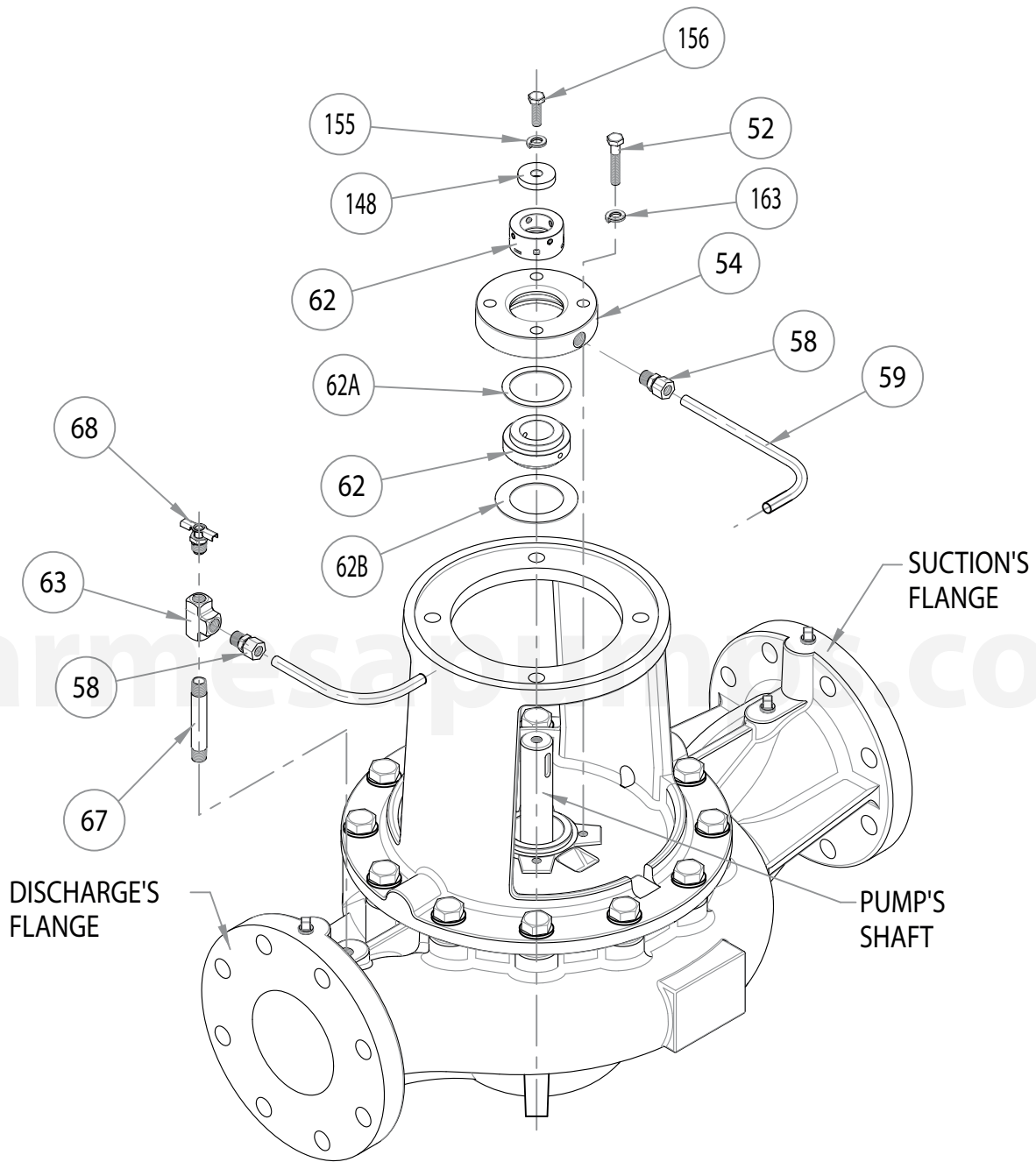

## MECHANICAL SEAL & FLUSH



ITEM	DESCRIPTION	MATERIAL
21	SHAFT	STAINLESS STEEL 416
36	IMPELLER KEY	CARBON STEEL 1018
40	ADAPTER	CAST IRON ASTM-A48, CLASS 30
43	WASHER	CARBON STEEL
44	MOTOR CAPSCREW	
50	COUPLING	CAST IRON ASTM-A48, CLASS 30
50A	SEAL PLATE	
51	BUSHING	GRAPHITE
52	SEAL COVER CAPSCREW	STAINLESS STEEL 304
54	SEAL GLAND	STAINLESS STEEL 316
58	MALE STRAIGHT CONNECTOR	BRONZE
59	TUBING	COPPER
62	MECHANICAL SEAL	CARBON/SILICON CARBIDE-VITON-SS
62A	UPPER GASKET	NON ASBESTOS OR TEFLON (PTFE)
62B	LOWER GASKET	
63	TEE	BRONZE
64	REDUCING BUSHING	
67	NIPPLE	
68	AIR VENT	
80	IMPELLER	CAST IRON OR BRONZE*
83	IMPELLER WASHER	STAINLESS STEEL 304
86	IMPELLER SCREW	
100	CASING	CAST IRON ASTM-A48, CLASS 30
101	CASING GASKET	NON ASBESTOS OR TEFLON (PTFE)
102	GAUGE PLUG	GALVANIZED STEEL
103	CASING CAPSCREW	CARBON STEEL
104	WASHER	
105	CASING DRAIN PLUG	GALVANIZED STEEL OR CAST IRON
140	COUPLING	ALUMINIO 6061-T6
144	SOCKET SCREW	CARBON STEEL
145	WASHER	
146	STUD BOLT	
147	MOTOR COUPLER COLLAR	STEEL 1045
148	SHAFT COUPLER COLLAR	
149	COUPLER KEY	STEEL 1018
150	GUARD	STEEL ASTM-A36
154	MOTOR KEY	STEEL 1018
155	CAPSCREW LOCKWASHER	CARBON STEEL
156	COUPLER COLLAR CAPSCREW	
163	WASHER	STAINLESS STEEL 304

\* ASTM-B584, Gr. C84400 (OPTIONAL)

For Repair Part Please supply: Model Number and Serial as shown on Name Plate, and Part Description and Part Number as shown on Parts List.



**Risk of electric shock. Always disconnect the pump from the power source before handling inspections or repairs.**

Symptom	Possible Cause(s)	Corrective Action
A) The pump does not prime, the vacuum gauge indicates a lower reading than normal.	<ol style="list-style-type: none"> <li>1. Air leak in the suction system.</li> <li>2. Insufficient liquid in the pump casing.</li> <li>3. Low operating speed.</li> <li>4. Bound pump.</li> <li>5. Mechanical defect.</li> </ol>	Threaded joints in the suction tightness. Gaskets for no wear. The mechanical seal for leaks. The drain plug has leaks. The vacuum gauge may be leaking. That the pump's body is filled with water. The motor speed. (RPM) Impeller rotates freely. Internal parts are clean. That the internal parts are not worn.
B) The pump does not prime, the vacuum gauge reading indicates higher than normal.	<ol style="list-style-type: none"> <li>1. Pipe clogged suction.</li> </ol>	The suction line is clean
C) The pump priming good vacuum gauge reading is normal, the manometer indicates a lower pressure than normal.	<ol style="list-style-type: none"> <li>1. The pump speed is very low.</li> <li>2. Mechanical defects.</li> </ol>	The voltage is correct. The internal parts for wear.
D) The pump priming good vacuum gauge reading is almost normal, reading in the manometer is greater	<ol style="list-style-type: none"> <li>1. Discharge obstructed.</li> </ol>	The discharge is clear of obstructions That the discharge valves operate correctly
E) The pump loses its priming during operation, vacuum gauge reading drops to zero.	<ol style="list-style-type: none"> <li>1. Suction dynamic level too high.</li> <li>2. The pump is sucking air.</li> </ol>	When the pump is operating, never lacks water in the suction. For leaks in suction piping, flanges and gaskets. That there is no vortex effect at the end of the suction, this lack of water.
F) The pump priming pumps well and satisfactorily but noisy.	<ol style="list-style-type: none"> <li>1. Pump base is loose.</li> <li>2. Cavitation.</li> <li>3. Bearings.</li> <li>4. Vibration.</li> </ol>	That screws are tight at the base. There are no cracks in the base. The dynamic level is not too high. That the pumping capacity is not too much. The pump is operating in the range of NPSHR. If reducing flow makes the noise gone, then the problem is in the point above; partially close the discharge valve. The bearings for wear. That there is oil in the deposit. The impeller does not have any foreign material. The pump is operating in the range. That the alignment is correct.
F) Motor overload	<ol style="list-style-type: none"> <li>1. Low Voltage.</li> <li>2. Overload</li> </ol>	The voltage is correct. The amperage of the plate is not exceeded. There is no foreign material that may force the impeller. That the motor is suitable for the pump.

**NOTE:** Barmesa Pumps assumes no responsibility for damage or injury due to disassembly in the field. Disassembly of the pumps or supplied accessories other than at Barmesa Pumps or its authorized service centers, automatically voids warranty.

# BARMESA PUMPS FACTORY WARRANTY

Barmesa Pumps warrants that products of our manufacture will be free of defects in material and workmanship under normal use and service for 18 months from date of manufacture or 12 months from installation date whichever occurs first. This warranty gives you specific legal rights, which vary from state to state.

This warranty is a limited warranty, and no warranty related claims of any nature whatsoever shall be made against Barmesa Pumps, until the ultimate consumer or his/her successor notifies us in writing of the defect and delivers the product and/or defective part(s) freight prepaid to our factory or nearest authorized service station as instructed by Barmesa Pumps. THERE SHALL BE NO FURTHER LIABILITY, WHETHER BASED ON WARRANTY, NEGLIGENCE OR OTHERWISE. PRODUCT SHALL BE EITHER REPLACED OR REPAIRED AT THE ELECTION OF BARMESA PUMPS. Guarantees relating to performance specifications provided in addition to the foregoing material and workmanship warranties on a product manufactured by Barmesa Pumps, if any, are subject to possible factory testing. Any additional guarantees, in the nature of certified performance specifications or time frame must be in writing and such writing must be signed by our authorized factory manager at time of order placement and/or at time of quotation. Due to inaccuracies in field testing and should a conflict arises between the results of field testing conducted by or for the user, Barmesa Pumps reserves the right to have the product returned to our factory for additional testing.

This warranty shall not apply when damage is caused by (1) improper installation, (2) improper voltage, (3) lightning, (4) excessive sand or other abrasive material, (5) corrosion build-up due to excessive chemical content or (6) uncontrollable acts of god. Any modification of the original equipment will also void the warranty. We will not be responsible for loss, damage or labor cost due to interruption of service caused by defective pumps, parts or systems. Barmesa Pumps will not accept charges incurred by others without our prior written approval.

This warranty is void if our inspection reveals the product was used in a manner inconsistent with normal industry practice and/or our specific recommendations. The purchaser is responsible for communication of all necessary information regarding the application and use of the product. UNDER NO CIRCUMSTANCES WILL WE BE RESPONSIBLE FOR ANY OTHER DIRECT OR CONSEQUENTIAL DAMAGES, INCLUDING BUT NOT LIMITED TO TRAVEL EXPENSES, CONTRACTOR FEES, UNAUTHORIZED REPAIR SHOP EXPENSES, LOST PROFITS, LOST INCOME, LABOR CHARGES, DELAYS IN PRODUCTION, IDLE PRODUCTION, WHICH DAMAGES ARE CAUSED BY ANY DEFECTS IN MATERIAL AND/OR WORKMANSHIP AND/OR DAMAGE OR DELAYS IN SHIPMENT. THIS WARRANTY IS EXPRESSLY IN LIEU OF ANY OTHER EXPRESS OR IMPLIED WARRANTY. No rights extended under this warranty shall be assigned to any other person, whether by operation of law or otherwise, without our prior written approval.

## IMPORTANT!

If you have a claim under the provision of the warranty, contact Barmesa Pumps or your authorized Barmesa Pumps Distributor:  
warranty@barmesapumps.com  
www.barmesapumps.com



