

Please read and save this Repair Parts Manual. Read this manual and the General Operating Instructions carefully before attempting to assemble, install, operate or maintain the product described. Protect yourself and others by observing all safety information. The Safety Instructions are contained in the General Operating Instructions. Failure to comply with the safety instructions accompanying this product could result in personal injury and/or property damage! Retain instructions for future reference. AMT reserves the right to discontinue any model or change specifications at any time without incurring any obligation.

©2017 AMT Pump Company, A Subsidiary of The Gorman-Rupp Company, All Rights Reserved.

Periodic maintenance and inspection is required on all pumps to ensure proper operation. Unit must be clear of debris and sediment. Inspect for leaks and loose bolts. Failure to do so voids warranty.

# Submersible Contractor Pumps



Refer to pump manual 1808-636-00 for General Operating and Safety Instructions.

## DESCRIPTION

These versatile centrifugal Submersible Contractor pumps are intended for use in residential, commercial and industrial settings. Examples for usage include: construction sites, waste water, storm water, farming, mines, marine, basement and other general drainage applications involving sediment laden liquids with small solids. Submersible design means low noise and no priming issues. Each unit is completely assembled and includes a self-cleaning, semi-open impeller featuring abrasion-resistant high chromium steel construction for durability. Pumps incorporate a mechanical shaft seal with long lasting silicon carbide wear faces and feature a secondary shaft seal and oil chamber. Pumps have a 3450 RPM electric motor fitted with an unfinished power cord that requires field wiring (no controls are supplied). Motors are rated continuous duty and single phase units have automatic restart thermal overload protection. Handle liquids from 40° to 104° F (4° to 40° C). For use with non-flammable liquids compatible with pump component materials.

## PRE-INSTALLATION INSPECTION

1. Check the pump for damage that may have occurred during shipping.
2. Inspect the pump for any cracks, dents, damaged threads, etc.
3. Check power cable for any cuts or damage.
4. Check for and tighten any hardware that appears loose.
5. Carefully read all tags, decals and markings on the pump.

**IMPORTANT:** Always verify that the pump nameplate, amps, voltage, phase and HP rating match your control panel and power supply. Installation and connection must be performed by a qualified electrician. *Warranty does not cover damage by connecting pumps and controls to an incorrect power source (voltage/phase supply).*

6. Keep the invoice and shipping documents with the instruction manual for future reference.
7. Contact the distributor from which the pump was purchased for questions.

## RECOMMENDED NON-OPERATING STORAGE

### Storage Environment

- The storage environment must be between 40° to 104° F (4° to 40° C). DO NOT allow the pump to freeze; this voids all warranty.
- The pump must be stored in a dry and secure location in the upright position. Avoid direct sunlight and maintain a temperature below 104° F.

### For Storage Periods of 3 years or Less

- Disconnect from power source and rotate the impeller shaft by hand every 6 months and again prior to start up.
  - Keeps seal faces from sticking and failure on start up.
  - Keeps bearing grease from settling and failing on start up.
- For pumps with oil in motor shell; check for oil leaks and oil in seal chambers prior to startup to ensure proper oil level is moisture free and has not broken down.

AMT Submersible Shredder Sewage & Contractor pumps operate at 3450 RPM unlike grinder type submersible pumps that operate at 1725 RPM and therefore include a suction strainer with various sized slots and holes based on each type of pump to protect the pump from seizing or binding the impeller and motor caused by excess, oversized or stringing type trash, leaves, sticks,

waster, etc. that may clog and/or bind the pump impeller/motor causing motor failure. Removal of the strainer voids all warranty. Minimum liquid height per the respective pump model specification sheet must be maintained to avoid damage to the pump or pump motor. Reference [www.amtpump.com](http://www.amtpump.com) for current specification sheet.

## MAINTENANCE

### ▲ WARNING

**Make certain that unit is disconnected from power source before attempting to service or remove any components!**

## POWER CORD REPLACEMENT

Periodically inspect power cord and replace whenever abrasion, cracking, softening or other signs of deterioration are found.

Refer to Figures 1 and 2.

1. Place unit on workbench in upright position.
2. Remove two fasteners (Ref. No. 39) that hold outer cord retainer (Ref. No. 38).
3. Remove fasteners(s) (Ref. No. 5) at handle (Ref. NO. 6) to free wire loom (Ref. No. 2).
4. Remove three fasteners (Ref. No. 36) to detach handle and outer shell (Ref. No. 37). Shell can now be slid off towards top of pump.
5. Clean dirt and rust from around wire cover (Ref. No. 7).
6. Remove two fasteners (Ref. No. 4) that hold inner cord retainer (Ref. No. 3).
7. Remove four fasteners (Ref. No. 10) holding wire cover in place.
8. Carefully pry cover from unit with screwdriver.

**IMPORTANT:** Be careful to keep rust and other debris from falling into motor housing during cover removal.

9. Take note of proper wire configuration and connect new power cord (Ref. No. 1) in identical fashion.

### ▲ WARNING

**If unsure about above information or wiring diagrams, consult an electrician familiar with motor wiring.**

# Submersible Contractor Pumps

- Clean sealing flanges if necessary and reassemble pump in reverse order.

## IMPELLER INSPECTION /REPLACEMENT

If pump develops poor performance characteristics, impeller may be worn or clogged.

### IMPELLER INSPECTION

Refer to Figure 2

- Place unit on workbench in upright position and clean rust and buildup from around pump-to-motor flange.
- Remove four short fasteners (Ref. No. 15), which attach base (Ref. No. 30) to unit.
- Lift motor assembly up out of pump assembly and lay on workbench in horizontal position. Rap down on pump body with soft mallet, if necessary, to separate parts.
- Inspect impeller (Ref. No. 26). If clog is found, remove debris and reassemble in reverse order. If damage to impeller is found, such as pitting, deep grooves, or breakage, proceed to next section.

### IMPELLER REPLACEMENT

- Remove impeller fastener (Ref. No. 28) by unscrewing in counterclockwise direction.

**NOTE:** To prevent motor shaft from turning, wedge a screwdriver between impeller vane and impeller fastener (see Figure 1).

- Slide off impeller washer (Ref. No. 27). Impeller is keyed to motor shaft and can now be pulled free.
- Install replacement impeller and reassemble in reverse order.

### MECHANICAL SEAL REPLACEMENT

Motor internals are protected from contact with liquid being pumped by a mechanical shaft seal and oil cavity. When seal wears out, potential motor life will be compromised. Therefore, periodic seal replacement is recommended. Time interval between replacements will depend on abrasiveness of liquid being pumped, temperature, total accumulated runtime, etc.

**IMPORTANT:** Always replace seal head (Ref. No. 18) and both seal seats (Ref. Nos. 17 & 19) at same time to ensure proper mating of components.

Refer to Figure 2

- Disassemble pump by following directions in both "Power Cord Replacement" and "Impeller Inspection / Replacement" sections.
- With unit on its side and wire cover, pump assembly and impeller removed, lift shaft key (Ref. No. 13) from shaft/rotor (Ref. No. 12) using a pliers.
- Clean rust and buildup from unit.
- From top of unit, remove four long fasteners (Ref. No. 10), which attach lower end bell (Ref. No. 16) to motor case (Ref. No. 11).
- Rap on ears of lower end bell with a soft mallet to break it free from motor case. Next, carefully guide lower end bell along with shaft/rotor and bearing assembly out of motor case.
- Drain oil from seal cavity by removing drain screw (Ref. No. 23) and seal (Ref. No. 22) from seal plate (Ref. No. 21). Then tip components upright overtop of a catch pan until oil is drained.

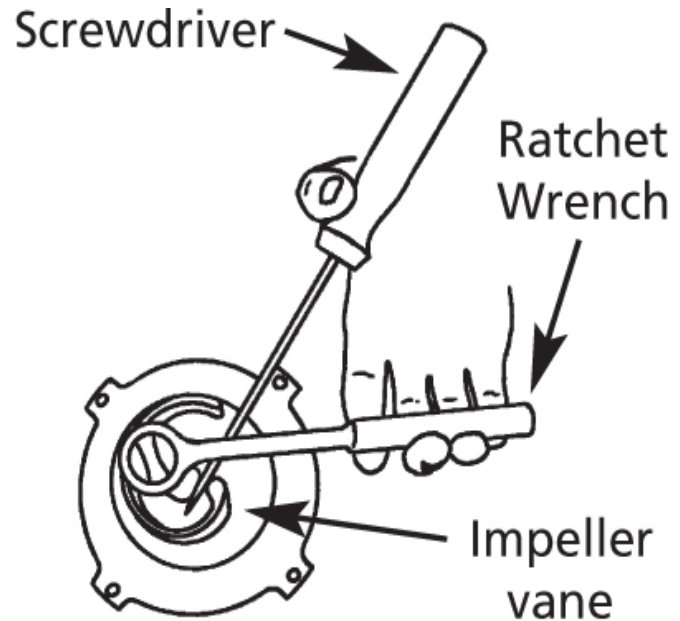

Figure 1 - Impeller Removal

- Remove three fasteners (Ref. No. 25) and pry out seal plate with screwdriver. Slinger washer (Ref. No. 24) will come free at this time.
- Use a press or gear puller to remove shaft and bearings from lower end bell. Shaft seal head will now be free.

**IMPORTANT:** Shaft seal head (with spring) has unique ends and the two seal seats are different from one another (**Be sure to note size and color of each before disassembly so that new parts are installed in proper orientation.**)

- Remove upper seal seat (Ref. No. 17) from lower end bell by using a screwdriver or dowel to press on seal from rear. Do the same for lower seal seat (Ref. No. 19) in seal plate.
- Clean seal seat cavities before inserting new seals.
- Carefully wipe polished surface of new seal seats with a clean cloth.
- Wet outside of rubber portion of seal seats with a light coating of soapy water.
- Press each new seal seat squarely into cavity in both seal plate and lower end bell. If seal seat does not press squarely into cavity, it can be adjusted into place by pushing on it carefully with a piece of pipe or dowel. Always use a piece of cardboard between pipe and seal seat to avoid scratching seal seat. (This is a lapped surface and must be handled very carefully.)
- After each seal seat is in place, be sure that it is clean and has not been marred.
- Using a clean cloth, wipe shaft and make certain that it is perfectly clean.
- Carefully guide motor shaft through seal seat and use a press to seat bearing back into lower end bell.
- Apply a light coating of soapy water to inside rubber portion of seal head and slide onto shaft (be sure to start correct end first).
- Place seal plate back onto lower end bell being careful to guide shaft and avoid damage to seal seat. Secure with fasteners.
- Press slinger washer back in place.
- Refill cavity with oil through fill hole and reassemble in reverse order.

# Submersible Contractor Pumps

**For Repair Parts contact dealer where pump was purchased.**

Please provide following information:

-Model Number

-Serial Number (if any)

Part description and number as shown in parts list

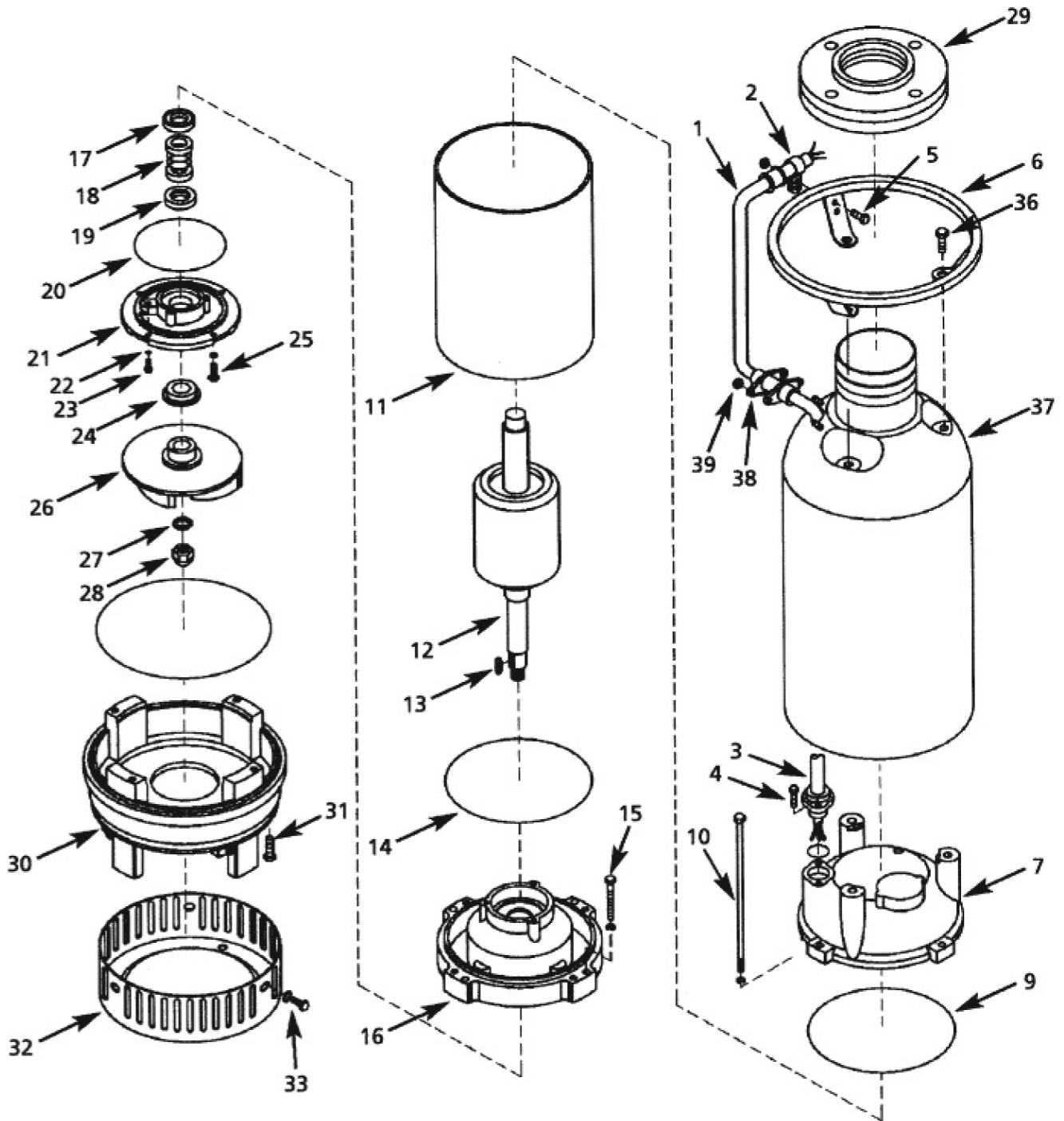

Figure 2 - Repair Parts Illustrations

**Repair Parts List**

Ref No.	Description	Part Number for Models					Qty
		2-inch - 1HP	2-inch - 2HP	3-inch - 3HP	3-inch - 5HP	4-inch - 7-1/2HP	
		5770-95 5771-95	5773-95	5777-95	577A-95 577B-95	577D-95 577E-95	
1	Power Cord Kit - 115VAC Models	5770-350-90	-	-	-	-	1
	Power Cord Kit - 230VAC Models	5771-350-90	5773-350-90	5777-350-90	577A-350-90	577D-350-90	1
	Power Cord Kit - 460VAC Models (includes Ref. Nos. 1, 2, 3, and 4)	-	-	-	577B-350-90	577E-350-90	1
2	Wire Loom	Incl. w/ Ref. 1	Incl. w/ Ref. 1	Incl. w/ Ref. 1	Incl. w/ Ref. 1	Incl. w/ Ref. 1	1
3	Retainer	Incl. w/ Ref. 1	Incl. w/ Ref. 1	Incl. w/ Ref. 1	Incl. w/ Ref. 1	Incl. w/ Ref. 1	1
4	Fastener	Incl. w/ Ref. 1	Incl. w/ Ref. 1	Incl. w/ Ref. 1	Incl. w/ Ref. 1	Incl. w/ Ref. 1	2
5	Fastener	*	*	*	*	*	2
6	Handle Kit	5771-100-90	5773-100-90	5777-100-90	577A-100-90	577D-100-90	1
7	Wire Cover	-	-	-	-	-	-
8	Fastener	*	*	*	*	*	4
9	Seal	Incl. w/ Ref. 35	Incl. w/ Ref. 35	Incl. w/ Ref. 35	Incl. w/ Ref. 35	Incl. w/ Ref. 35	1
10	Fastener	-	-	-	-	-	-
11	Motor Case	-	-	-	-	-	-
12	Shaft/Rotor	-	-	-	-	-	-
13	Shaft Key	-	-	-	-	-	-
14	Seal	Incl. w/ Ref. 35	Incl. w/ Ref. 35	Incl. w/ Ref. 35	Incl. w/ Ref. 35	Incl. w/ Ref. 35	1
15	Fastener	*	*	*	*	*	4
16	Lower End Bell	-	-	-	-	-	-
17	Upper Seal Seat	Incl. w/ Ref. 35	Incl. w/ Ref. 35	Incl. w/ Ref. 35	Incl. w/ Ref. 35	Incl. w/ Ref. 35	1
18	Seal Head	Incl. w/ Ref. 35	Incl. w/ Ref. 35	Incl. w/ Ref. 35	Incl. w/ Ref. 35	Incl. w/ Ref. 35	1
19	Lower Seal Seat	Incl. w/ Ref. 35	Incl. w/ Ref. 35	Incl. w/ Ref. 35	Incl. w/ Ref. 35	Incl. w/ Ref. 35	1
20	Seal	Incl. w/ Ref. 35	Incl. w/ Ref. 35	Incl. w/ Ref. 35	Incl. w/ Ref. 35	Incl. w/ Ref. 35	1
21	Seal Plate	-	-	-	-	-	-
22	Seal	Incl. w/ Ref. 35	Incl. w/ Ref. 35	Incl. w/ Ref. 35	Incl. w/ Ref. 35	Incl. w/ Ref. 35	1
23	Drain Plug	*	*	*	*	*	1
24	Slinger Washer	Incl. w/ Ref. 35	Incl. w/ Ref. 35	Incl. w/ Ref. 35	Incl. w/ Ref. 35	Incl. w/ Ref. 35	1
25	Fastener	*	*	*	*	*	4
26	Impeller	Incl. w/ Ref. 34	Incl. w/ Ref. 34	Incl. w/ Ref. 34	Incl. w/ Ref. 34	Incl. w/ Ref. 34	1
27	Impeller Washer	Incl. w/ Ref. 34	Incl. w/ Ref. 34	Incl. w/ Ref. 34	Incl. w/ Ref. 34	Incl. w/ Ref. 34	1
28	Impeller Fastener	Incl. w/ Ref. 34	Incl. w/ Ref. 34	Incl. w/ Ref. 34	Incl. w/ Ref. 34	Incl. w/ Ref. 34	1
29	Flange Kit	-	-	5777-001-90	577A-001-90	577D-001-90	1
30	Base Kit (includes Ref. No. 30 and 31)	5771-150-90	5773-150-90	5777-150-90	577A-150-90	577D-150-90	1
31	Fastener	Incl. w/ Ref. 30	Incl. w/ Ref. 30	Incl. w/ Ref. 30	Incl. w/ Ref. 30	Incl. w/ Ref. 30	4
32	Strainer Kit	5771-170-90	5773-170-90	5777-170-90	577A-170-90	577D-170-90	1
33	Fastener	*	*	*	*	*	3
34	Impeller Kit (includes Ref. Nos. 26, 27, 28 and 34)	5771-010-90	5773-010-90	5777-010-90	577A-010-90	577D-010-90	1
35	Seal Kit (not shown) (includes Ref. Nos. 9, 14, 17, 18, 19, 20, 22, and 24)	5771-300-90	5773-300-90	5777-300-90	577A-300-90	577D-300-90	1
36	Fastener	*	*	*	*	*	3
37	Outer Shell	-	-	-	-	-	-
38	Outer Retainer	-	-	-	-	-	-
39	Fastener	*	*	*	*	*	2
40	Start Capacitor	5761-351-00	5763-351-00	5763-351-00	-	-	1
41	Run Capacitor	-	5761-351-00	5761-351-00	-	-	1

(-) Not Available

(\*) Standard Hardware Item, Available Locally







AMT Pump Company  
(herein "AMT")  
400 Spring Street  
Royersford, PA 19468  
Phone: (610) 948-3800  
Fax: (610) 948-5300  
www.amtpump.com

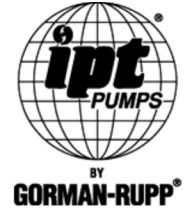

## General Information

**SALES POLICY:** AMT products are sold through our established Distributors. We do not sell direct to the consumer or organization not entitled to trade recognition. Therefore, possession of our catalogs and/or price list(s) does not infer an offer to sell.

**MINIMUM ORDER:** We appreciate your order, however, all orders are subject to a minimum \$35.00 net invoice charge (excluding freight). This applies to all pump and parts purchase orders.

**PRICES:** Prices are subject to change without notice. All orders accepted are subject to prices in effect at time of shipment.

**PAYMENT TERMS:** Terms, upon establishment of credit, are Net 30 days. Past due accounts may be subject to a service charge of 1.5% per month. Domestic or assignable letter of credit is required for all export trade.

**PAST DUE ACCOUNTS:** AMT reserves the right to withhold open account shipments on any past due account. Invoices are considered past due after thirty (30) days. In the interest of sound business, all orders are subject to approval of the Credit Department.

**SHIPPING INSTRUCTIONS:** All shipments will be made F.O.B. the factory. Where instructions for shipment do not appear on the order, the shipment will be made according to our best judgment. Full risk of loss (including transportation delays and losses) shall pass to the customer upon delivery of the products to the carrier at the F.O.B. point. When loss or delay occurs, primary responsibility for tracing rests with the customer. When there is LOSS or APPARENT VISIBLE DAMAGE to a shipment, when tendered for delivery, **DO NOT** give the carrier a clear receipt. Note such damage on the carrier's delivery receipt and **HAVE THE DRIVER SIGN THE RECEIPT.**

**PRODUCT REVISIONS:** AMT reserves the right to discontinue, change or improve its products or any portions thereof without being obligated to provide such a change or improvement for units sold and/or shipped prior to such a change or improvement.

**LEAD TIME:** Products designated "Quick Ship Product", also referred to as "QSP" will normally be shipped within 24 hours of receipt of a non-cancellable purchase order. Only limited quantities of "QSP" pumps are available.

**STANDARD LEAD TIME:** Lead time is two weeks for all non "QSP" product. AMT reserves the right to revise lead times as required due to availability of materials and all other causes beyond our control.

**VIP SHIPMENT:** Select AMT and IPT branded pumps are available for next day shipment for non-QSP (Quick Ship Products) items and subjected to a specific model surcharge per unit noted in the respective price book. Requires calling for availability, confirmation and a non-cancellable purchase order or credit card payment prior to shipment. The expedited shipping charges are an additional cost added separately from the VIP charges per item. AMT reserves the right to revise lead times as required due to availability of materials and all other causes beyond our control. QSP quantities are limited as determined by AMT.

ALL purchase orders must be submitted via hard copy sent to AMT customer service department by fax, EDI or e-mail.

**RETURN GOODS POLICY:** Goods shall not be returned without a return goods authorization number (RGA) issued by AMT customer service. The RGA number must be listed on the packing list. Only current model and part numbers with a valid date code may be returned (within one year from date of purchase). **A 20% restocking and packaging charge will apply to all returns. All shipping charges must be pre-paid. No exceptions.**

**ORDER CHANGES BY CUSTOMER:** Orders in process may not be changed except with written consent and may be subject to special charges.

## 12 Month Limited Warranty

### EXTENT AND DURATION OF LIMITED WARRANTY

**Coverage:** AMT Pump Company (herein "AMT") or IPT Pumps by Gorman-Rupp (herein "IPT") or Gorman-Rupp Industries Division of The Gorman-Rupp Company, Patterson, or the Gorman-Rupp Company (herein referred to as "G-R Unit") each individually warrants that its products and parts shall be free from defects in material and workmanship for twelve (12) months from the date of purchase by the original end user when installation is made and maintenance is performed in accordance with G-R Unit's recommendations. Wear and tear resulting from use and items normally consumed in use are not covered.

### EXCEPTIONS

( A ) This Limited Warranty shall not apply to mechanical seals in AMT or IPT pumps and the following products and parts: engines, motors, trade accessories and all other products, components, parts and materials not manufactured by the G-R Units. These items may, however, be covered by the warranties of their respective manufacturers. ( B ) This warranty does not extend to or apply to any unit which has been repaired or altered at any place other than by a G-R Unit, or by persons not expressly approved by a G-R Unit to make repairs or alterations, nor to any unit the serial number, model number or identification of which has been removed, defaced or altered. ( C ) This warranty does not extend to any product manufactured by a G-R Unit, which has been subjected to mis-use, neglect, accident, improper installation, or use in violation of instructions furnished by a G-R Unit. ( D ) Pump Kits: This warranty does not extend to any product sold by a G-R Unit unassembled as a Pump Kit. Pump Kits are warranted against defects in material and workmanship for 60 days from the date of shipment from a G-R Unit. Any Pump Kit parts deemed defective by a G-R Unit will be replaced free of charge within 60 days of shipment. Pump Kits are not returnable for credit.

### LIMITATIONS

**THE G-R UNITS' SOLE AND EXCLUSIVE WARRANTY WITH RESPECT TO THEIR PRODUCTS AND PARTS IS THIS LIMITED WARRANTY. THIS LIMITED WARRANTY IS IN LIEU OF ALL OTHER EXPRESS AND/OR IMPLIED WARRANTIES, INCLUDING IMPLIED WARRANTIES OF MERCHANTABILITY AND FITNESS FOR PARTICULAR PURPOSE.**

### EXCLUSIVE REMEDY AND DAMAGES

The sole and exclusive remedy for breach of this Warranty by a G-R Unit and the entire extent of its liability for such breach or for damages arising from the use of the products and parts covered under this Limited Warranty, shall be as follows:

- Repair or Replacement:** If inspection shows that any G-R Unit product or part covered under this Limited Warranty is defective in materials or workmanship, the G-R Unit shall repair or replace the defective or non-conforming product or part without charge, whichever the G-R Unit chooses. You must have properly maintained and used the product or part claimed to be defective in accordance with the maintenance schedule or manual, which comes with the product. No allowance will be made for labor, installation, removal, transportation or other charges incurred by you in connection with such repair or replacement.
- To obtain the above remedy:
  - Immediately notify the G-R Unit upon discovery of the claimed defect in materials or workmanship and provide the serial number or date code of the product and/or part(s) or provide the G-R Unit with the invoice or bill of sale referencing the product by no later than the expiration date of the warranty period.
  - The G-R Unit will advise whether inspection will be necessary and how whether repair or replacement will be made. If inspection by the G-R Unit is necessary, the pump or defective part must be sent freight pre-paid to the G-R Unit. Return shipment will be F.O.B. the G-R Unit's plant.
  - Return Goods Authorization Requirement:** No product will be accepted for return or replacement without the prior written authorization of the G-R Unit. Upon such authorization, and in accordance with instructions from the G-R Unit, the product will be returned to the G-R Unit, shipping charges prepaid by the Buyer.
- Damages:** The G-R Unit's liability for damages for breach of this Limited Warranty shall not exceed the amount of the purchase price of the product or part(s) in respect to which Such damages are claimed. **IN NO EVENT SHALL THE G-R UNITS BE LIABLE FOR INCIDENTAL, CONSEQUENTIAL OR SPECIAL DAMAGES FOR BREACH OF THIS LIMITED WARRANTY.**

Some states do not allow the exclusion or limitation of incidental or consequential damages, so the above limitation or exclusion may not apply to you. This Limited Warranty gives you specific legal rights, and you may also have other rights, which vary from state to state.



**A Gorman-Rupp Company**



BY  
**GORMAN-RUPP®**

[www.amtpump.com](http://www.amtpump.com)