

# Submersible Utility Sump Pumps

## 5010-99

- **Heavy Duty Corrosion Resistant Stainless Steel Housing with Plastic Internals**
- **1-1/4" NPT Discharge with Adaptor**
- **Automatic Tethered Float Switch Included**
- **3/4 HP, 115VAC UL Cord with 3 Prong Plug**
- **Thermal Overload Protection**
- **Garden Hose Adapter Included**

## 5000-95

- **Heavy Duty Corrosion Resistant Stainless Steel Housing with Cast Iron Internals**
- **Automatic Vertical Float Switch Included**
- **2/5 HP, 115VAC UL Cord with 3 Prong Plug**
- **Thermal Overload Protection**
- **Oil Chamber Design with Ball Bearing and Secondary Shaft Seal for Long Life**



Model 5000-95

Model 5010-99

The AMT Submersible Drainage / Sump Pumps are lightweight submersible pumps with built-in float switches. These submersibles are intended for use in residential, commercial and industrial settings. Examples include, but not limited to: basements, boats, tanks and other general drainage applications involving dirty water. Each unit is completely assembled and features a self-cleaning semi-open impeller and automatic on/off float switch. All pumps incorporate a mechanical shaft seal with carbon and ceramic wear faces. These pumps feature corrosion-resistant stainless steel outer bodies for longevity, with either cast iron or plastic internals. Pumps have a 3450 RPM electric motor fitted with a finished 3-prong grounding type power cord. Motors are UL Listed and rated continuous duty and have automatic restart thermal overload protection.

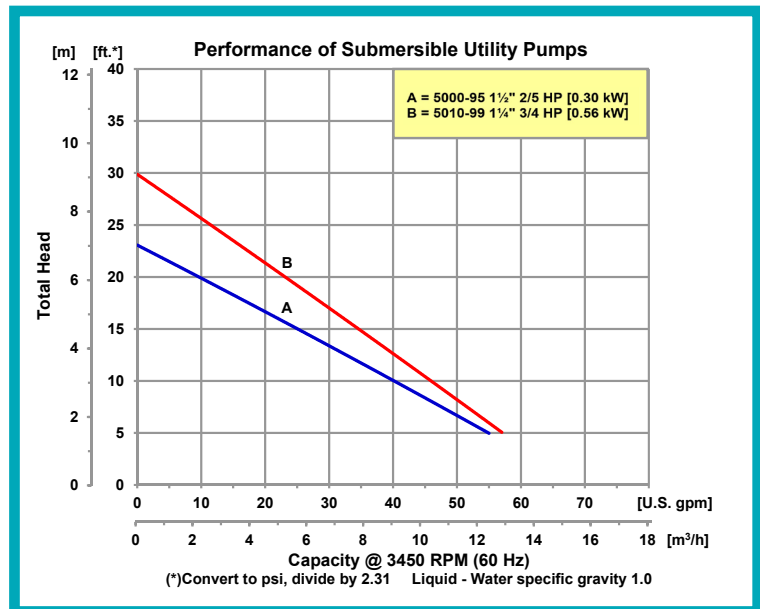

400 Spring Street • Royersford, PA 19468 USA

[www.amtpump.com](http://www.amtpump.com) • 888-amt-pump (268-7867)

For use with nonflammable liquids compatible with pump component materials. Viton® and Teflon® are registered trademarks of E. I. DuPont.

## Pump Dimensional & Specification Data

Model	Curve	HP	VAC	FLA	DIS* (FNPT)	Basic Construction	Float Switch Type	Max Solids (Dia.)	Cord Length (Ft.)	Ship Wt. (Lbs.)
5010-99	B	3/4	115	7	1¼	Stainless Steel/Plastic	Tethered	1/5"	25' w/plug	15
5000-95	A	2/5	115	4	1½	Stainless Steel/Cast Iron	Vertical	1/5"	25' w/plug	24

(\*) Standard NPT (Female) pipe thread in inches.

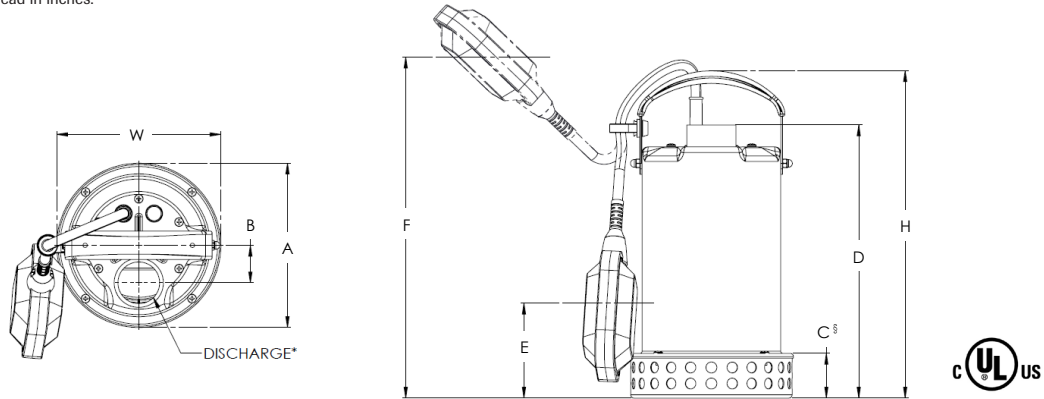

Model	A	B	C §	D	E	F	W	H
5010-99	59. [15.0]	1.4 [3.4]	1.6 [4.1]	9.8 [24.9]	3.4 [8.7]	12.3 [31.1]	5.9 [15.0]	11.8 [29.9]

NOTE: Dimensions are in inches (centimeters) and have a tolerance of ± 1/8".

§) Minimum Liquid Height.

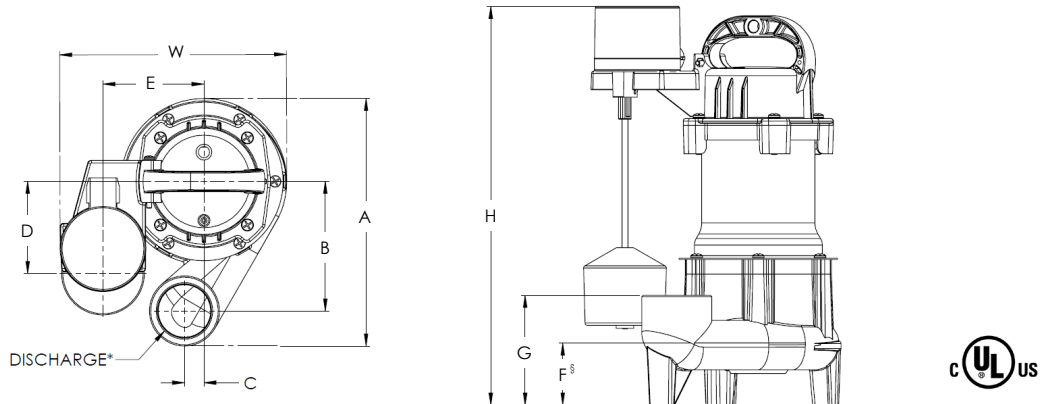

Model	A	B	C	D	E	F §	G	W	H
5000-95	8.0 [20.3]	4.2 [10.6]	0.6 [1.6]	3.0 [7.5]	3.3 [8.3]	2.0 [5.1]	3.5 [9.0]	7.3 [18.6]	12.9 [32.7]

NOTE: Dimensions are in inches (centimeters) and have a tolerance of ± 1/8".

§) Minimum Liquid Height.

## Standard Features

### Model # 5010-99

- Stainless Steel Housing with Plastic Internals
- Automatic On-Off Tethered Float Switch Design
- 1-1/4" NPT Discharge w/ Adaptor Included
- Built-In Bottom Suction Screen Allows 1/5" Solids
- Easy Installation, Includes 25' Power Cord
- Maximum Temp 104° F (40° C)
- Built-In Carry Handle
- UL Listed

### Model # 5010-95

- Stainless Steel Housing with Cast Iron Construction
- Automatic On-Off Vertical Float Switch Design
- 1-1/2" NPT Discharge
- Double Mechanical Seal Construction
- Easy Installation, Includes 25' Power Cord
- Maximum Temp 104° F (40° C)
- Built-In Carry Handle
- UL listed