

Please read and save this Repair Parts Manual. Read this manual and the General Operating Instructions carefully before attempting to assemble, install, operate or maintain the product described. Protect yourself and others by observing all safety information. The Safety Instructions are contained in the General Operating Instructions. Failure to comply with the safety instructions accompanying this product could result in personal injury and/or property damage! Retain instructions for future reference. AMT reserves the right to discontinue any model or change specifications at any time without incurring any obligation.

©2012 American Machine & Tool Co., Inc. of PA, A Subsidiary of The Gorman-Rupp Company, All Rights Reserved.

Periodic maintenance and inspection is required on all pumps to ensure proper operation. Unit must be clear of debris and sediment. Inspect for leaks and loose bolts. Failure to do so voids warranty.

1750 RPM Centrifugal Pumps



Refer to pump manual 1808-634-00 for General Operating and Safety Instructions.

DESCRIPTION

These non-self-priming centrifugal pumps are intended for liquid transfer, heating and cooling circulation, booster service and other industrial applications where no suction lift is required.

This manual covers the installation, operation and maintenance of AMT 1750 RPM centrifugal pumps. These pumps are a centrifugal, single stage; single suction type furnished with mechanical seals. When properly installed and when given reasonable care and maintenance, centrifugal pumps should operate satisfactorily for a long period of time. Centrifugal pumps use the centrifugal force principal of accelerating the liquid within a rotating impeller, and then collecting it and converting it to pressure head in a stationary volute.

The back pullout design allows for removal of the motor and integral rotating element without disturbing the suction and discharge piping. The suction and discharge nozzles are drilled and tapped for gauge connections. Pump casings are drilled and tapped for complete pump drain. Casing wear rings are provided as standard equipment.

These are manual units, no controls are supplied. For use with nonflammable, non-abrasive liquids compatible with pump component materials.

STORAGE & PROTECTION

All pumps are shop serviced and ready for operation when delivered, but there are occasions when considerable time elapses between the delivery date and the time the pump is put into operation. Equipment, which is not in service should be kept in a clean, dry area. If equipment is to be stored for long periods of time (six months or more), the following precautions should be taken to ensure that the equipment remains in good condition:

1. Be sure that the motor bearings are lubricated, if required.
2. Unpainted-machined surfaces, which are subject to corrosion, should be protected by some corrosive resistant coating.
3. The shaft should be rotated 10 to 15 revolutions by hand periodically in order to spread the lubricant over all the bearing surfaces. Suitable intervals are from one to three months, depending on atmospheric conditions, etc. In order to ensure that the pump shaft does not begin to sag, do not leave the shaft in the same position each time.
4. Space heaters on motors and controllers should be connected and fully operable if atmospheric conditions approach those experienced in operation. Consult instruction manuals for other precautions concerning storage of individual components of pumping unit.
5. Fresh lubricant should be applied to bearings upon removal of equipment from storage, if required.

INSTALLATION

Location:

Several factors should be considered when selecting a location for the pumping unit (pump and drive). The unit should be accessible for both inspection and maintenance. Headroom should be provided for the use of crane, hoist or other necessary lifting devices. The pump should be located as close as possible to the liquid supply so that the suction line is short and direct. Location should require a minimum of elbows and fittings in the discharge line to minimize friction losses. The unit should be protected against flooding.

Mounting:

Pumps can be mounted on steel bases, raised concrete pads or floor as long as the mounting surface is level. The mounting surface must be solid and rigid enough to support the pump unit without deflection or vibration. To facilitate the leveling of the pump, use a spirit level and short pieces of pipe in the threaded nozzles to determine if the pump is level in all directions.

Wiring and Controls:

The electric motor power supply connections must conform to national and local codes. The motor ratings stamped on the motor nameplate must match the line voltage and wire capacity.

▲ WARNING

DO NOT USE ANY OTHER VOLTAGE EXCEPT WHAT IS ON THE MOTOR NAMEPLATE!

Flooded Suction:

Net Positive Suction Head Required (NPSHR). Curve with NPSHR available at www.amtpump.com.

1. Problems will arise in operation of this pump unless the recommended NPSHR is supplied to the pump (See "Troubleshooting" chart in 1808-634-00 manual).
2. Salt Water Usage: Because of crystallization and erosive material on the shaft seal pump requires fresh water rinse to avoid premature failure.
3. Liquid must be added to pump before initial starting.

OPERATION

▲ CAUTION

Do not exceed the rated working pressure of the pump. The sum of the suction pressure and the maximum pump operating head (converted to units of pressure) must be less than the pump working pressure, at all times.

▲ CAUTION

Do not exceed the pressure capabilities of the mechanical seals. The maximum pressure on the mechanical seal for this pump type is equal to the suction pressure plus 10% of the maximum pump operating head (converted to units of pressure) for a new pump. For a pump with worn internal ring clearance, the maximum pressure on the mechanical seal is equal to the suction pressure plus 15% of the maximum pump operating head (converted to units of pressure). This pressure must not exceed the rated working pressure of the mechanical seals.

1750 RPM Centrifugal Pumps

Starting:

- When possible, turn the pump shaft by hand to ensure that the parts do not bind.
- Open the valve in the pump suction line, if fitted.
- Close discharge valve.
- Prime the pump as follows before operating:
The pump operates under positive pressure, open vent valve on top of the pump casing. After all entrained air has escaped, close the vent valves. Rotate the shaft, if possible, to allow any air trapped in the impeller passages to escape.
- Check direction of rotation before starting pump. Rotation should be the same as the direction arrow on the case.

▲ CAUTION

Do not operate without liquid. Pump seals depend on the liquid being pumped for lubrication. Make sure pump is primed and that no air is in the suction piping and the pump case. Make sure all valves are open or closed as required by your specific requirements.

Start driver:

- Open discharge valve slowly when the pump is up to speed.

▲ CAUTION

Overheating and/or loss of prime will result if the pump is operated against a closed valve for more than a few minutes.

NOTE: Should the pump fail to build up pressure or discharge water when the discharge valve is opened, stop the pump and read **Section Locating Operating Difficulties**.

Shutdown:

The pump may be stopped with the discharge valve open without causing damage. However, in order to prevent water hammer effects, as a general recommendation the discharge valve should be closed first.

1. Close discharge valve.
2. Stop driver.
3. If danger of freezing exists, isolate the pump by closing a valve in the pump suction line, if fitted, and drain the pump completely.

REPAIRS AND REPLACEMENT

▲ CAUTION

INSTALLATION OF NEW SEAL *The precision lapped faces on shaft seal are easily damaged. Handle your replacement seal carefully.*

To Remove Impeller:

Reference: Pump Assembly Section

1. Remove bolts holding the motor (7) to base or floor.
2. Remove bolts holding the volute cover (5) to the casing (1).
3. Pull entire rotating assembly and volute cover (5) from the casing (1). The assembly should be pulled straight out until impeller (2) is clear of the casing.

Disassembly of Rotating Element:

1. Remove the impeller screw (9) and impeller washer (8).
2. Remove impeller (2). Do not loosen impeller key (10).
3. Remove bolts from between volute cover (5) and motor (7).
4. Remove volute cover (5).
5. Remove mechanical seal (12) and shaft sleeve (6) with O-ring.
6. Remove deflector (1).

Cleaning:

▲ WARNING

Petroleum based cleaning solvents are flammable. Smoking or open flames in the vicinity of these solvents is extremely hazardous and must not be permitted. Disregarding this warning could result in grave personal injury.

Clean all metal parts with a solvent. Use a bristle brush (not metal or wire) to remove tightly adhering deposits. A fiber scraper may be used to remove the gasket and shellac from casing flange. Blow dry with clean dry compressed air.

▲ CAUTION

Never use hydrocarbon liquids (oil or solvent) to clean mechanical seal parts. Use of oil or solvent will deteriorate material used on the seal. Use mild soap solution to clean seal parts. Use only your finger to remove dirt. Rinse with clean water and dry with mild air stream. Use care not to damage or scratch lapped surfaces.

Inspection:

Visually inspect parts for damage affecting serviceability. Check O-rings and gaskets for cracks, nicks or tears; packing rings for excessive compression, fraying or shredding and embedded particles. Replace if defective in any way. Mount shaft between lathe centers and check eccentricity for entire length of the shaft. Eccentricity should not exceed .002 inches (0.05 mm). Bearing surfaces should be smooth; shoulders square and free of nicks.

Measure OD of impeller hub and ID of pump casing. Compute diametrical clearance (ID minus OD) and compare with the original pump specifications. Surfaces must be smooth and concentric. Examine impeller passages for cracks, dents or embedded material. Examine shaft sleeves for wear.

Seal Replacement and Assembly:

The following should prove helpful in reassembling the pump:

1. All parts, inside and out, should be clean. Dirt and grit will cause excessive wear, plus needless shutdown.
2. Install the deflector (11) onto the motor shaft (3).
3. Press the mechanical seal (12) into the volute cover (5).
4. Install the volute cover (5) onto the motor (7).
5. Lubricate the O.D. of the shaft sleeve (6) and the I.D. of the opposite half of the mechanical seal using **International Products P-80 Emulsion Temporary Assembly Lubricant** or equivalent (available from International Products Corporation, 201 Connecticut Drive, Burlington NJ 08016 USA, phone 609-386-8770, Fax 609-386-8438, <http://www.ipcol.com>, mkt@ipcol.com) or equivalent. Press the shaft sleeve (6) through the seal. Coat the interior of the shaft sleeve (6) with **Dow Corning 732 Multi Purpose Sealant** or equivalent.
6. Press the shaft sleeve (6) onto the shaft (3) and install seal spring.
7. Insert the impeller key (10) into the shaft (3) keyway. Install the impeller (2) onto the shaft (3).
8. Coat the impeller bolt (9) with **Loctite 262 Threadlocker** or equivalent. Install the impeller washer (8) and bolt (9).
9. Install the casing ring (4) into the casing (1).
10. Install the gasket (13) and position the rotating assembly into the casing (1).
11. Install and tighten casing bolts.
12. Install all NPT fittings and tubing.
13. Rotate by hand when possible to ensure that the parts do not bind.

1750 RPM Centrifugal Pumps

General Pump Inspection and Maintenance Schedule

HVES-CC Pumps

Excludes drivers, VFD's and controls

Inspect (✓) or Service (•)	Routinely	Monthly	2000 hours or 3 months	4000 hours or 6 months	8000 hours or 12 months
Unusual Noise	✓				
Unusual Vibration	✓				
Unusual Temperature	✓				
Leaks in Pump or Piping	✓				
Pressure Gauge Readings	✓				
Visual Inspection of Equipment General Condition	✓				
Anytime a pump is opened, inspect the running clearance and restore them to original specifications if the running clearances have doubled.	✓•				
Anytime a pump is opened, inspect the impeller for corrosion or excessive wear.	✓•				
Mechanical Seal (should be no leakage)	✓				
Drain Line are Working Properly	✓				
Operate the Pump		✓			
Perform a comparative field test (flow, pressures, and power) with calibrated instruments. Restore internal running clearances if results are unsatisfactory (install new wear rings)					✓•
Perform a comparative vibration test					✓
Inspect Sleeve. Replace if Worn					✓•

Figure 1 - General Pump Inspection and Maintenance Schedule

1750 RPM Centrifugal Pumps

TROUBLESHOOTING

Problem	Possible Cause(s)
No Water Delivered	<ol style="list-style-type: none"> 1 Pump not primed - indicated by no pressure on discharge 2 Speed too low - indicated by low pressure on discharge 3 Valve closed - indicated by high discharge head 4 Impeller completely plugged up - indicated by low discharge pressure
Abnormally Small Quantities Delivered	<ol style="list-style-type: none"> 1 Air leaks in suction pipe or stuffing boxes 2 Speed too low 3 Discharge head higher than anticipated 4 Impeller partially plugged up 5 Obstruction in suction line 6 Mechanical defects: impeller damaged, casing or seal defective
Insufficient Pressure	<p>Speed too low. Might be caused by low voltage or current characteristics different from nameplate reading on the motor</p> <ol style="list-style-type: none"> 1 2 Air in water will cause the pump to make a cracking noise 3 Mechanical defects: worn casing rings, impeller damaged, defective casing or seal
Intermittent Operation	<ol style="list-style-type: none"> 1 Leaky suction line 2 Water seal plugged (hence, a leaky stuffing box) 3 Suction lift too high 4 Air, gas or vapor in liquid
Pump Overloads Driver	<ol style="list-style-type: none"> 1 Speed too high Head lower than rated, hence, pumping too much water (This is valid for low specific speed pumps) 2 Mechanical defects: stuffing boxes too tight, shaft bent, rotating element binds 3 Rubbing due to foreign matter in the pump between the case ring and the impeller 4
Pump Vibrates	<ol style="list-style-type: none"> 1 Misalignment 2 Foundation not sufficiently rigid 3 Impeller partially clogged Mechanical defects: bent shaft, rotating element binds, bearings worn, coupling defective. 4 5 Suction and discharge pipes not anchored 6 Pump cavitating from too high suction lift 7 Air entrainment in the pump suction due to low submergence

For Repair Parts contact dealer where pump was purchased.

Please provide following information:

- Model Number
- Serial Number (if any)
- Part/Kit Description and Number

NOTE: Parts are available only in kits listed, parts are not available individually.

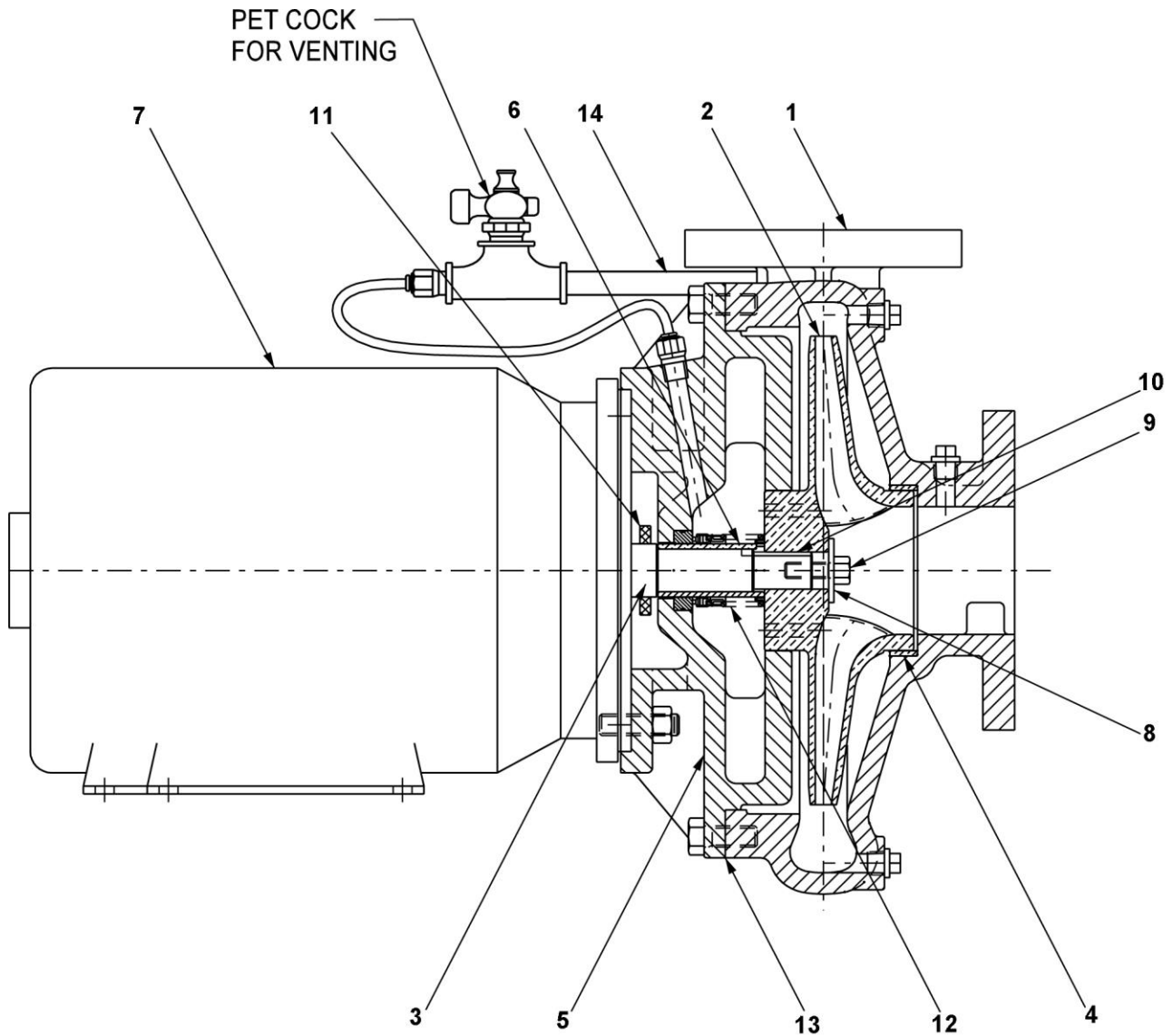

Figure 2 – Repair Parts Illustration

Repair Parts List

Ref.		Part Number for Models:						
No.	Description	420A-95	427A-95	427B-95	428A-95	428B-95	430A-95	Qty
1	Casing Kit (includes Ref. No. 4)	420A-001-95	427A-001-95	427A-001-95	428A-001-95	428A-001-95	430A-001-95	1
2	Impeller Kit (includes Ref. Nos. 8, 9, and 10)	420A-010-97	427A-010-97	427B-010-97	428A-010-97	428B-010-97	430A-010-97	1
3	Motor Shaft (for service reference only)	see Ref.7	see Ref.7	see Ref.7	see Ref.7	see Ref.7	see Ref.7	N/A
4	Casing Ring	Incl. w/Ref 1	Incl. w/Ref 1	Incl. w/Ref 1	Incl. w/Ref 1	Incl. w/Ref 1	Incl. w/Ref 1	N/A
5	Volute Cover Kit	420A-030-95	427A-030-95	427B-030-95	428A-030-95	428B-030-95	430A-030-95	1
6	Shaft Sleeve	420A-140-90	427A-140-90	427B-140-90	428A-140-90	428B-140-90	430A-140-90	1
7	Motor	1626-370-00	1626-371-00	1626-372-00	1626-371-00	1626-372-00	1626-373-00	1
8	Impeller Washer	Incl. w/Ref 2	Incl. w/Ref 2	Incl. w/Ref 2	Incl. w/Ref 2	Incl. w/Ref 2	Incl. w/Ref 2	1
9	Impeller Screw	Incl. w/Ref 2	Incl. w/Ref 2	Incl. w/Ref 2	Incl. w/Ref 2	Incl. w/Ref 2	Incl. w/Ref 2	N/A
10	Impeller Key	Incl. w/Ref 2	Incl. w/Ref 2	Incl. w/Ref 2	Incl. w/Ref 2	Incl. w/Ref 2	Incl. w/Ref 2	N/A
11	Deflector Kit	Incl. w/Ref 12	Incl. w/Ref 12	Incl. w/Ref 12	Incl. w/Ref 12	Incl. w/Ref 12	Incl. w/Ref 12	N/A
12	Seal & Deflector Kit	420A-160-90	427A-160-90	427B-160-90	428A-160-90	428B-160-90	430A-160-90	1
13	Gasket Kit	420A-300-90	427A-300-90	427B-300-90	428A-300-90	428B-300-90	430A-300-90	1
14	Vent & Pet Cock Kit (optional)	420A-170-90	420A-170-90	420A-170-90	420A-170-90	420A-170-90	420A-170-90	1



American Machine & Tool Co., Inc. of PA
(herein "AMT")
400 Spring Street
Royersford, PA 19468
Phone: (610) 948-3800
Fax: (610) 948-5300
www.amtpump.com

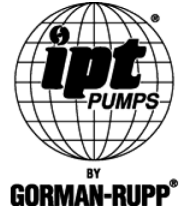

General Information

SALES POLICY: AMT products are sold through our established Distributors. We do not sell direct to the consumer or organization not entitled to trade recognition. Therefore, possession of our catalogs and/or price list(s) does not infer an offer to sell.

MINIMUM ORDER: We appreciate your order, however, all orders are subject to a minimum \$35.00 net invoice charge (excluding freight). This applies to all pump and parts purchase orders.

PRICES: Prices are subject to change without notice. All orders accepted are subject to prices in effect at time of shipment.

PAYMENT TERMS: Terms, upon establishment of credit, are Net 30 days. Past due accounts may be subject to a service charge of 1.5% per month. Domestic or assignable letter of credit is required for all export trade.

PAST DUE ACCOUNTS: AMT reserves the right to withhold open account shipments on any past due account. Invoices are considered past due after thirty (30) days. In the interest of sound business, all orders are subject to approval of the Credit Department.

SHIPPING INSTRUCTIONS: All shipments will be made F.O.B. the factory. Where instructions for shipment do not appear on the order, the shipment will be made according to our best judgment. Full risk of loss (including transportation delays and losses) shall pass to the customer upon delivery of the products to the carrier at the F.O.B. point. When loss or delay occurs, primary responsibility for tracing rests with the customer. When there is LOSS or APPARENT VISIBLE DAMAGE to a shipment, when tendered for delivery, *DO NOT* give the carrier a clear receipt. Note such damage on the carrier's delivery receipt and *HAVE THE DRIVER SIGN THE RECEIPT.*

PRODUCT REVISIONS: AMT reserves the right to discontinue, change or improve its products or any portions thereof without being obligated to provide such a change or improvement for units sold and/or shipped prior to such a change or improvement.

LEAD TIME: Products designated "Quick Ship Product", also referred to as "QSP" will normally be shipped within 24 hours of receipt of a non-cancellable purchase order. Only limited quantities of "QSP" pumps are available.

STANDARD LEAD TIME: Lead time is two weeks for all non "QSP" product. AMT reserves the right to revise lead times as required due to availability of materials and all other causes beyond our control.

VIP SHIPMENT: Select AMT and IPT branded pumps are available for next day shipment for non-QSP (Quick Ship Products) items and subjected to a specific model surcharge per unit noted in the respective price book. Requires calling for availability, confirmation and a non-cancellable purchase order or credit card payment prior to shipment. The expedited shipping charges are an additional cost added separately from the VIP charges per item. AMT reserves the right to revise lead times as required due to availability of materials and all other causes beyond our control. QSP quantities are limited as determined by AMT.

ALL purchase orders must be submitted via hard copy sent to AMT customer service department by fax, EDI or e-mail.

RETURN GOODS POLICY: Goods shall not be returned without a return goods authorization number (RGA) issued by AMT customer service. The RGA number must be listed on the packing list. Only current model and part numbers with a valid date code may be returned (within one year from date of purchase). **A 20% restocking and packaging charge will apply to all returns. All shipping charges must be pre-paid. No exceptions.**

ORDER CHANGES BY CUSTOMER: Orders in process may not be changed except with written consent and may be subject to special charges.

12 Month Limited Warranty

EXTENT AND DURATION OF LIMITED WARRANTY

Coverage: American Machine & Tool Company (herein "AMT") or IPT Pumps by Gorman-Rupp (herein "IPT") or Gorman-Rupp Industries Division of The Gorman-Rupp Company, Patterson, or the Gorman-Rupp Company (herein referred to as "G-R Unit") each individually warrants that its products and parts shall be free from defects in material and workmanship for twelve (12) months from the date of purchase by the original end user when installation is made and maintenance is performed in accordance with G-R Unit's recommendations. Wear and tear resulting from use and items normally consumed in use are not covered.

EXCEPTIONS

(A) This Limited Warranty shall not apply to mechanical seals in AMT or IPT pumps and the following products and parts: engines, motors, trade accessories and all other products, components, parts and materials not manufactured by the G-R Units. These items may, however, be covered by the warranties of their respective manufacturers. (B) This warranty does not extend to or apply to any unit which has been repaired or altered at any place other than by a G-R Unit, or by persons not expressly approved by a G-R Unit to make repairs or alterations, nor to any unit the serial number, model number or identification of which has been removed, defaced or altered. (C) This warranty does not extend to any product manufactured by a G-R Unit, which has been subjected to mis-use, neglect, accident, improper installation, or use in violation of instructions furnished by a G-R Unit. (D) Pump Kits: This warranty does not extend to any product sold by a G-R Unit unassembled as a Pump Kit. Pump Kits are warranted against defects in material and workmanship for 60 days from the date of shipment from a G-R Unit. Any Pump Kit parts deemed defective by a G-R Unit will be replaced free of charge within 60 days of shipment. Pump Kits are not returnable for credit.

LIMITATIONS

THE G-R UNITS' SOLE AND EXCLUSIVE WARRANTY WITH RESPECT TO THEIR PRODUCTS AND PARTS IS THIS LIMITED WARRANTY. THIS LIMITED WARRANTY IS IN LIEU OF ALL OTHER EXPRESS AND/OR IMPLIED WARRANTIES, INCLUDING IMPLIED WARRANTIES OF MERCHANTABILITY AND FITNESS FOR PARTICULAR PURPOSE.

EXCLUSIVE REMEDY AND DAMAGES

The sole and exclusive remedy for breach of this Warranty by a G-R Unit and the entire extent of its liability for such breach or for damages arising from the use of the products and parts covered under this Limited Warranty, shall be as follows:

- Repair or Replacement:** If inspection shows that any G-R Unit product or part covered under this Limited Warranty is defective in materials or workmanship, the G-R Unit shall repair or replace the defective or non-conforming product or part without charge, whichever the G-R Unit chooses. You must have properly maintained and used the product or part claimed to be defective in accordance with the maintenance schedule or manual, which comes with the product. No allowance will be made for labor, installation, removal, transportation or other charges incurred by you in connection with such repair or replacement.
- To obtain the above remedy:
 - Immediately notify the G-R Unit upon discovery of the claimed defect in materials or workmanship and provide the serial number or date code of the product and/or part(s) or provide the G-R Unit with the invoice or bill of sale referencing the product by no later than the expiration date of the warranty period.
 - The G-R Unit will advise whether inspection will be necessary and how whether repair or replacement will be made. If inspection by the G-R Unit is necessary, the pump or defective part must be sent freight pre-paid to the G-R Unit. Return shipment will be F.O.B. the G-R Unit's plant.
 - Return Goods Authorization Requirement:** No product will be accepted for return or replacement without the prior written authorization of the G-R Unit. Upon such authorization, and in accordance with instructions from the G-R Unit, the product will be returned to the G-R Unit, shipping charges prepaid by the Buyer.
- Damages:** The G-R Unit's liability for damages for breach of this Limited Warranty shall not exceed the amount of the purchase price of the product or part(s) in respect to which Such damages are claimed. **IN NO EVENT SHALL THE G-R UNITS BE LIABLE FOR INCIDENTAL, CONSEQUENTIAL OR SPECIAL DAMAGES FOR BREACH OF THIS LIMITED WARRANTY.**

Some states do not allow the exclusion or limitation of incidental or consequential damages, so the above limitation or exclusion may not apply to you. This Limited Warranty gives you specific legal rights, and you may also have other rights, which vary from state to state.



A Gorman-Rupp Company



BY

GORMAN-RUPP®

www.amtpump.com